

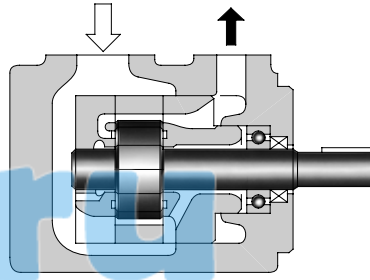

"PV2R" SERIES
Single Pump-Type PV2R1 / PV2R2 / PV2R3 / PV2R4
 Model Number Designation / Pipe Flange Kits

VANE PUMPS

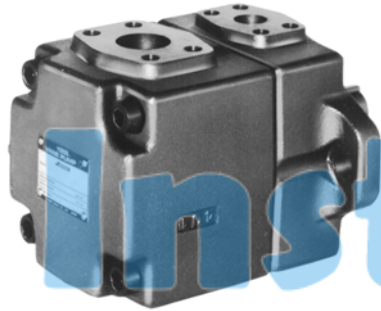

Graphic Symbol

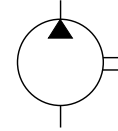

■ Model Number Designation

F-	PV2R1	-6	-L	-R	A	A	-40	-*	
Special Seals	Series Number	Nominal Displacement cm ³ /rev	Type of Mounting	Shaft Rotation	Discharge Port Position	Suction Port Position	Design Number	Design Standards	
F: For phosphate ester type fluids (Omit if not required)	PV2R1	6, 8 10, 12 14, 17 19, 23 25, 31	L: Foot Mounting	(Viewed from Shaft End)			A: Upwards (Normal)	40	Refer to ★ 2
	PV2R2	41, 47 53, 59 65		R: Clockwise ★1 (Normal)	A: Upwards (Normal)	40			
	PV2R3	76, 94 116	F: Flange Mounting			30			
	PV2R4	136, 153 184, 200 237		30					

★1. Available to supply pump with anti-clockwise rotation. Consult Yuken for details.
 ★2. Design Standards: None.....Japanese Standard "JIS"
 80.....European Design Standard
 90.....N. American Design Standard

■ Pipe Flange Kits

Pipe flange kits are available. When ordering, specify the kit number from the table below.

Pump Model Numbers	Name of Port	Pipe Flange Kit Numbers						
		Threaded Connection			Socket Welding*		Butt Welding	
		Japanese Standard "JIS"	European Design Standard	N. American Design Standard	Japanese Standard "JIS" European Design Standard	N. American Design Standard	Japanese Standard "JIS" European Design Standard	N. American Design Standard
PV2R1	Suction	F5-08-A-10	F5-08-A-1080	F5-08-A-1090	F5-08-B-10	F5-08-B-1090	F5-08-C-10	F5-08-C-1090
	Discharge	F5-04-A-10	F5-04-A-1080	F5-04-A-1090	F5-04-B-10	F5-04-B-1090	F5-04-C-10	F5-04-C-1090
PV2R2	Suction	F5-10-A-10	F5-10-A-1080	F5-10-A-1090	F5-10-B-10	F5-10-B-1090	F5-10-C-10	F5-10-C-1090
	Discharge	F5-06-A-10	F5-06-A-1080	F5-06-A-1090	F5-06-B-10	F5-06-B-1090	F5-06-C-10	F5-06-C-1090
PV2R3	Suction	F5-16-A-10	F5-16-A-1080	F5-16-A-1090	F5-16-B-10	F5-16-B-1090	F5-16-C-10	F5-16-C-1090
	Discharge	F5-10-A-10	F5-10-A-1080	F5-10-A-1090	F5-10-B-10	F5-10-B-1090	F5-10-C-10	F5-10-C-1090
PV2R4	Suction	F5-24-A-10	—	—	F5-24-B-10	F5-24-B-1090	F5-24-C-10	F5-24-C-1090
	Discharge	F5-12-A-10	F5-12-A-1080	F5-12-A-1090	F5-12-B-10	F5-12-B-1090	F5-12-C-10	F5-12-C-1090

★In case of using socket welding flanges, there is a case where the operating pressure should be set lower than the normal because of strength of the flanges. Therefore, please pay cautious attention to the operating pressure when the socket welding flanges are used.

Notes: Special seals (Viton seals) are required when phosphate ester type fluids are used. (Prefix "F-" to the pipe flange kit number when ordering.)

●Details of the pipe flange kits are given in the Catalogue No. Pub. EC-3001.



"PV2R" Series
Single Pump - Type PV2R1/PV2R2/PV2R3/PV2R4

VANE PUMPS

Specifications

B

Specifications

Model Numbers	Geometric Displacement cm ³ /rev (cu.in./rev)	Max. Operating Pressure MPa (PSI)						Output Flow & Input Power	Shaft Speed Range r/min	
		Petroleum Base Oils		Water Containing Fluids			Synthetic Fluids		Max.	Min.
		Anti-Wear Type	R & O Type	Anti-Wear ^{★1} Type Water Glycols	Water Glycols	Water in Oil Emulsions	Phosphate Esters			
PV2R1-6	5.8 (.354)	21 ^{★6} (3050)	16 (2320)	16 (2320)	7 (1020)	7 (1020)	16 (2320)	Refer to Pages 11-13	1800 (1200) ^{★4}	750 ^{★5}
PV2R1-8	8.0 (.488)									
PV2R1-10	9.4 (.574)									
PV2R1-12	12.2 (.744)									
PV2R1-14	13.7 (.836)									
PV2R1-17	16.6 (1.013)									
PV2R1-19	18.6 (1.135)									
PV2R1-25	25.3 (1.544)									
PV2R1-31	31.0 (1.892)	16 (2320)								
PV2R2-41	41.3 (2.52)	21 (3050)	14 (2030)	16 (2320)	7 (1020)	7 (1020)	14 (2030)	Refer to Pages 13&14	1800 (1200) ^{★4}	600 ^{★5}
PV2R2-47	47.2 (2.88)									
PV2R2-53	52.5 (3.20)									
PV2R2-59	58.2 (3.55)									
PV2R2-65	64.7 (3.95)									
PV2R3-76	76.4 (4.66)	21 (3050)	14 (2030)	16 (2320)	7 (1020)	7 (1020)	14 (2030)	Refer to Page 15	1800 (1200) ^{★4}	600
PV2R3-94	93.6 (5.71)								1800 ^{★2} (1200) ^{★4}	
PV2R3-116	115.6 (7.05)	16 (2320)								
PV2R4-136	136 (8.30)	17.5 (2540)	14 (2030)	16 (2320)	7 (1020)	7 (1020)	14 (2030)	Refer to Pages 15&16	1800 (1200) ^{★4}	600
PV2R4-153	153 (9.34)									
PV2R4-184	184 (11.23)									
PV2R4-200	201 (12.26)									
PV2R4-237	237 (14.46)								1800 ^{★3} (1200) ^{★4}	

- ★1. For the brands of anti-wear water-glycols , see the item of "Hydraulic Fluids" on page 3.
- ★2. If PV2R3-116 is used at speed above 1700 r/min, the suction pressure is limited to 0 kPa (0 in. Hg.).
- ★3. If PV2R4-237 is used at speed above 1700 r/min, the suction pressure is limited to -13 kPa (3.94 in. Hg. vacuum).
- ★4. If phosphate ester or water containing fluids are used, the maximum speed is limited to 1200 r/min.
- ★5. For starting at low speed, the maximum viscosity is limited. For details, see the item of "Hydraulic Fluids" on page 3.
- ★6. For pressure above 16 MPa (2320 PSI), raise the speed over 1450 r/min.

● Mass

Model Numbers	Approx. Mass kg (lbs.)	
	Flange Mtg.	Foot Mtg.
PVR2R1	9.0 (19.8)	11.2 (24.7)
PVR2R2	15.5 (34.2)	19.8 (43.7)
PVR2R3	30.9 (68.1)	40.9 (90.2)
PVR2R4	68.5 (151)	93.5 (206)



"PV2R" Series Single Pump - Type "PV2R1"

VANE
PUMPS

Installation Drawing

Flange Mtg.: PV2R1-*F-RAA-40/4090

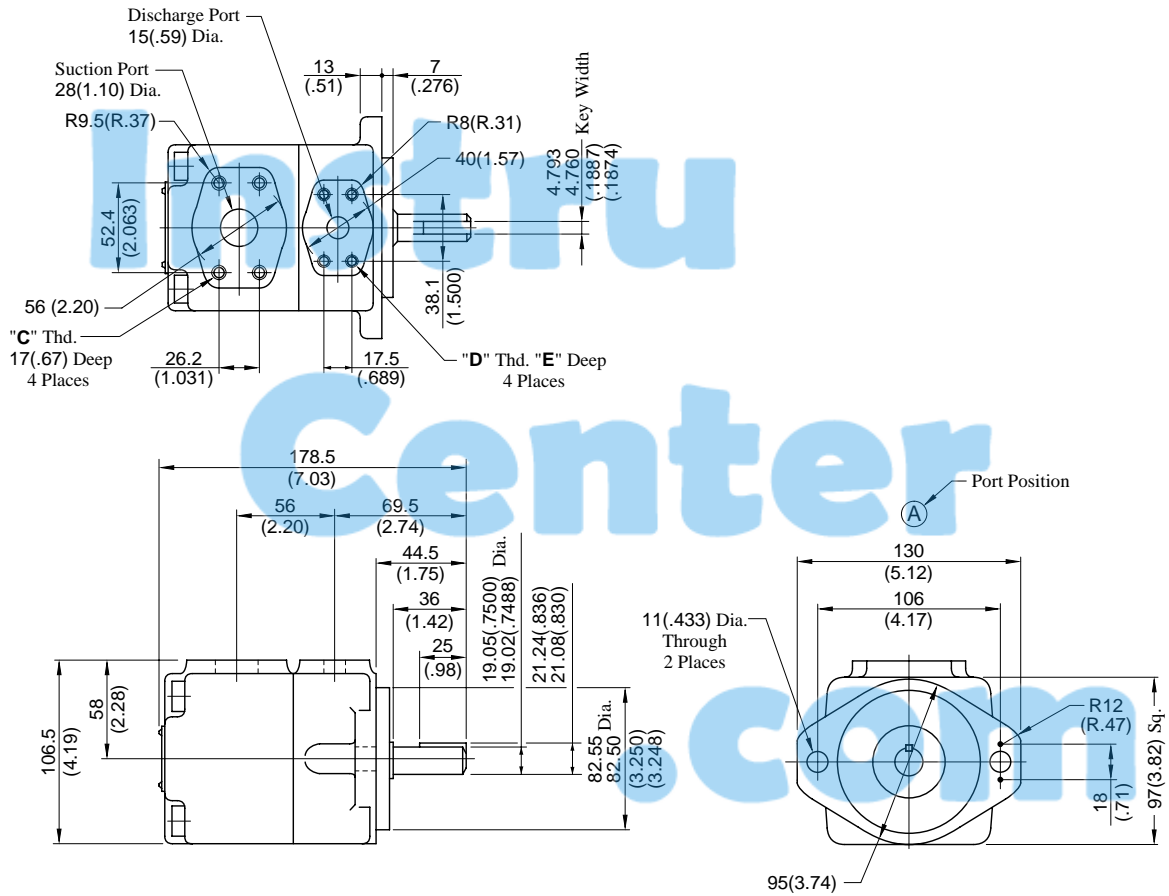

Model Numbers	"C" Thd.	"D" Thd.	E mm (Inches)
PV2R1-*F-RAA-40	M10	M8	14 (.55)
PV2R1-*F-RAA-4090	3/8-16 UNC	5/16-18 UNC	16 (.63)

DIMENSIONS IN
MILLIMETRES (INCHES)

Foot Mtg.: PV2R1-*L-RAA-40/4090

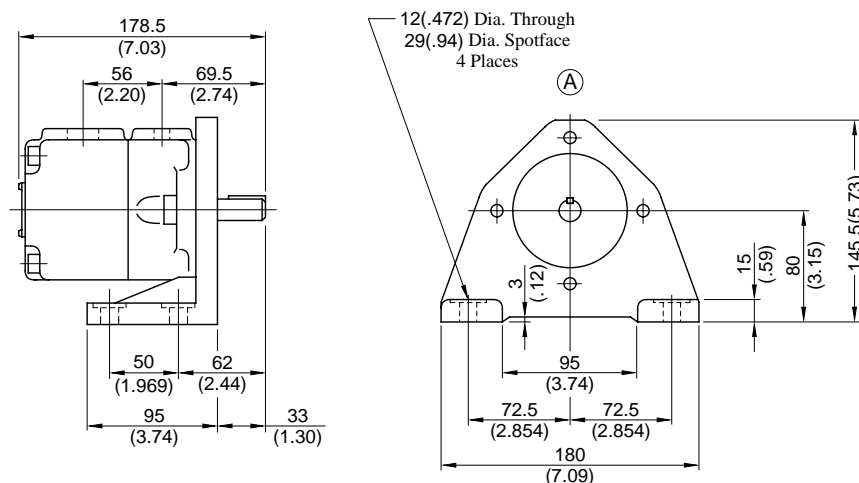

• For other dimensions, refer to "Flange Mtg.".



"PV2R" Series Single Pump - Type "PV2R2"

VANE
PUMPS

Installation Drawing

B

Flange Mtg.: PV2R2-*-F-RAA-40/4090

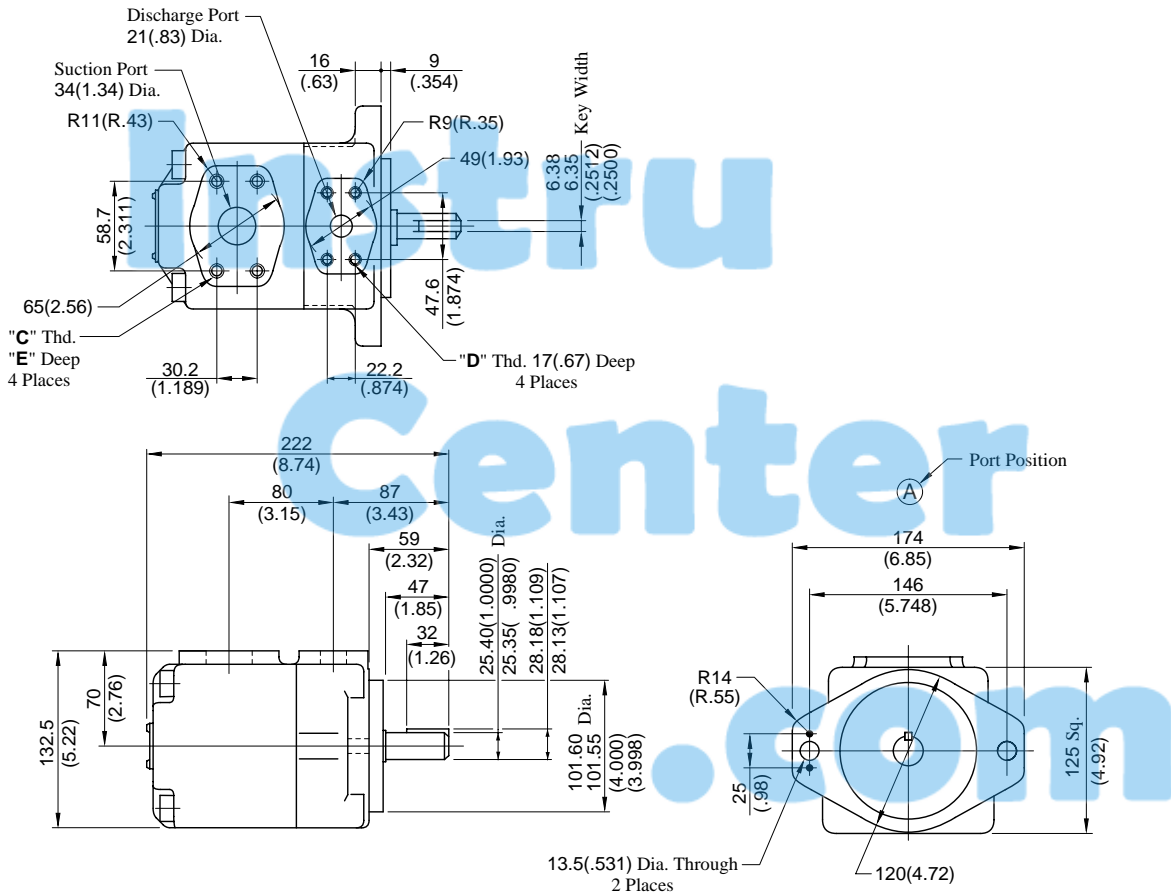

Model Numbers	"C" Thd.	"D" Thd.	E mm (Inches)
PV2R2-*-F-RAA-40	M10	M8	19 (.75)
PV2R2-*-F-RAA-4090	7/16-14 UNC	3/8-16 UNC	20 (.79)

DIMENSIONS IN
MILLIMETRES (INCHES)

Foot Mtg.: PV2R2-*-L-RAA-40/4090

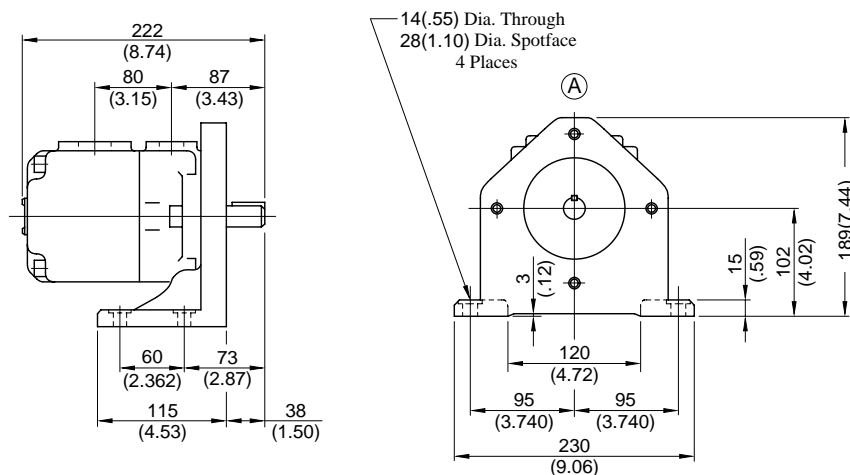

• For other dimensions, refer to "Flange Mtg.".



"PV2R" Series Single Pump - Type "PV2R3"

VANE
PUMPS

Installation Drawing

Flange Mtg.: PV2R3-*-F-RAA-30/3090

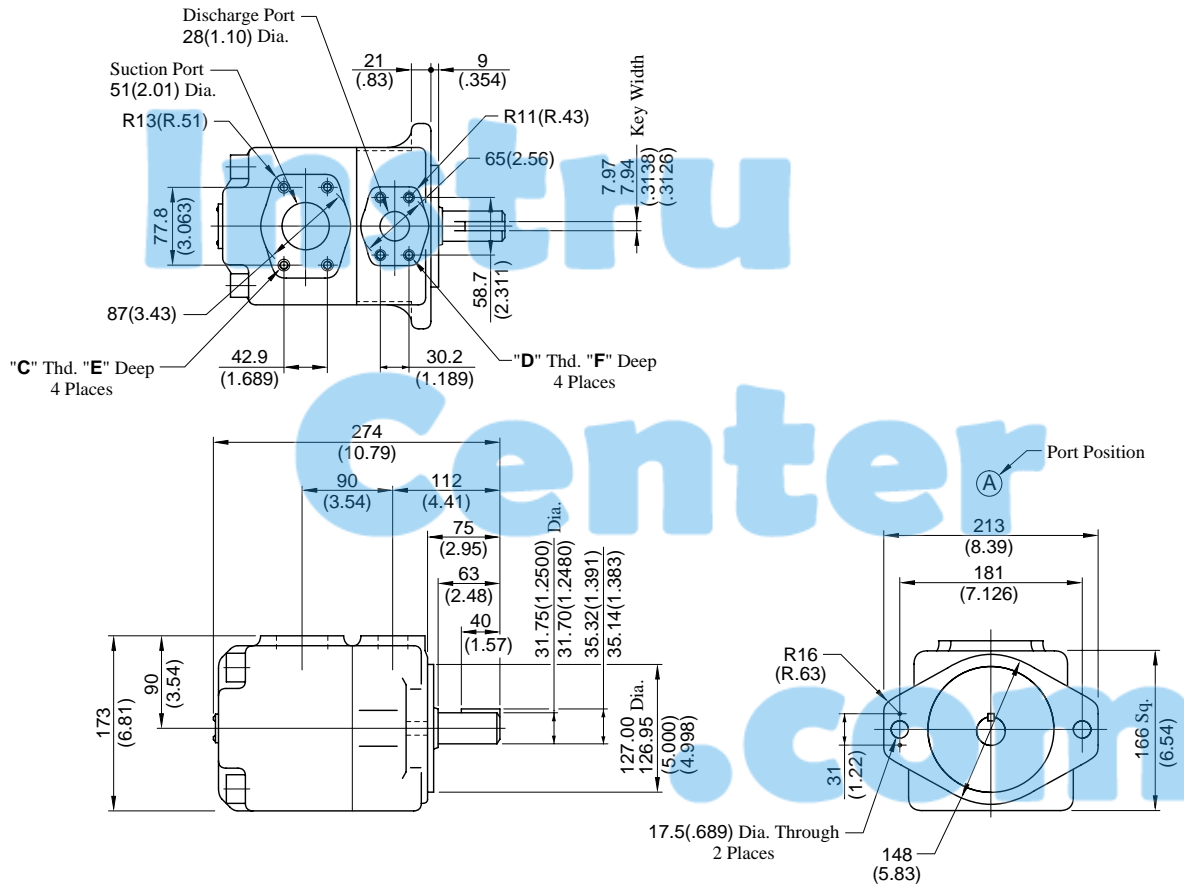

Model Numbers	"C" Thd.	"D" Thd.	Dimensions mm (Inches)	
			E	F
PV2R3-*-F-RAA-30	M12	M10	19 (.75)	19 (.75)
PV2R3-*-F-RAA-3090	1/2-13 UNC	7/16-14 UNC	21 (.83)	20 (.79)

DIMENSIONS IN MILLIMETRES (INCHES)

Foot Mtg.: PV2R3-*-L-RAA-30/3090

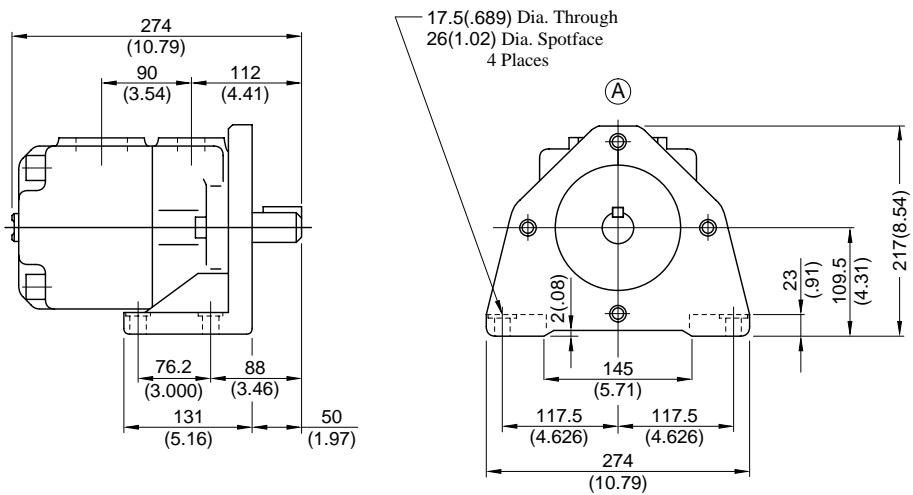

• For other dimensions, refer to "Flange Mtg.".



"PV2R" Series Single Pump - Type "PV2R4"

VANE
PUMPS

Installation Drawing

B

Flange Mtg.: PV2R4-*-F-RAA-30/3090

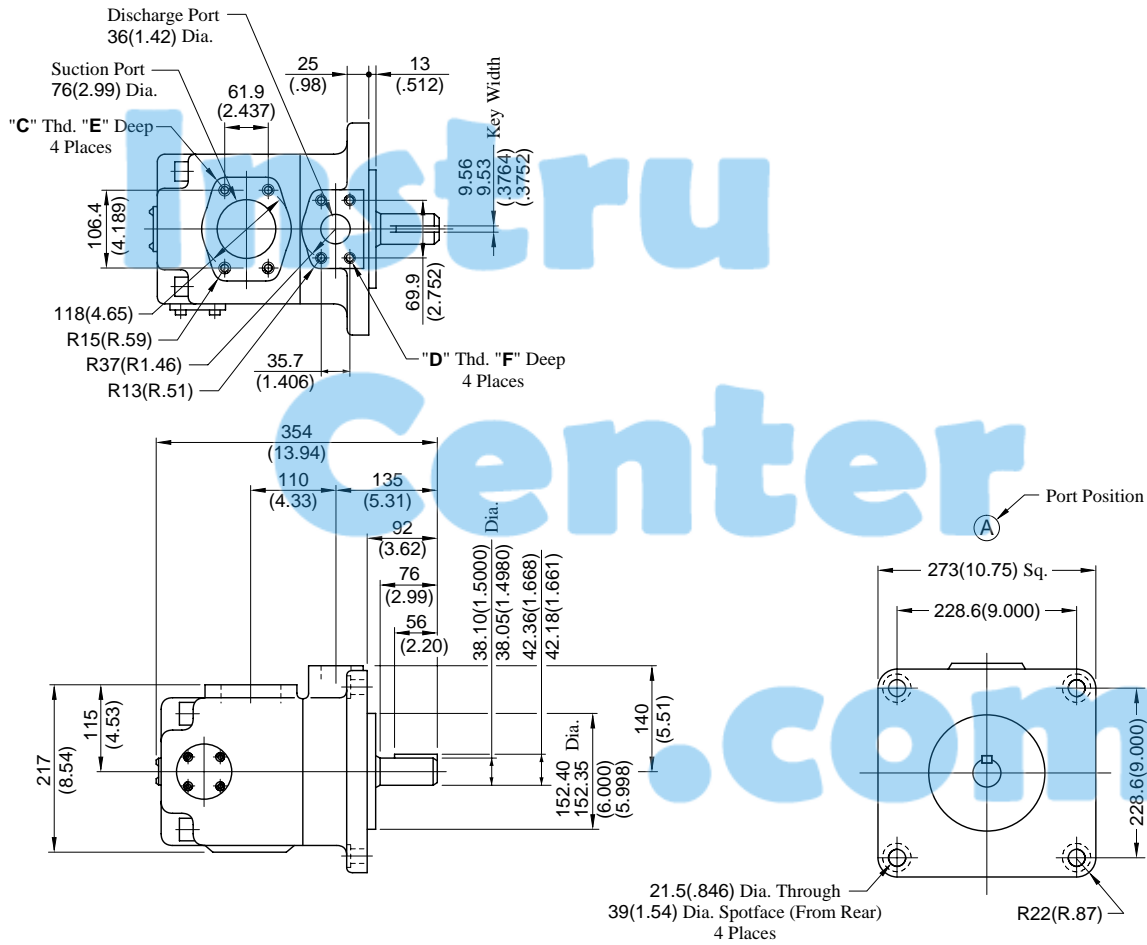

Model Numbers	"C" Thd.	"D" Thd.	Dimensions mm (Inches)	
			E	F
PV2R4-*-F-RAA-30	M16	M12	19 (.75)	19 (.75)
PV2R4-*-F-RAA-3090	1/2-13 UNC	5/8-11 UNC	21 (.83)	21 (.83)

**DIMENSIONS IN
MILLIMETRES (INCHES)**

Foot Mtg.: PV2R4-*-L-RAA-30/3090

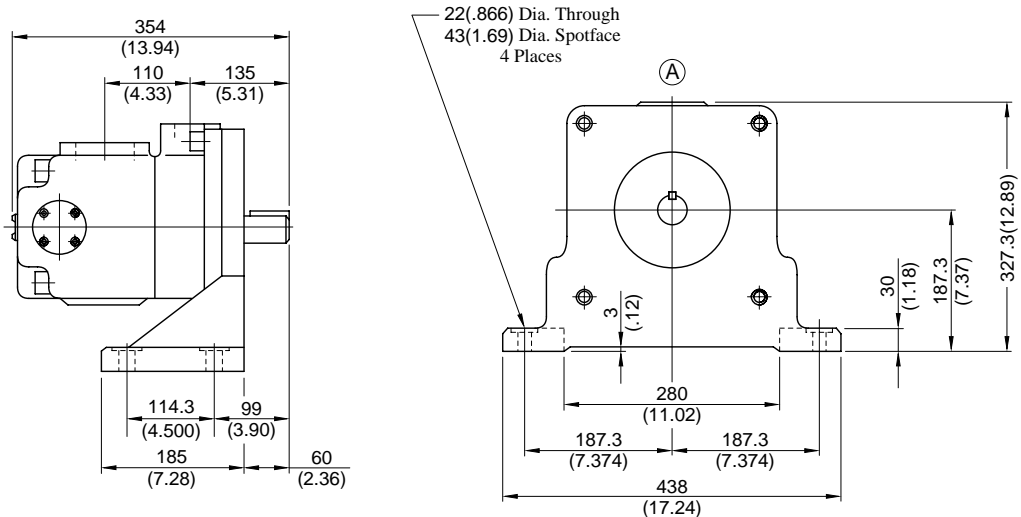

• For other dimensions, refer to "Flange Mtg."



"PV2R" Series
Single Pump-Type PV2R1 / PV2R2 / PV2R3 / PV2R4

VANE PUMPS

Typical Pump Characteristics

■ Noise Level

● Measuring conditions

Fluid viscosity : 20 mm²/s (100 SSU)

Measurement point : One metre (3.3 ft.) horizontally away from pump head cover

Back ground noise : 40 dB (A)

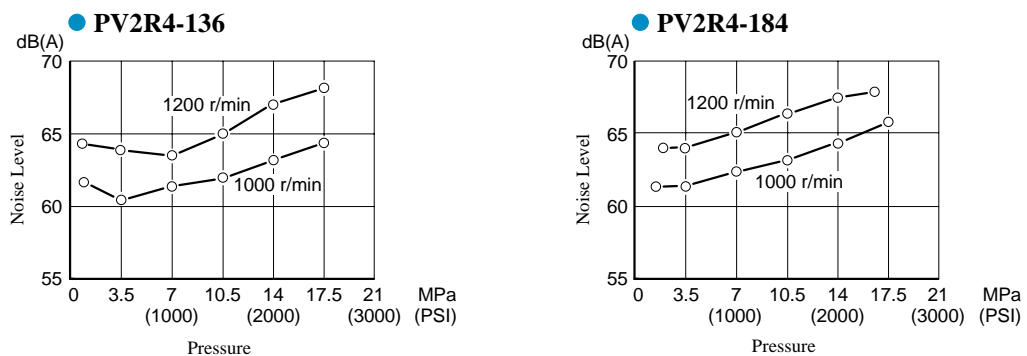
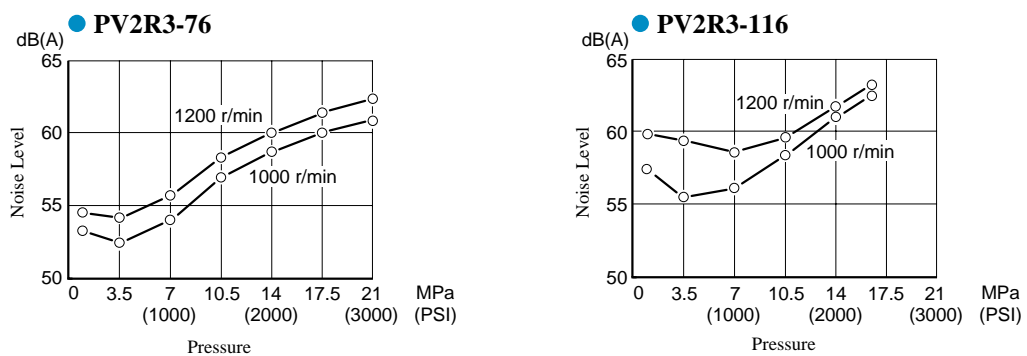
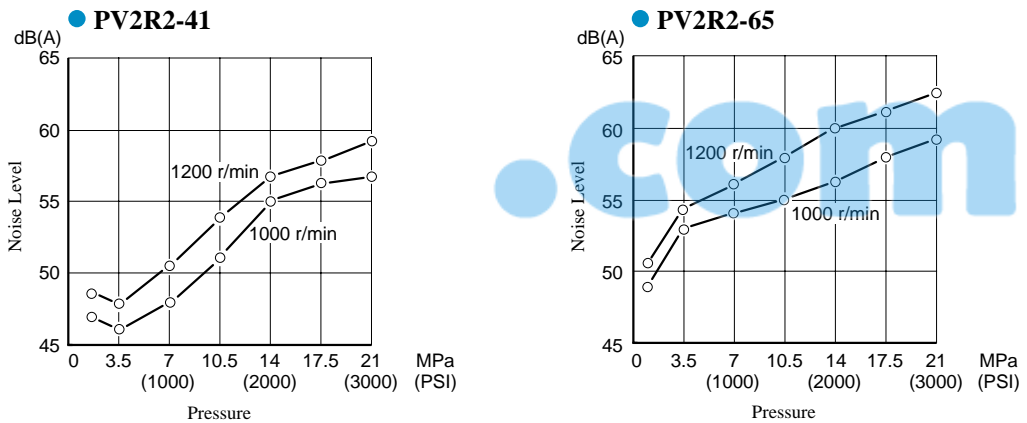
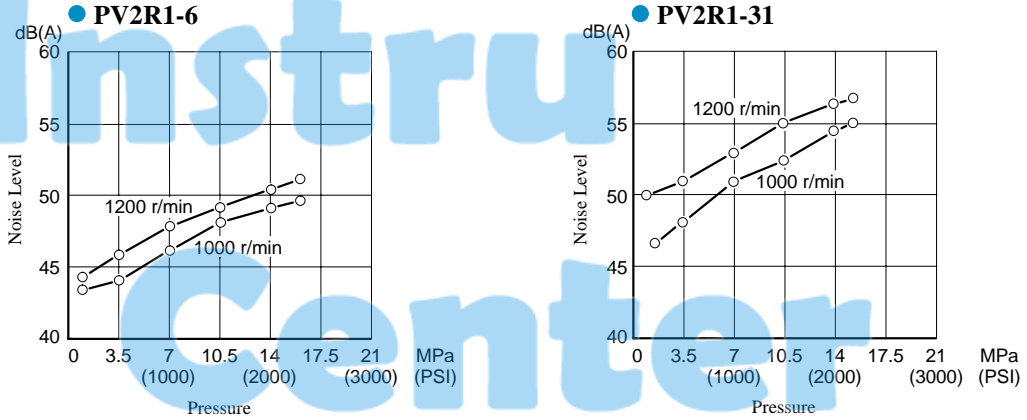



"PV2R" Series Single Pump - Type "PV2R1"

VANE
PUMPS

Typical Pump Characteristics

B

Viscosity 20 mm²/s (100 SSU) [ISO VG32 Oils, 50°C (122°F)]

● PV2R1-6

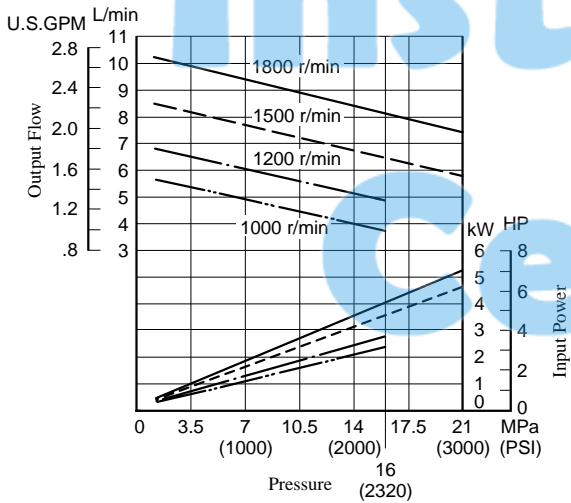

● PV2R1-8

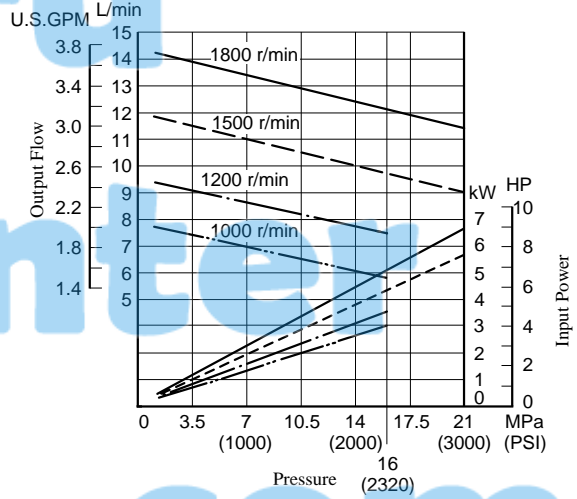

● PV2R1-10

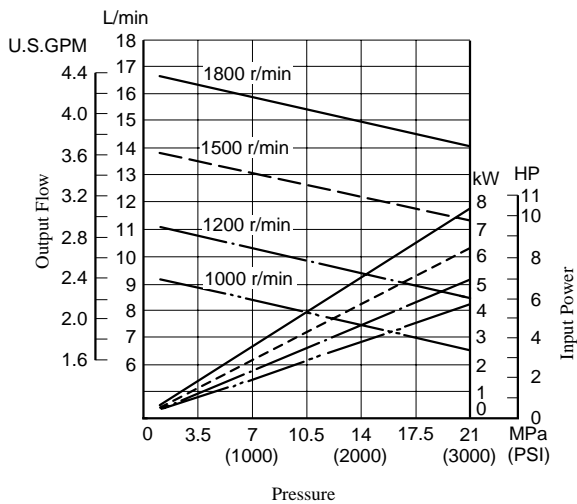

● PV2R1-12

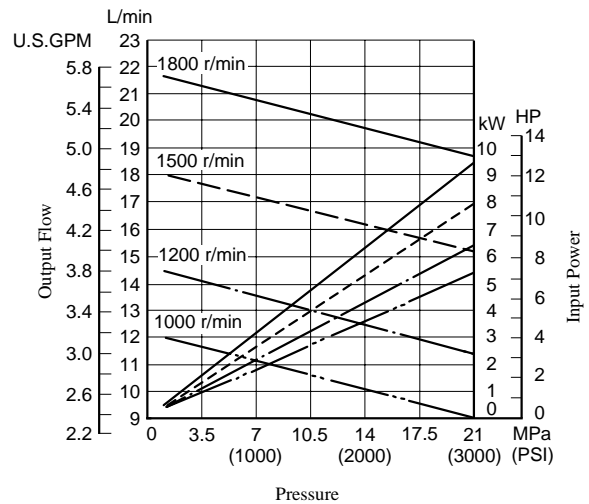



"PV2R" Series
Single Pump-Type "PV2R1"

VANE
PUMPS

Typical Pump Characteristics

Viscosity 20 mm²/s (100 SSU) [ISO VG32 Oils, 50°C (122°F)]

● PV2R1-14

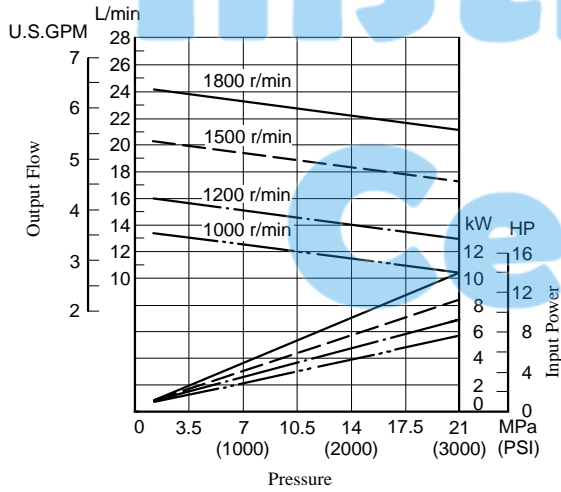

● PV2R1-17

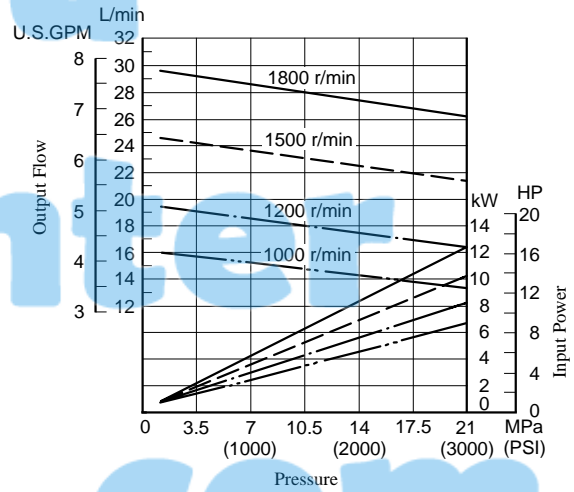

● PV2R1-19

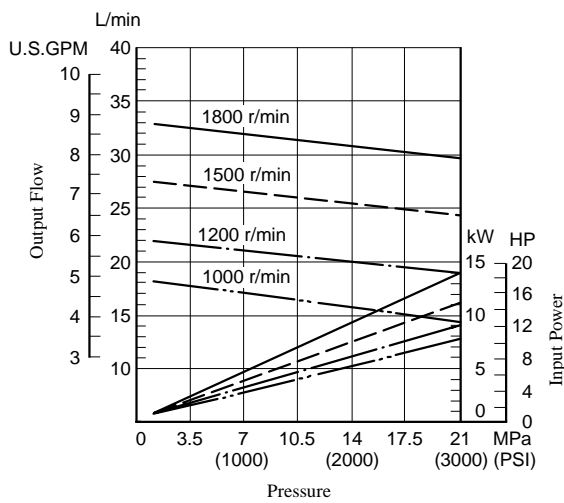

● PV2R1-23

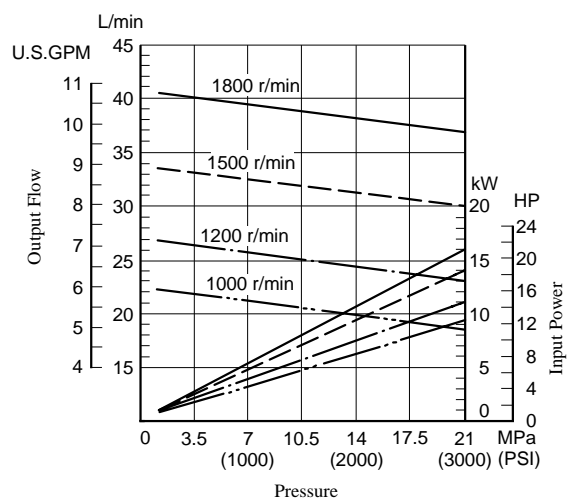



"PV2R" Series
Single Pump - Type "PV2R1 & PV2R2"

VANE PUMPS

Typical Pump Characteristics

B

Viscosity 20 mm²/s (100 SSU) [ISO VG32 Oils, 50°C (122°F)]

● PV2R1-25

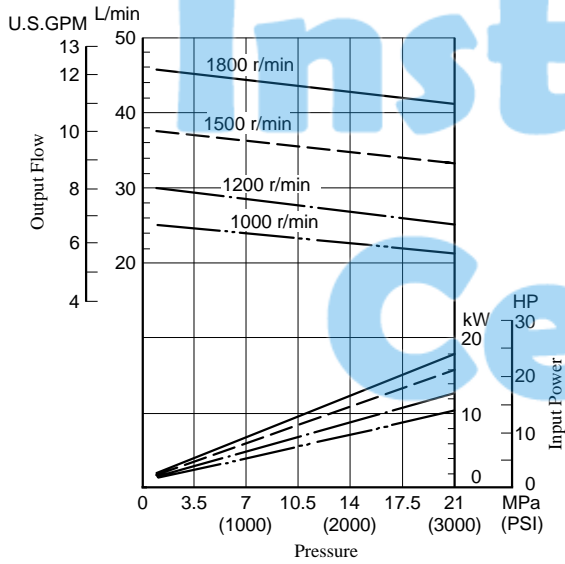

● PV2R1-31

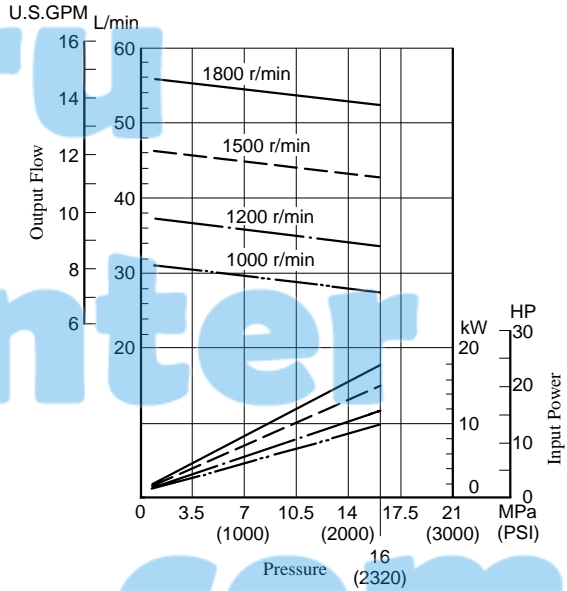

● PV2R2-41

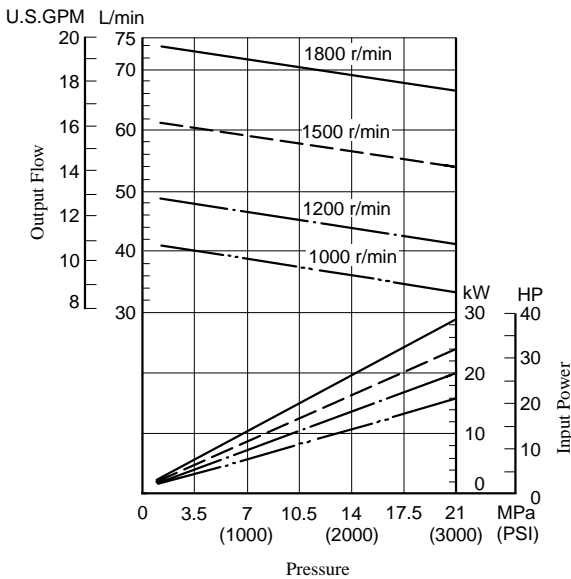

● PV2R2-47

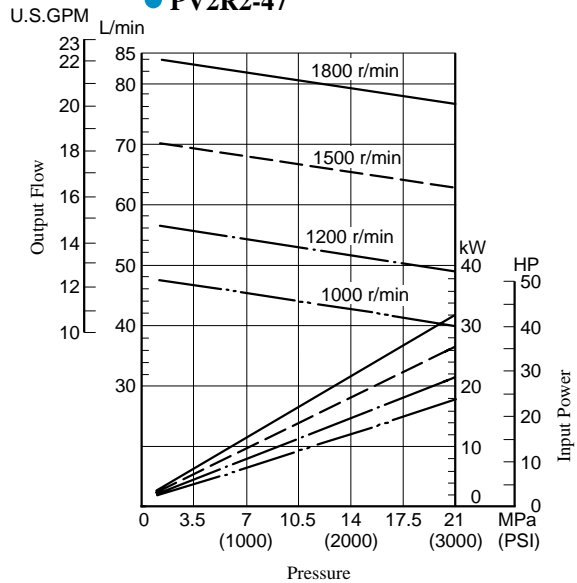



"PV2R" Series
Single Pump-Type "PV2R2"

VANE
PUMPS

Typical Pump Characteristics

Viscosity 20 mm²/s (100 SSU) [ISO VG32 Oils, 50°C (122°F)]

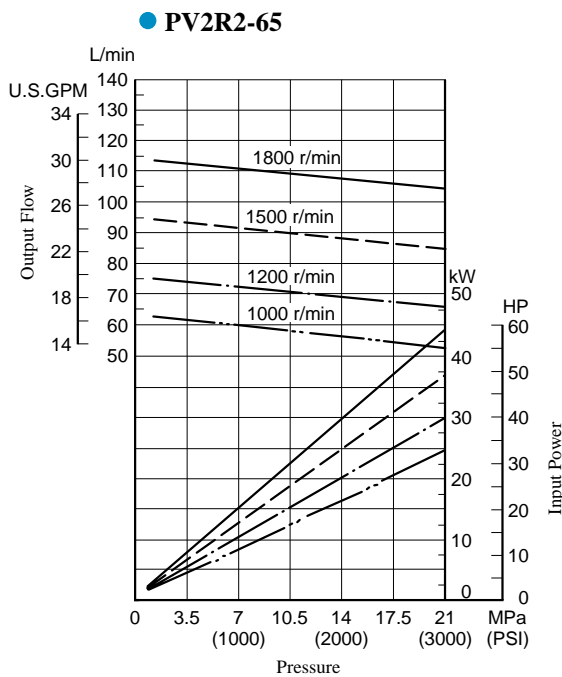
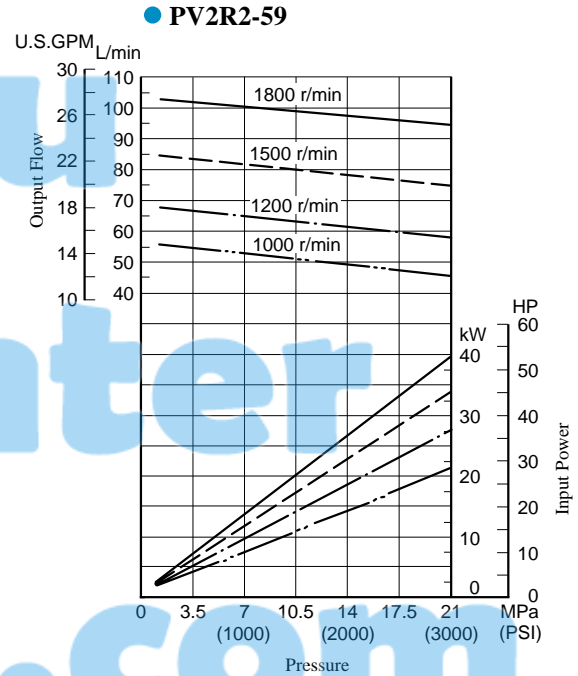
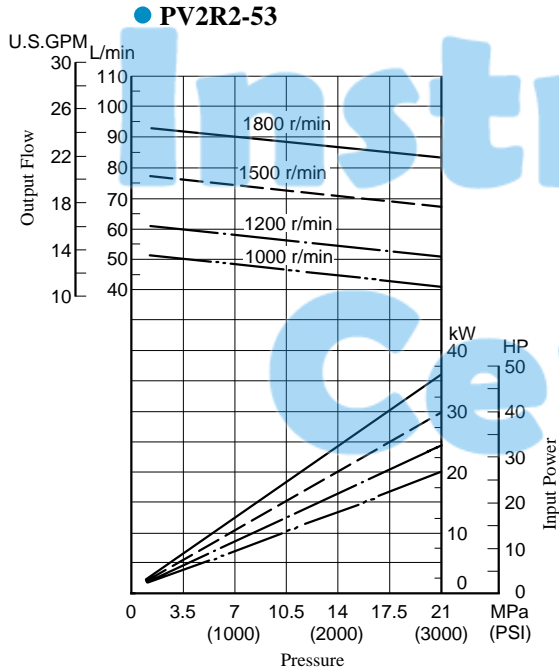



"PV2R" Series
Single Pump - Type "PV2R3 & PV2R4"

VANE PUMPS

Typical Pump Characteristics

B

Viscosity 20 mm²/s (100 SSU) [ISO VG32 Oils, 50°C (122°F)]

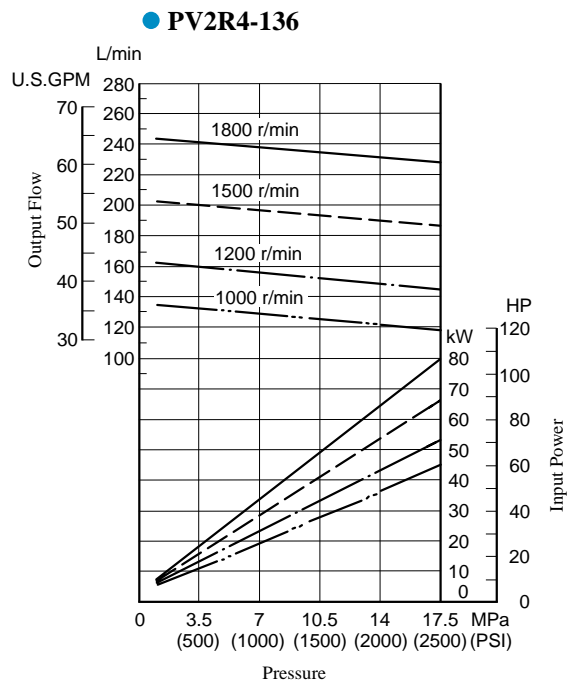
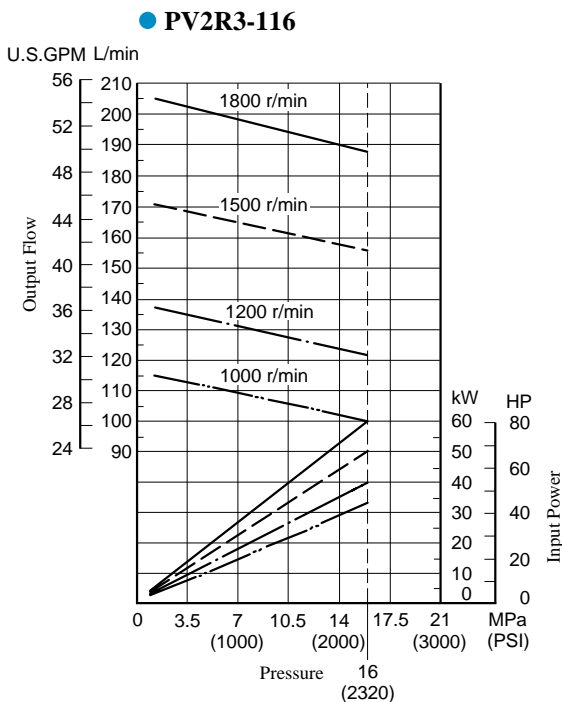
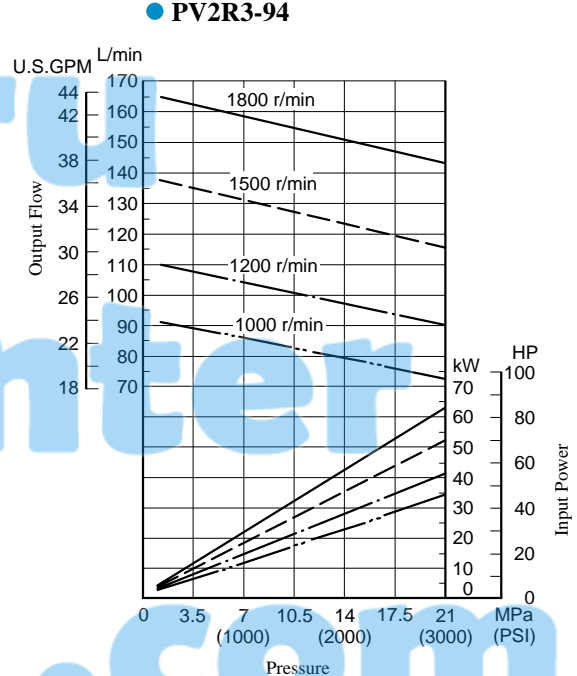
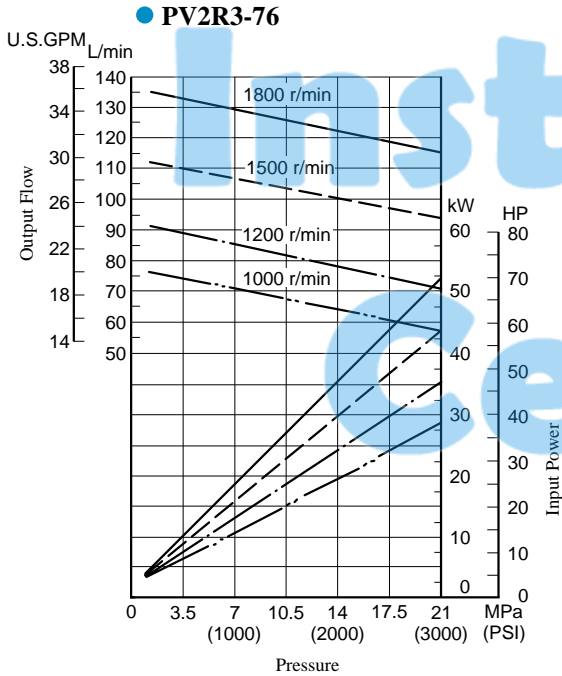



"PV2R" Series
Single Pump-Type "PV2R4"

VANE
PUMPS

Typical Pump Characteristics

Viscosity 20 mm²/s (100 SSU) [ISO VG32 Oils, 50°C (122°F)]

● PV2R4-153

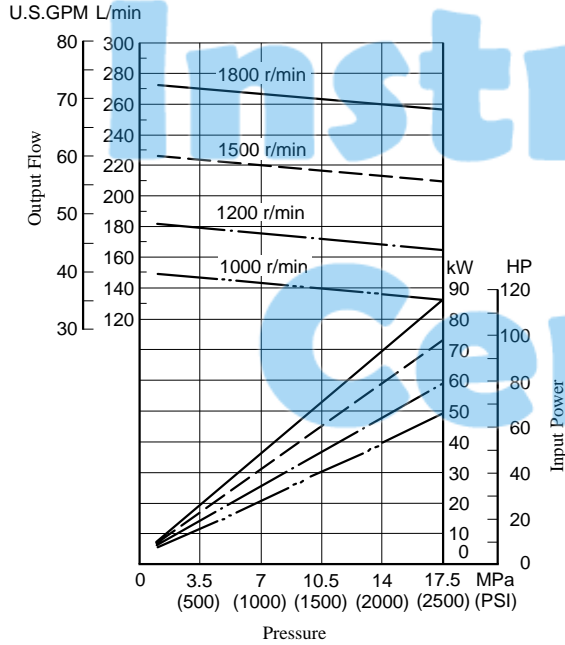

● PV2R4-184

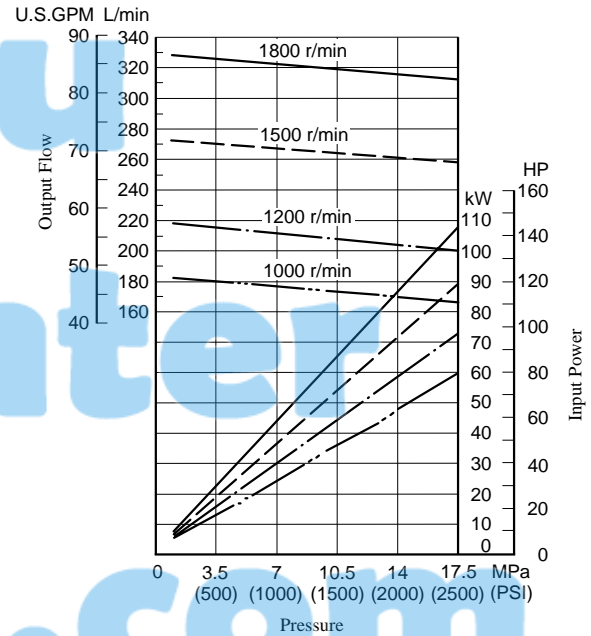

● PV2R4-200

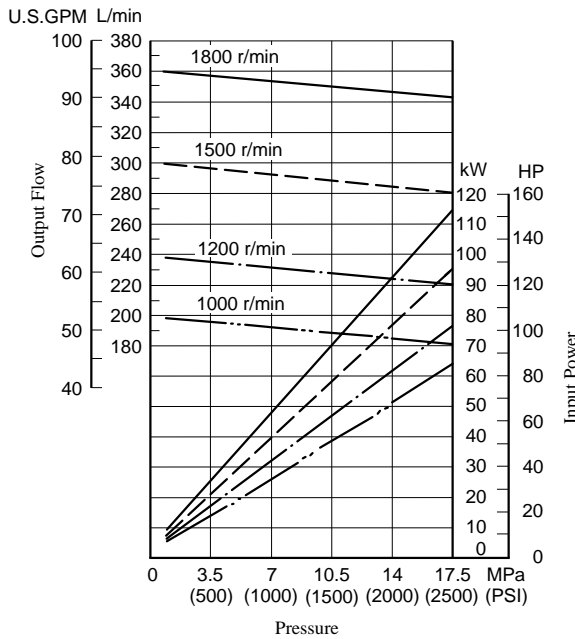

● PV2R4-237

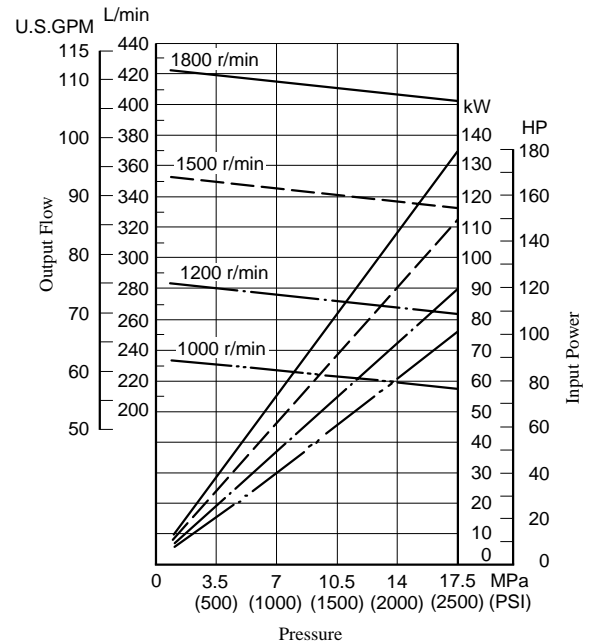



"PV2R" Series Fixed Displacement - Single PV2R1/PV2R2/PV2R3/PV2R4

VANE PUMPS

Spare Parts Lists

B

PV2R1-*-*-RAA-40/4090
PV2R2-*-*-RAA-40/4090
PV2R3-*-*-RAA-30/3090
PV2R4-*-*-RAA-30/3090

⚠ CAUTION

When making replacement of seals, bearings or cartridge kits, please do it carefully after reading through the relevant instructions in the Operator's Manual.

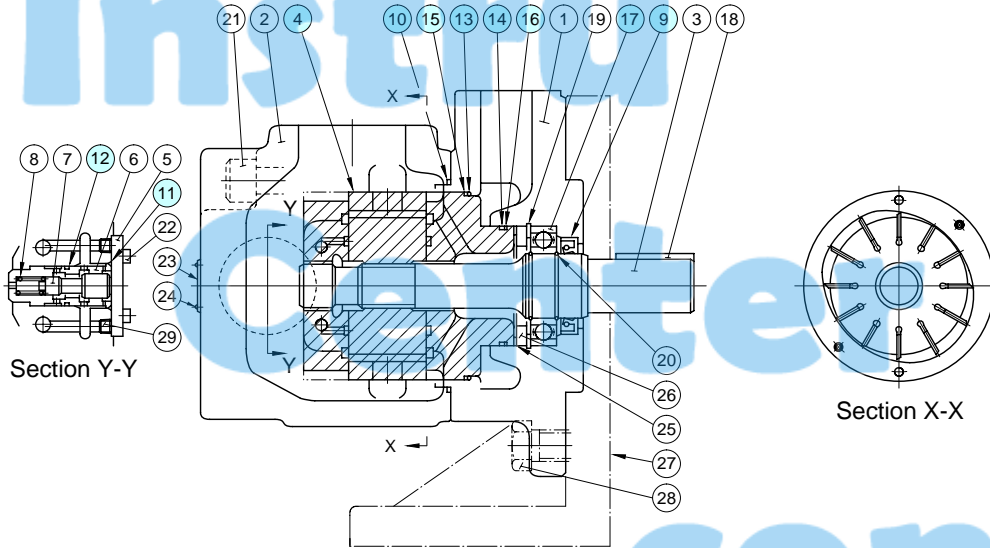

● Cartridge Kits

Model Numbers	④ Cartridge Kit Numbers	Model Numbers	④ Cartridge Kit Numbers
PV2R1-6-*-RAA-40*	CPV2R1-6-R-40	PV2R2-41-*-RAA-40*	CPV2R2-41-R-40
PV2R1-8-*-RAA-40*	CPV2R1-8-R-40	PV2R2-47-*-RAA-40*	CPV2R2-47-R-40
PV2R1-10-*-RAA-40*	CPV2R1-10-R-40	PV2R2-53-*-RAA-40*	CPV2R2-53-R-40
PV2R1-12-*-RAA-40*	CPV2R1-12-R-40	PV2R2-59-*-RAA-40*	CPV2R2-59-R-40
PV2R1-14-*-RAA-40*	CPV2R1-14-R-40	PV2R2-65-*-RAA-40*	CPV2R2-65-R-40
PV2R1-17-*-RAA-40*	CPV2R1-17-R-40	PV2R3-76-*-RAA-30*	CPV2R3-76-R-30
PV2R1-19-*-RAA-40*	CPV2R1-19-R-40	PV2R3-94-*-RAA-30*	CPV2R3-94-R-30
PV2R1-23-*-RAA-40*	CPV2R1-23-R-40	PV2R3-116-*-RAA-30*	CPV2R3-116-R-30
PV2R1-25-*-RAA-40*	CPV2R1-25-R-40	PV2R4-136-*-RAA-30*	CPV2R4-136-R-30
PV2R1-31-*-RAA-40*	CPV2R1-31-R-40	PV2R4-153-*-RAA-30*	CPV2R4-153-R-30
		PV2R4-184-*-RAA-30*	CPV2R4-184-R-30
		PV2R4-200-*-RAA-30*	CPV2R4-200-R-30
		PV2R4-237-*-RAA-30*	CPV2R4-237-R-30

● Seals & Bearings

Item	Name of Parts	Part Numbers				Qty.
		PV2R1	PV2R2	PV2R3	PV2R4	
9*	Oil Seal	ISD 26 42 8	ISD 30 42 8	ISD 35 55 11	ISD 45 68 12	1
10*	O-Ring	SO-NB-G80	SO-NB-G105	SO-NB-G135	SO-NB-G145	1
11*	O-Ring	---	---	---	SO-NB-P28	1
12*	O-Ring	---	---	---	SO-NB-P22A	1
13*	O-Ring	SO-NB-G60	SO-NB-G85	SO-NB-G115	SO-NA-G130	1
14*	O-Ring	SO-NB-G30	SO-NB-P46	SO-NB-A231	SO-NA-G80	1
15*	Back Up Ring	---	---	---	SO-BE-G130	1
16*	Back Up Ring	---	---	---	SO-BB-G80	1
17	Bearing	6004	6205	6207	6209	1

Note: 1) Item Nos. ⑬ and ⑭ (o-rings) and ⑮ and ⑯ (back up rings) are included in cartridge kit.

2) For pumps for phosphate ester type hydraulic fluids different part Nos. are used. Please contact us.

★ When ordering seals, please specify the kit number from the table right.

Pump Model Numbers	Seal Kit Numbers
PV2R1-*-*-RAA-40/4090	KS-PV2R1-40
PV2R2-*-*-RAA-40/4090	KS-PV2R2-40
PV2R3-*-*-RAA-30/3090	KS-PV2R3-30
PV2R4-*-*-RAA-30/3090	KS-PV2R4-30