

## 4801P pH/ORP controller



### **Introduction:**

Thank you for choosing this pH/ORP controller. This 1/16 DIN controller offers dual backlight LCD display, high accuracy, LED indicators, two control relays, and automatic or manual temperature compensation.

### **Specifications:**

	<b>pH</b>	<b>ORP</b>	<b>Temp.</b>
Range	-2.00~16.00 pH	-1999 ~ -200 mV -199.9 ~ 499.9 mV 500 ~ 1999 mV	0~110 °C
Accuracy	±0.01+1 digit	±2+1 digit	±0.2+1 digit
Resolution	0.01 pH	0.1/1 mV	0.1 °C
Compensation	ATC: 0~100 °C	N/A	

Deadband	pH: 0.00 to 2.00 pH ORP: 0 to 200 mV
Temperature Compensation	ATC (0-100°C) via 30K Thermistor or MTC
Limit Relays (2)	SPDT contacts rated for 5A at 115V
Relay status indicators	Front panel LED lamp
Power supply	9V DC
Panel Cutout	1/16th DIN 1.81 x 1.81" (46 x 46mm)
Meter Dimensions	4.7 x 1.77 x 1.77" (105 x 45 x 45mm)

### **Accessories:**

9V DC/AC(100~240V) adaptor

Adapter connection wire

## Installation:

### <Mounting the controller>

1. Make a 1.77 x 1.77" (45 x 45 mm) panel cutout (1/8" to 3/8" thickness)
2. Slide the controller into the cutout until the bezel is flush with the panel.
3. Slide the mounting bracket over the rear of the controller and press snugly against the rear of the panel.

### <Rear panel connection>

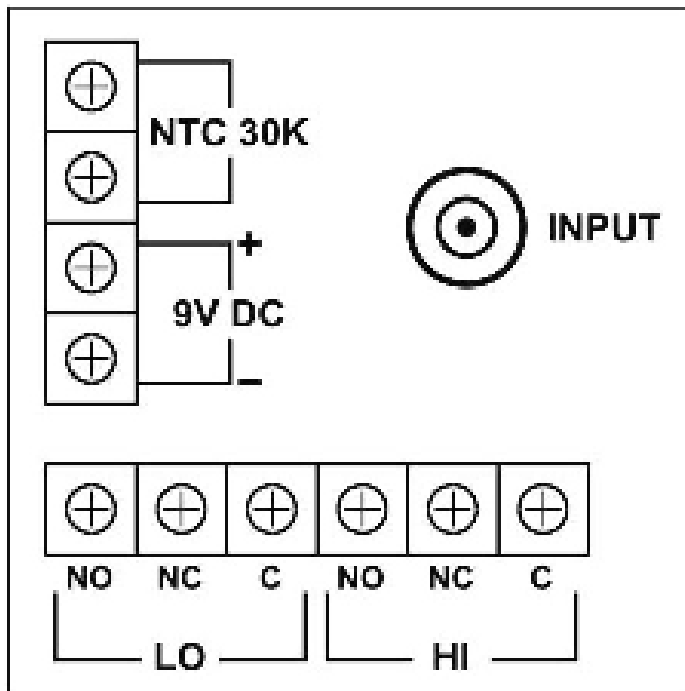

Connect the alarm/control devices to the HI or LO relay terminals.





The SPDT relays are dry contact type and the terminal designations are:

**C**: Common, **NO**: Normally Open, **NC**: Normally Closed

<Display and Buttons>



1. pH or ORP reading
2. Calibration mode
3. Calibration error indicator
4. HI relay energized LED indicator
5. LO relay energized LED indicator
6. Auto temperature compensation(ATC) or Manual temperature compensation(MTC)
7. Temperature reading and unit
8. unit of pH or ORP reading

	<ol style="list-style-type: none"> <li>1. Turn on/off the controller</li> <li>2. Enter calibration mode</li> </ol>
	<ol style="list-style-type: none"> <li>1. Switch pH and ORP mode</li> <li>2. Press and hold to enter setting mode</li> <li>3. In setting mode, press to store each setting</li> </ol>
	<ol style="list-style-type: none"> <li>1. In measurement mode, adjust temperature value of MTC</li> </ol>
	<ol style="list-style-type: none"> <li>2. In setting mode, adjust each parameter</li> </ol>

## Calibration:

### <pH>

1. Make sure the sensor is pH electrode and switch mode to pH mode.
2. Dip the electrode and the temperature probe into the buffer solution pH 7.00. Stir gently and wait until the reading is stable. Press and hold  for 3 sec. to enter calibration mode. The display will appear **CAL** and flashing 7.00. When the display stops flashing and indicates “SA”, then “End” while calibration ends, and will return to measurement mode.
3. Rinse the electrode and the probe with clean water and wipe it dry. Dip the electrode and the probe into the buffer solution pH 4.01 as previous steps.
4. After slope calibration, pH 4.01 or pH 10.01, the display will indicate the percentage of slope (PTS) to show the status of the electrode. If the PTS is below 70% or above 130%, the electrode must be replaced. A slope of 100% is ideal.

### Note:

1. Calibration error indicator icon will appear, and “Err” instead of “SA”, if calibration fails.
2. When doing a 2 or 3 points calibration, Calibrate with buffer pH 7 first, and then follow with buffer pH 4 or pH 10.







### <pH Calibration type and temperature unit setting>

This controller has two pH calibration type: USA and NIST, and the calibration points are following:

“USA”: 1.68, 4.01, 7.00, 10.01 and 12.45.

“NIST”: 1.68, 4.01, 6.86, 9.18 and 12.45.

To change calibration type and temperature unit:

1. Press and hold  until a beep sound, and then press  again.
2. The display will show the current pH calibration type. Press  to change the type, and then press  to store the setting.
3. The display will then show the current temperature unit. Press  to change the type, and then press  to store the setting.

### <ORP>

Calibration is not necessary for ORP. However, it could be tested with specific ORP standard solution to check whether the electrode is good.

## HI, LO and Deadband Setpoints

### <HI and LO Relay>

Relays switch state when their user-programmable setpoint is exceeded. They switch again when the limit is no longer exceeded. If the measurement exceeds the high setpoint, the high relay will switch state. If the measurement is lower than the low setpoint, the low relay will switch state. The programming steps are detailed later in this section.

### <HI and LO Deadband>

The Deadband feature is used to minimize relay chatter (rapid on/off relay switching) near setpoint. This is accomplished by creating a region where no relay action can occur. The High Deadband parameter creates a band at the high setpoint and the Low Deadband parameter creates a band at the low setpoint.

HI relay ON: reading  $>$  (HI relay setpoint + HI deadband)





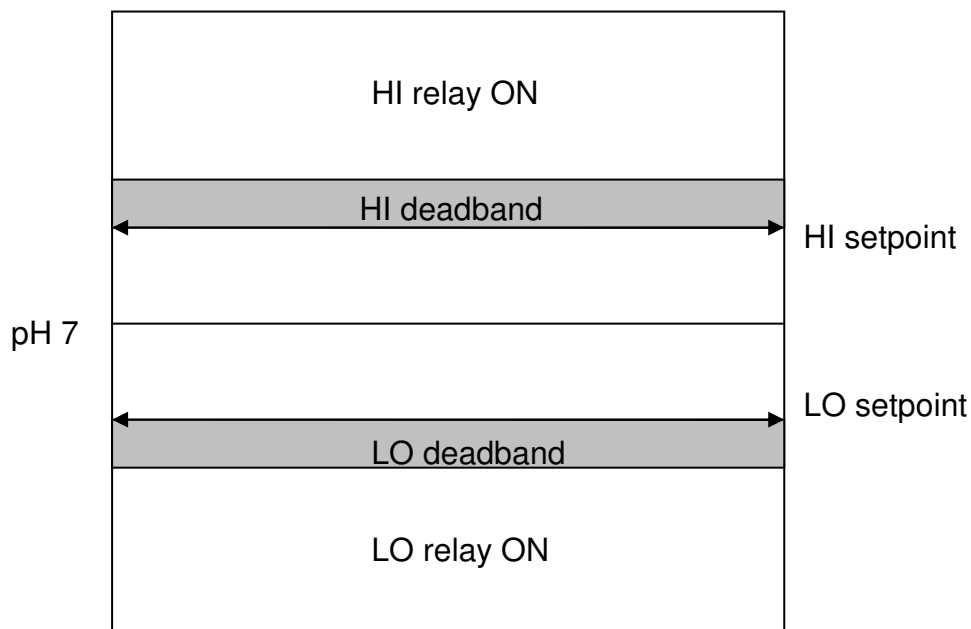

HI relay OFF: reading  $<$  (HI relay setpoint)

LO relay ON: reading  $<$  (LO relay setpoint - LO deadband)

LO relay OFF: reading  $>$  (LO relay setpoint)



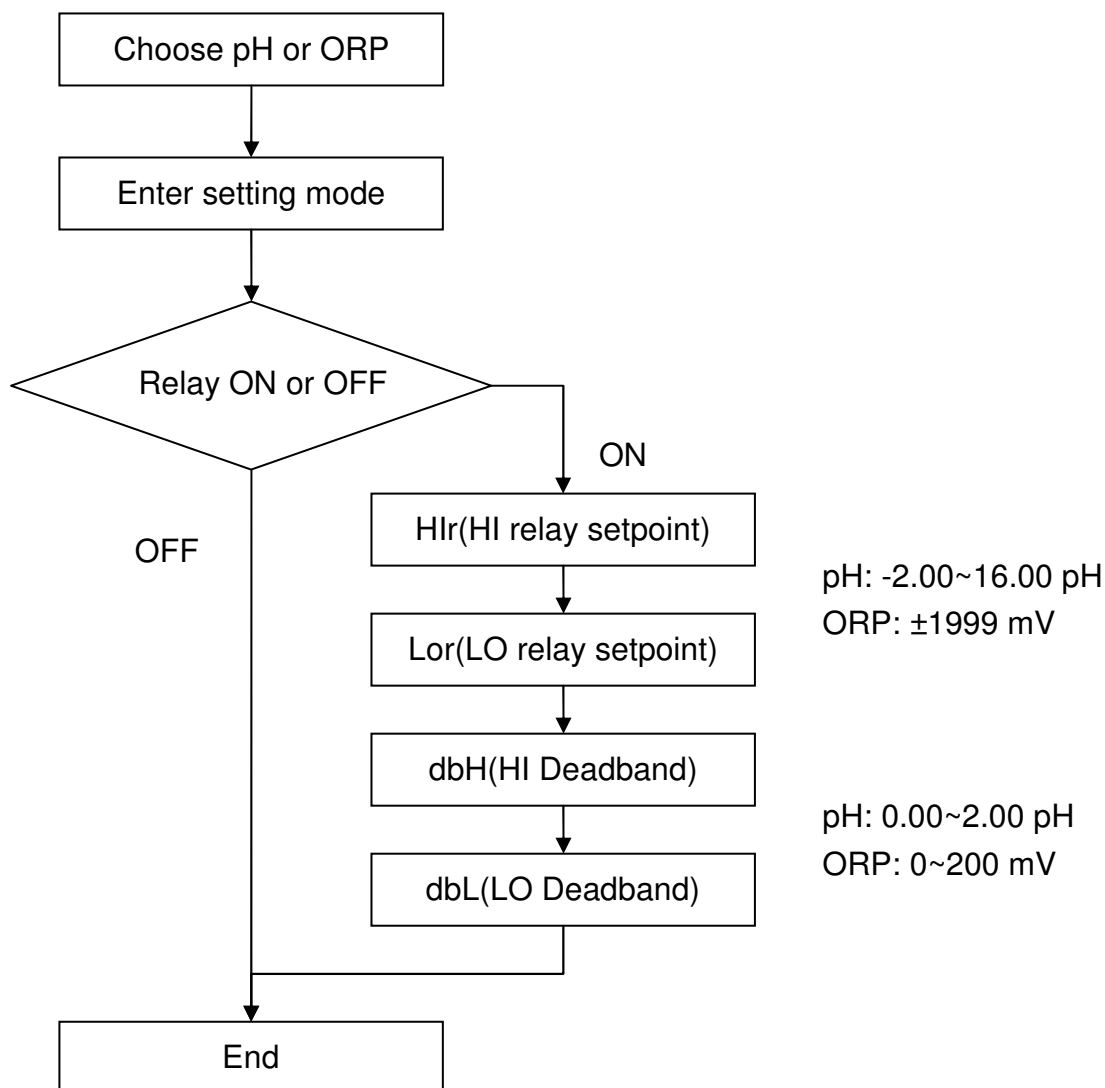

**< Programming the Setpoints and the Deadband >**

1. Press  to choose pH or ORP mode. The controller will store the settings for pH and ORP separately.
2. Press and hold  button until a beep sound, and then press  to enter setting mode. Use  and  to adjust settings, and use  to store each setting.
3. The display will then automatically cycle through 5 settings: rl(relay) on or off, Hlr(HI relay setpoint), Lor(LO relay setpoint), dbH(HI Deadband), and dbL(LO Deadband).
4. When setting HI or LO setpoints, press and hold  to switch the value to Positive or to Negative.



## Other settings

### <Back light>

1. Press and hold  until a beep sound, release  and then press and hold  again.



2. Press  to choose On, OFF, and Auto:



On: back light is always on.

OFF: back light is always off.

Auto: back light will be on for 30 seconds while any button is pressed and then off.

### <Reset the controller to default setting>

1. Press and hold  until a beep sound, release  and then press and hold  again until a beep sound.

2. Press  to switch OFF to On, and then press  to reset the controller to default setting.