



## E Series Relief Valves EBG-03/06/10 (3/8, 3/4, 1-1/4) Sub-plate Mounting

PROPORTIONAL  
CONTROLS

### Specifications / Model Number Designation

#### Specifications

Model Numbers	EBG-03	EBG-06	EBG-10
Description			
Max. Operating Pres. MPa (PSI)	24.5 (3550)	24.5 (3550)	24.5 (3550)
Max. Flow L/min(U.S.GPM)	100 (26.4)	200 (52.8)	400 (106)
Min. Flow L/min(U.S.GPM)	3 (.79)	3 (.79)	3 (.79)
Pressure Adjustment Range MPa (PSI)	Refer to Model Number Designation		
Rated Current	<b>C</b> : 770 mA <b>H</b> : 820 mA	<b>C</b> : 750 mA <b>H</b> : 800 mA	<b>C</b> : 730 mA <b>H</b> : 780 mA
Coil Resistance	10 Ω	10 Ω	10 Ω
Hysteresis	Less than 3%	Less than 3%	Less than 3%
Repeatability	Less than 1%	Less than 1%	Less than 1%
Approx. Mass kg (lbs.)	5.6 (12.3)	6.3 (13.9)	10 (22)

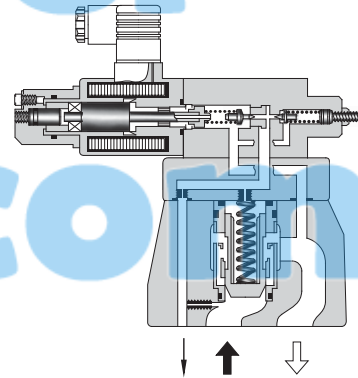
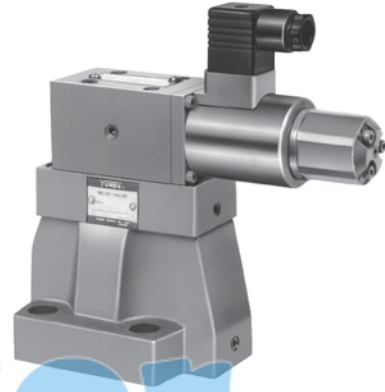

#### Model Number Designation

EB	G	-03	-C	-T	-51	*
Series Number	Type of Mounting	Valve Size	Pres. Adj. Range MPa (PSI)	Safety Valve	Design Number	Design Standards
<b>EB</b> : Proportional Electro-Hydraulic Relief Valve	<b>G</b> : Sub-plate Mounting	<b>03</b>	<b>C</b> : * - 15.7 (* - 2275) <b>H</b> : * - 24.5 (* - 3550)	<b>None</b> : With Safety Valve  <b>T</b> : Without Safety Valve	<b>51</b>	Refer to ★2
		<b>06</b>				
		<b>10</b>				

★1. Min. adjustment pressure shall be referred to the curves on page 16.

★2. Design Standards: None ..... Japanese Standard "JIS" and European Design Standard  
90 ..... N. American Design Standard

#### Graphic Symbols

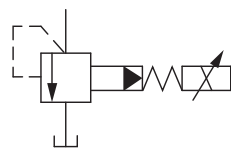

Without Safety Valve

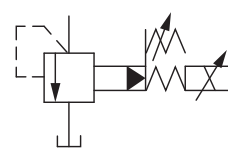

With Safety Valve





## E Series Relief Valves EBG-03/06/10

PROPORTIONAL  
CONTROLS

Sub-plate / Instructions / Others

- Attachment
- Mounting Bolts

Valve Model Numbers	Socket Head Cap Screw		
	Japanese Standard "JIS" & European Design Standard	N. American Design Standard	Qty.
EBG-03	M12 × 40 Lg.	1/2 - 13 UNC × 1-1/2 Lg.	4
EBG-06	M16 × 50 Lg.	5/8 - 11 UNC × 2 Lg.	4
EBG-10	M20 × 60 Lg.	3/4 - 10 UNC × 2-1/4 Lg.	4

### ■ Applicable Power Amplifiers

For stable performance, it is recommended that Yuken's applicable power amplifiers be used (for details see Catalogue No. Pub. EC-1305).

Model Numbers: AME-D-10-\*\*-20      SK1015-11 (For DC power supply)  
 AME-D2-1010-\*\*-10      AMN-D-10 (For DC power supply)  
 SK1022-\*\*-\*-11

### ■ Sub-plate

Valve Model Numbers	Japanese Standard "JIS"		European Design Standard		N. American Design Standard		Approx. Mass kg (lbs)
	Sub-plate Model Numbers	Thread Size	Sub-plate Model Numbers	Thread Size	Sub-plate Model Numbers	Thread Size	
EBG-03	BGM-03-20	Rc 3/8	BGM-03-3080	3/8 BSP.F	BGM-03-2090	3/8 NPT	2.4 (5.3)
	BGM-03X-20	Rc 1/2	BGM-03X-3080	1/2 BSP.F	BGM-03X-2090	1/2 NPT	3.1 (6.8)
EBG-06	BGM-06-20	Rc 3/4	BGM-06-3080	3/4 BSP.F	BGM-06-2090	3/4 NPT	4.7 (10.4)
	BGM-06X-20	Rc 1	BGM-06X-3080	1 BSP.F	BGM-06X-2090	1 NPT	5.7 (12.6)
EBG-10	BGM-10-20	Rc 1-1/4	BGM-10-3080	1-1/4 BSP.F	BGM-10-2090	1-1/4 NPT	8.4 (18.5)
	BGM-10X-20	Rc 1-1/2	BGM-10X-3080	1-1/2 BSP.F	BGM-10X-2090	1-1/2 NPT	10.3 (22.7)

- Sub-plates are available. Specify the sub-plate model number from the table above. When sub-plates are not used, the mounting surface should have a good machined finish.

### ■ Instructions

#### ● Safety Valve

The pressure of the safety valve for EBG-03 is preset at the value equal to the upper limit of the pressure adjustment range plus 2 MPa (290 PSI) subject to a flow rate of 50 L/min (13.2 U.S.GPM).

The same for EBG-06 is preset at the value equal to the upper limit of the pressure adjustment range plus 3.5 MPa (510 PSI) subject to a flow rate of 100 L/min (26.4 U.S.GPM).

The same for EBG-10 is preset at the value equal to the upper limit of the pressure adjustment range plus 4 MPa (580 PSI) subject to a flow rate of 200 L/min (52.8 U.S.GPM).

In case where the upper limit of operating pressure is low or the upper limit of flow rate to be used is different from the specified maximum flow, please adjust and determine the setting pressure of the safety valve at the value calculated from the following formula.

$$\text{Setting pressure} = (\text{Operating pressure upper limit}) + (\text{Additional pressure indicated blow})$$

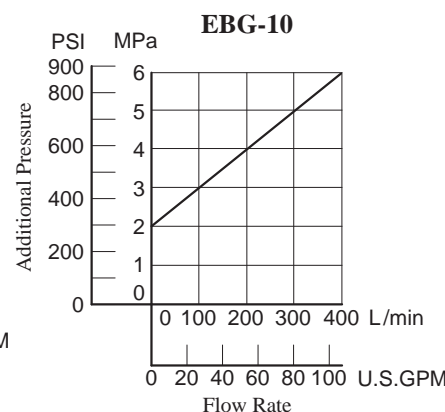
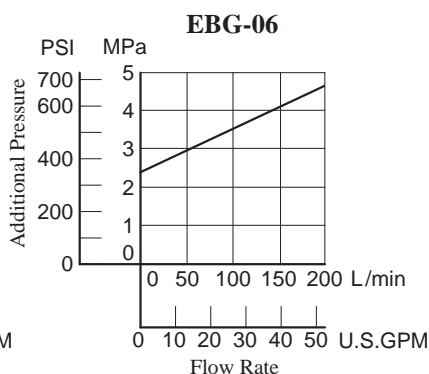
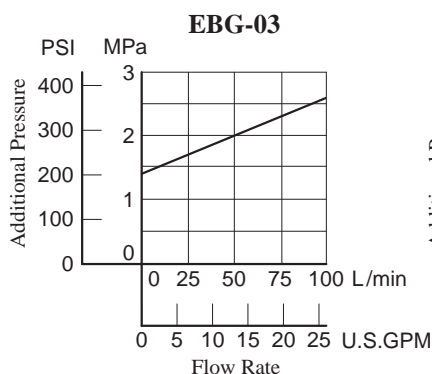

To lower the setting pressure, turn the safety valve pressure adjustment screw anti-clockwise. After adjustment, be sure to tighten the lock nut.



**E Series  
Relief Valves  
EBG-03/06**

**PROPORTIONAL  
CONTROLS**

**Installation Drawing**

EBG-03  
06-\* -51/5190

With Safety Valve

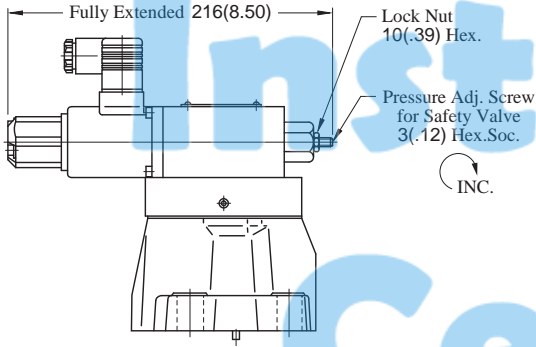

• For other dimensions, refer to the without safety valve.

Mounting Surface  
EBG-03 : ISO 6264-AR-06-2-A  
EBG-06 : ISO 6264-AS-08-2-A

**DIMENSIONS IN  
MILLIMETRES (INCHES)**

EBG-03  
06-\* -T-51/5190

Without Safety Valve

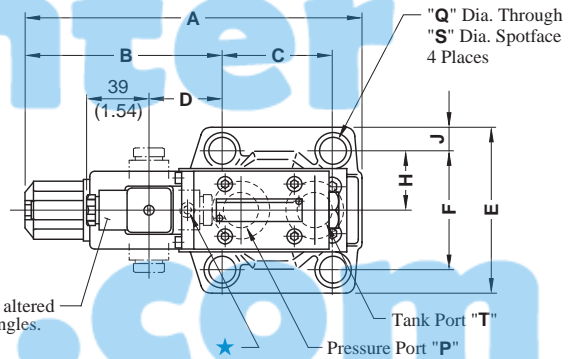

★ This port is not used. It is provided because of the common use of the body with the low-noise relief valve. On the sub-plate, plug the port which corresponds to this port.

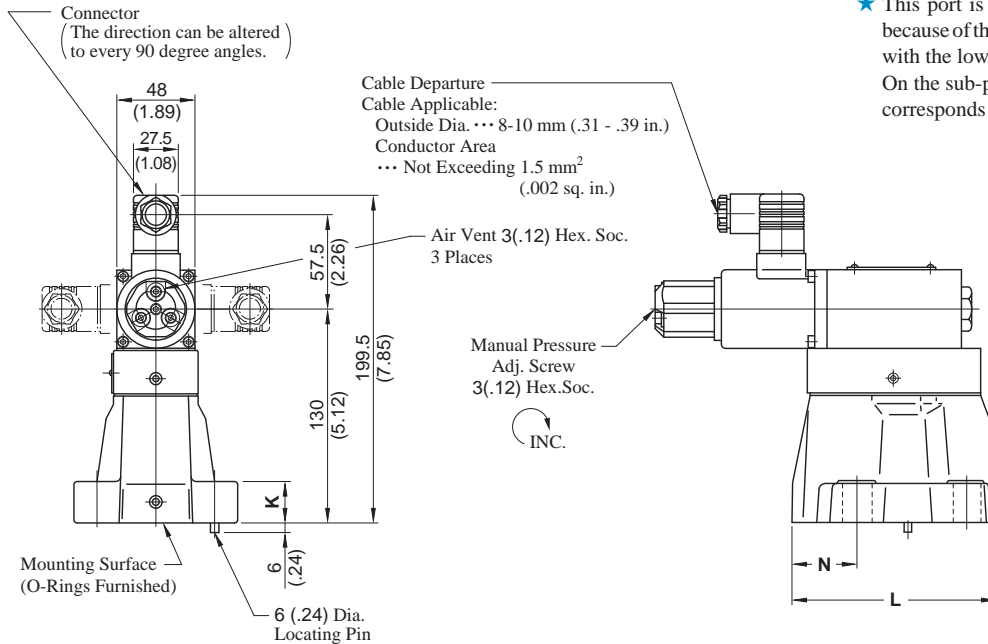

Model Numbers	Dimensions mm (Inches)												
	A	B	C	D	E	F	H	J	K	L	N	Q	S
EBG-03	197.5 (7.78)	117.6 (4.63)	53.8 (2.12)	40.3 (1.59)	76 (2.99)	53.8 (2.12)	26.9 (1.06)	11.1 (.44)	21.5 (.85)	106 (4.17)	26.1 (1.03)	13.5 (.53)	21 (.83)
EBG-06	205.5 (8.09)	119.5 (4.70)	66.7 (2.63)	42.2 (1.66)	98 (3.86)	70 (2.76)	35 (1.38)	14 (.55)	26 (1.02)	122 (4.80)	36 (1.42)	17.5 (.69)	26 (1.02)





# E Series Relief Valves EBG-10

PROPORTIONAL  
CONTROLS

## Installation Drawing

EBG-10-\* -51/5190

With Safety Valve

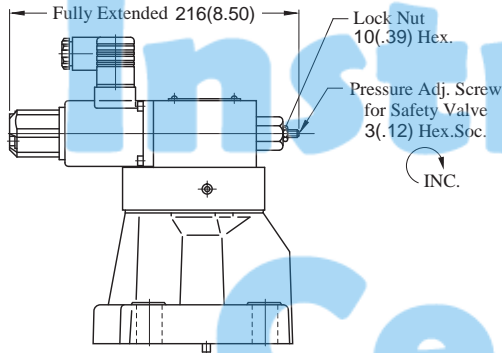

• For other dimensions, refer to the without safety valve.

Mounting surface:  
ISO 6264-AT-10-2-A

DIMENSIONS IN  
MILLIMETRES (INCHES)

EBG-10-\* -T-51/5190

Without Safety Valve

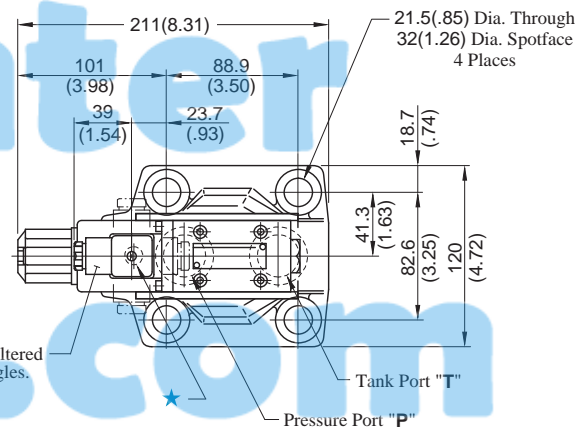

The direction can be altered to every 90 degree angles.

★ This port is not used. It is provided because of the common use of the body with the low-noise relief valve. On the sub-plate, plug the port which corresponds to this port.

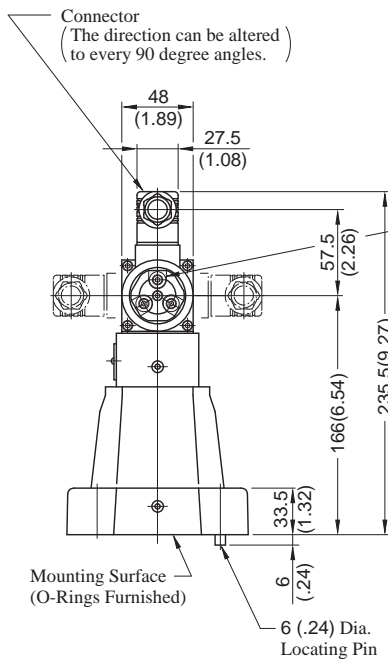

Cable Departure  
Cable Applicable:  
Outside Dia. ... 8-10 mm (.31 - .39 in.)  
Conductor Area  
... Not Exceeding 1.5 mm<sup>2</sup>  
(.002 sq. in.)

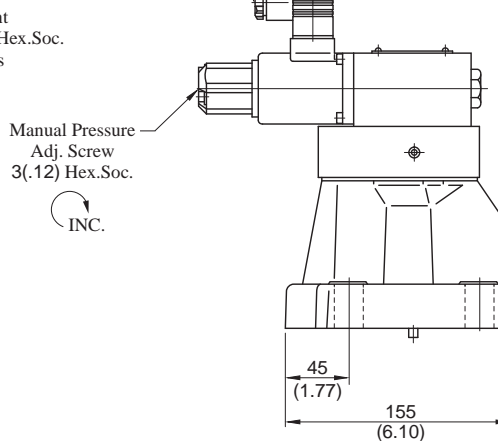



## E Series Sub-plate for Relief Valves

PROPORTIONAL  
CONTROLS

### Installation Drawing

BGM-03,03X-20/3080/2090  
Sub-plate: BGM-06,06X-20/3080/2090  
BGM-10,10X-20/3080/2090

DIMENSIONS IN  
MILLIMETRES (INCHES)

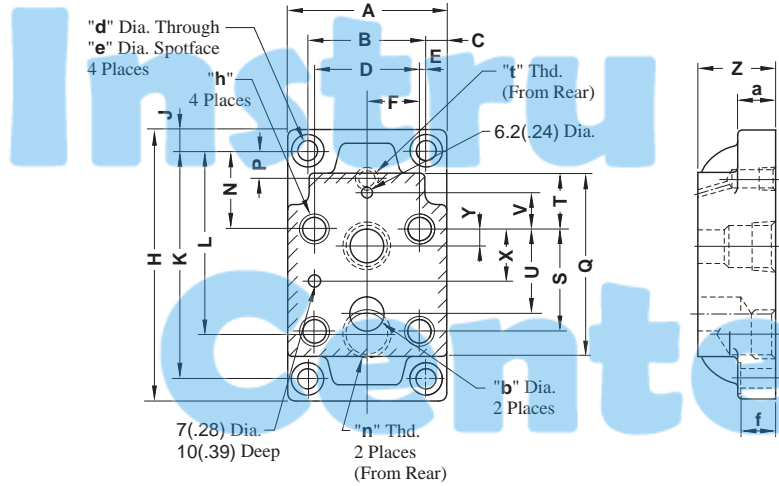

Model Numbers	Dimensions mm (Inches)													
	A	B	C	D	E	F	H	J	K	L	N	P	Q	S
BGM-03	86	60	13	53.8	3.1	26.9	149	13	123	86	26	32	97	53.8
BGM-03X	(3.39)	(2.36)	(.51)	(2.12)	(.12)	(1.06)	(5.87)	(.51)	(4.84)	(3.39)	(1.02)	(1.26)	(3.82)	(2.12)
BGM-06	108	78	15	70	4	35	180	15	150	106.5	27.2	51	121	66.7
BGM-06X	(4.25)	(3.07)	(.59)	(2.76)	(.16)	(1.38)	(7.09)	(.59)	(5.91)	(4.19)	(1.07)	(2.01)	(4.76)	(2.63)
BGM-10	126	94	16	82.6	5.7	41.3	227	16	195	138.2	30.2	62	154	88.9
BGM-10X	(4.96)	(3.70)	(.63)	(3.25)	(.22)	(1.63)	(8.94)	(.63)	(7.68)	(5.44)	(1.19)	(2.44)	(6.06)	(3.50)

Model Numbers	Dimensions mm (Inches)										
	T	U	V	X	Y	Z	a	b	d	e	f
BGM-03	19	47.4	0	22	22	32	20	14.5	11	17.5	19
BGM-03X	(.75)	(1.87)	(0)	(.87)	(.87)	(1.26)	(.79)	(.57)	(.43)	(.69)	(.75)
BGM-06	37	55.5	23.8	33.4	11	40	25	23	13.5	21	24
BGM-06X	(1.46)	(2.19)	(.94)	(1.31)	(.43)	(1.57)	(.98)	(.91)	(.53)	(.83)	(.94)
BGM-10	42	76.2	31.8	44.5	12.7	50	32	28	17.5	26	31
BGM-10X	(1.65)	(3.00)	(1.25)	(1.75)	(.50)	(1.97)	(1.26)	(1.10)	(.69)	(1.02)	(1.22)

Model Numbers	Japanese Standard "JIS" Design "20"			European Design Standard Design "3080"			N. American Design Standard Design "2090"		
	"h"	"n" Thd.	"t" Thd.	"h"	"n" Thd.	"t" Thd.	"h"	"n" Thd.	"t" Thd.
BGM-03	M12 Thd.	Rc 3/8	Rc 1/4	M12 Thd.	3/8 BSP.F	1/4 BSP.F	1/2-13UNC Thd.	3/8 NPT	1/4 NPT
BGM-03X	20(.79) Deep	Rc 1/2		20(.79) Deep	1/2 BSP.F		22(.87) Deep	1/2 NPT	
BGM-06	M16 Thd.	Rc 3/4		M16 Thd.	3/4 BSP.F		5/8-11UNC Thd.	3/4 NPT	
BGM-06X	25(.98) Deep	Rc 1		25(.98) Deep	1 BSP.F		27(1.06) Deep	1 NPT	
BGM-10	M20 Thd.	Rc1-1/4		M20 Thd.	1-1/4 BSP.F		3/4-10UNC Thd.	1-1/4 NPT	
BGM-10X	28(1.10) Deep	Rc 1-1/2	28(1.10) Deep	1-1/2 BSP.F	28(1.10) Deep	1-1/2 NPT			



**E SERIES  
Relief Valves  
EBG-03/0610**

**PROPORTIONAL  
CONTROLS**

**Typical Performance Characteristics**

**■ Min. Adjustment Pressure**

Viscosity : 30 mm<sup>2</sup>/s (141 SSU)

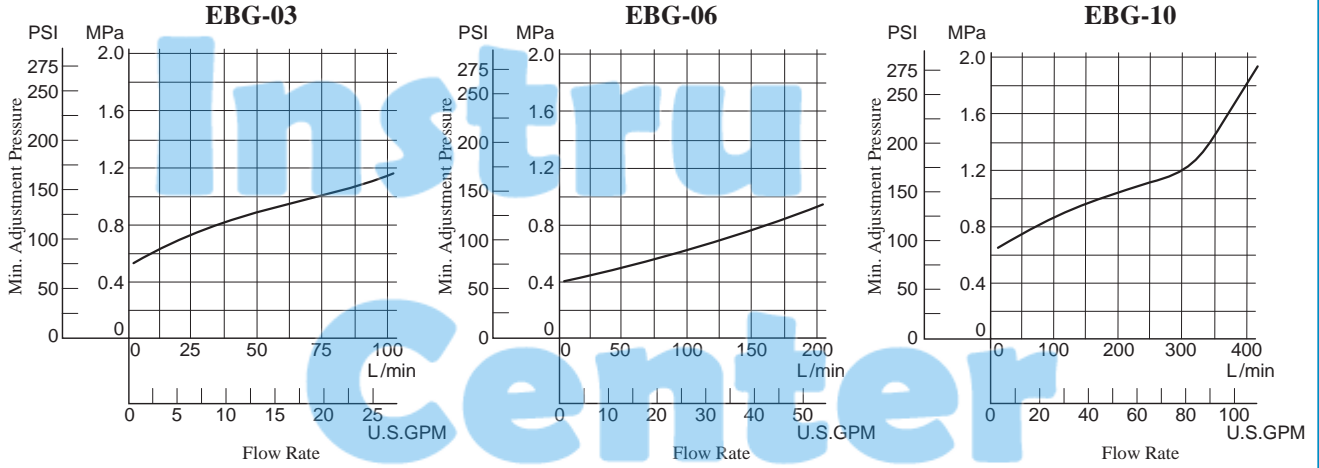

**■ Step Response (Example)**

These Characteristics have been obtained by measuring on each valve. Therefore, they may vary according to a hydraulic circuit to be used.

Trapped Oil Volume : 1 L (.264 U.S. Gallons)  
Viscosity : 30 mm<sup>2</sup>/s (141 SSU)

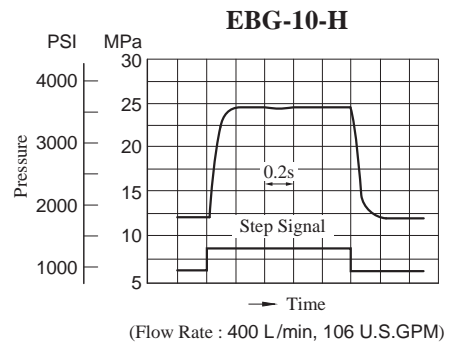
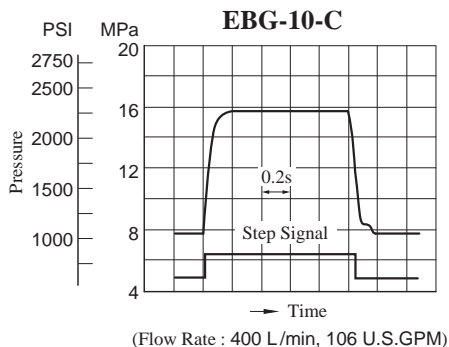
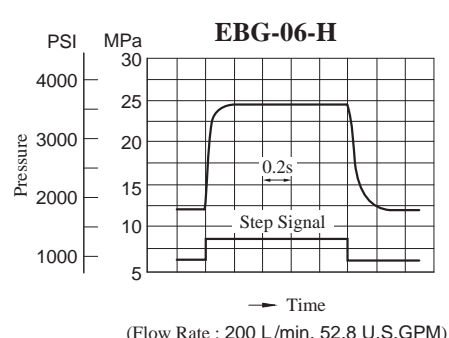
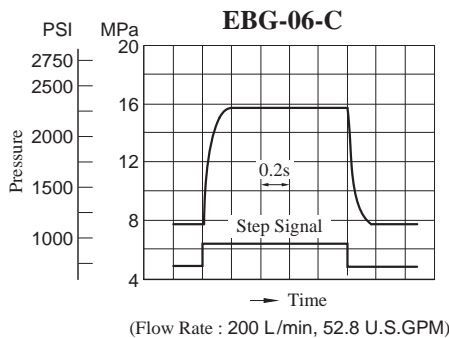
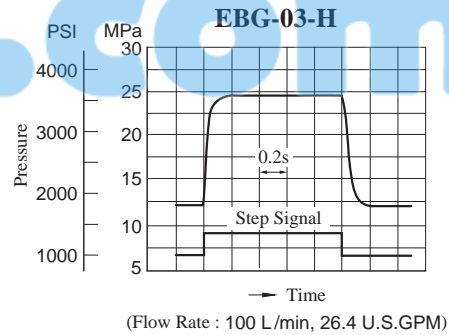
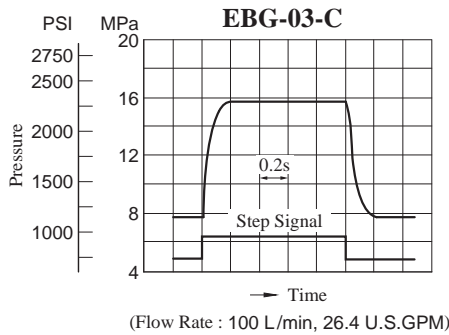



**E SERIES  
Relief Valves  
EBG-03/06/10**

**PROPORTIONAL  
CONTROLS**

**Typical Performance Characteristics**

**Input Current vs. Pressure**

**Frequency Response**

Trapped Oil Volume : 1 L (.264 U.S. Gallons)  
Viscosity : 30 mm<sup>2</sup>/s (141 SSU)

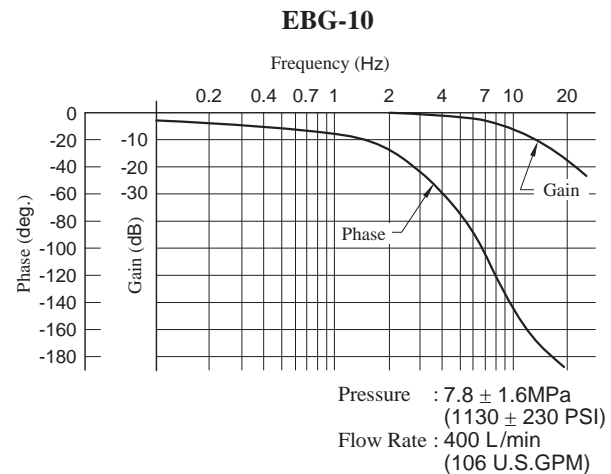
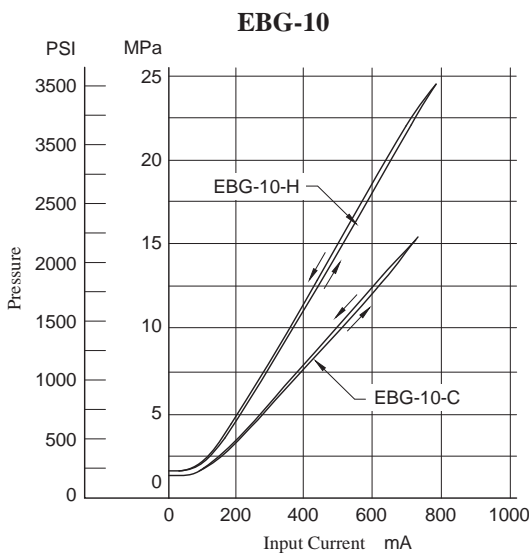
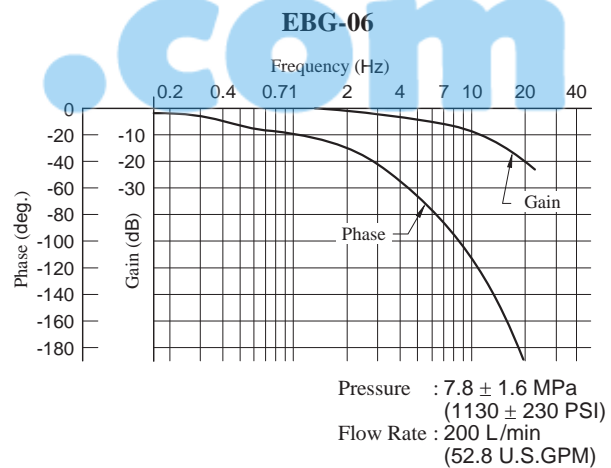
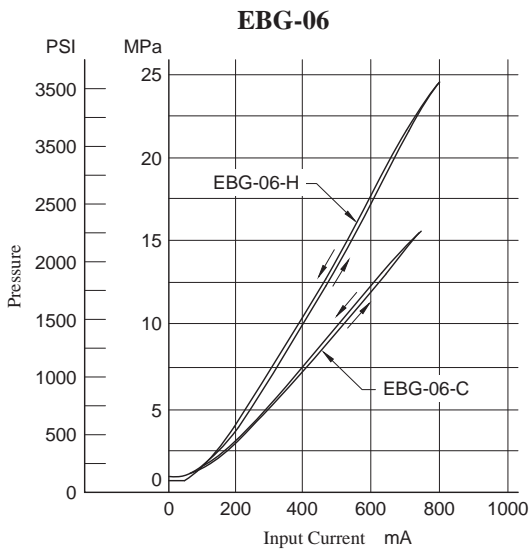
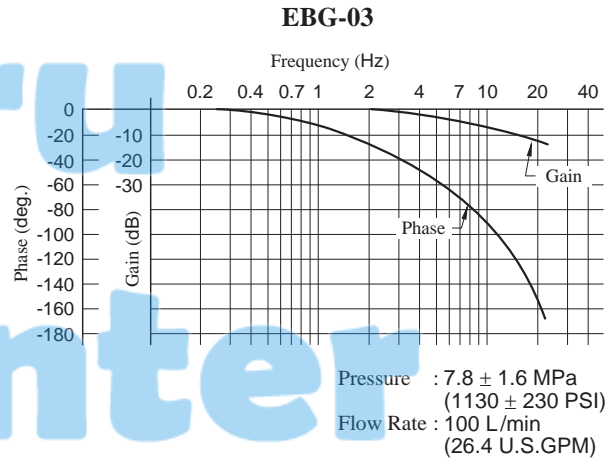
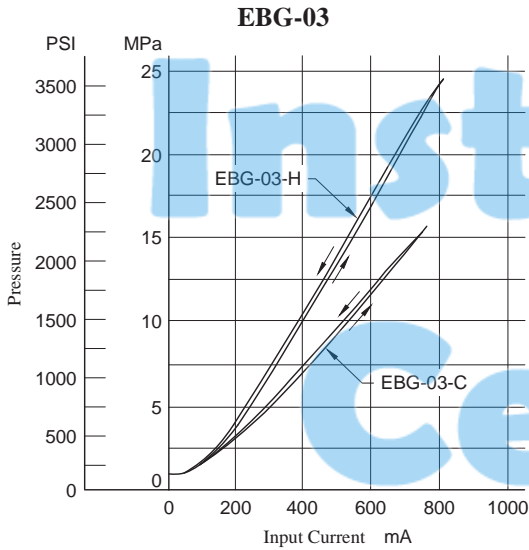





**E SERIES  
Relief Valves  
EBG-03/06/10**

**PROPORTIONAL  
CONTROLS**

**Typical Performance Characteristics**

**■ Viscosity vs. Pressure**

Oil : ISO VG 46 Oil

**■ Flow Rate vs. Pressure**

Viscosity : 30 mm<sup>2</sup>/s (141 SSU)

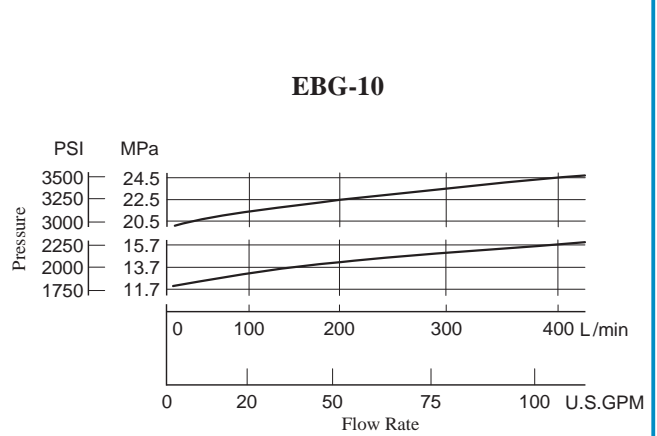
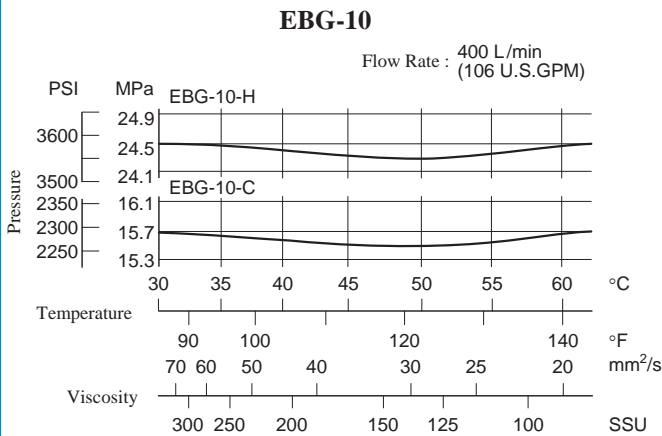
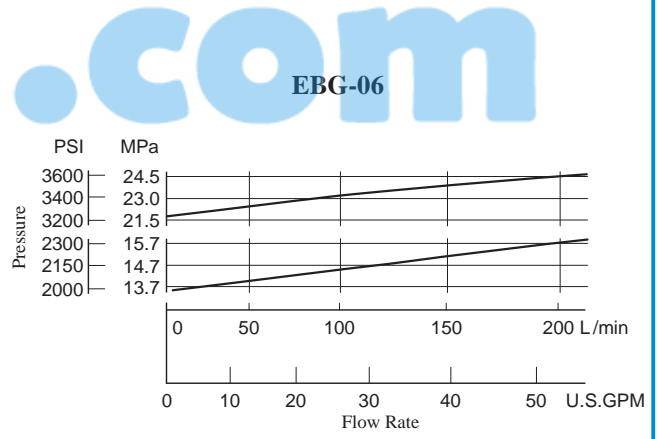
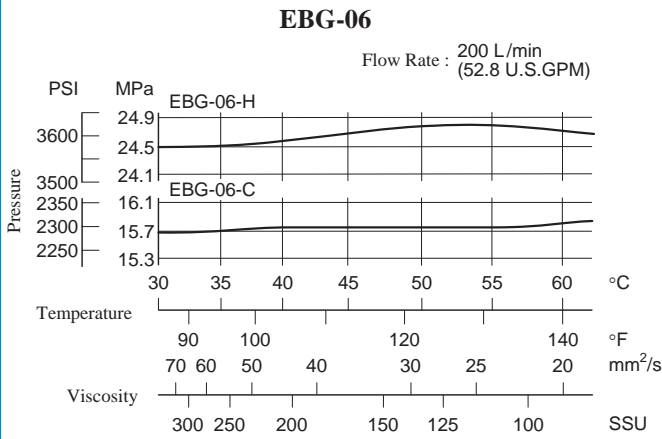
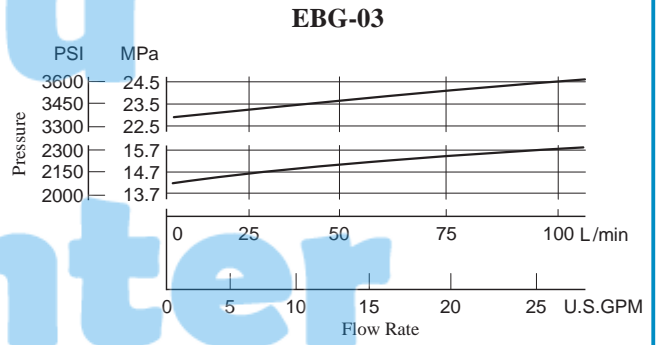
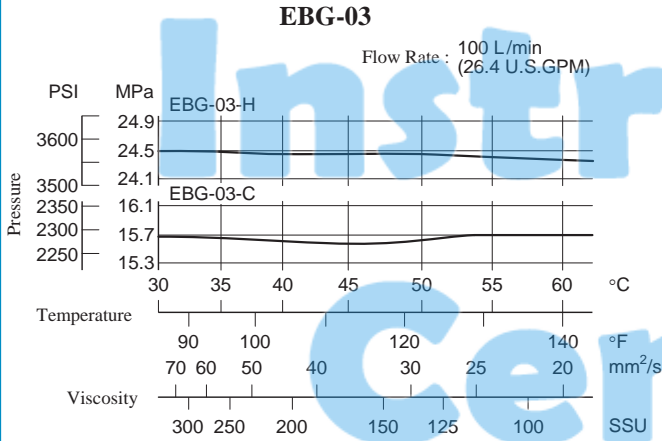





**E Series  
Relief Valves  
EBG-03/06/10**

**PROPORTIONAL  
CONTROLS**

**Spare Parts List**

03  
EBG-06-\*-\*-51/5190  
10

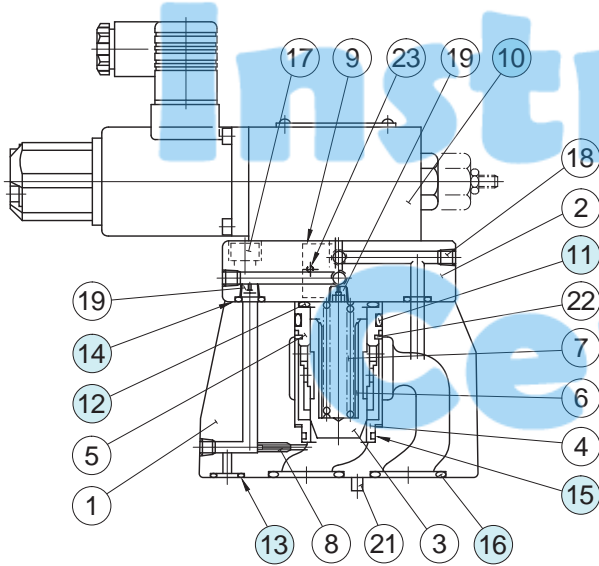

● Pilot Valve

Valve Model Numbers	⑩ Pilot Valve Model Numbers
EBG-03-C-51/5190	EDG-01V-C-1-PNT09-51
EBG-03-H-51/5190	EDG-01V-H-1-PNT09-51
EBG-03-C-T-51/5190	EDG-01V-C-PNT09-51
EBG-03-H-T-51/5190	EDG-01V-H-PNT09-51
EBG-06-C-51/5190	EDG-01V-C-1-PNT10-51
EBG-06-H-51/5190	EDG-01V-H-1-PNT10-51
EBG-06-C-T-51/5190	EDG-01V-C-PNT10-51
EBG-06-H-T-51/5190	EDG-01V-H-PNT10-51
EBG-10-C-51/5190	EDG-01V-C-1-PNT11-5103
EBG-10-H-51/5190	EDG-01V-H-1-PNT11-5103
EBG-10-C-T-51/5190	EDG-01V-C-PNT11-5103
EBG-10-H-T-51/5190	EDG-01V-H-PNT11-5103

Note: For the details of pilot valves, refer to "Pilot Relief Valves" on page 9.

● List of Seals

Item	Name of Parts	Part Numbers			Qty.
		EBG-03	EBG-06	EBG-10	
11	O-Ring	SO-NB-P32	SO-NB-P32	SO-NB-P42	1
12	O-Ring	SO-NB-P28	SO-NB-P28	SO-NB-P28	1
13	O-Ring	SO-NB-P9	SO-NB-P11	SO-NB-P9	1
14	O-Ring	SO-NB-P9	SO-NB-P9	SO-NB-P9	2
15	O-Ring	SO-NB-A024	SO-NB-A024	SO-NB-A128	1
16	O-Ring	SO-NB-P18	SO-NB-P28	SO-NB-P32	2

Note) When ordering seals, please specify the seal kit number from the table below.  
In addition to the above O-rings, O-rings for pilot valve are included in the seal kit.  
For the details of the pilot valve seals, see page 9.

● List of Seal Kit

Model Numbers	Seal Kit Numbers
EBG-03	KS-EBG-03-51
EBG-06	KS-EBG-06-51
EBG-10	KS-EBG-10-51

**CAUTION**

When making replacement of seals, please do it carefully after reading through the relevant instructions in the Operator's Manual.





## E Series Relief Valves EBG-03/06/10

PROPORTIONAL  
CONTROLS

### Interchangeability between Current and New Design

#### ■ Interchangeability between Current and New Design

EBG-03/06/10 series valves have changed model from 50 to 51 design in line with the model change of pilot valve (EDG-01).

#### ● Specifications and Characteristics

No change in specifications and characteristics between current and new design.

#### ● Mounting Interchangeability

There is an interchangeability in the mounting dimensions, however, the outside shape and dimensions are changed as shown below due to pilot valve improvement and other modifications.

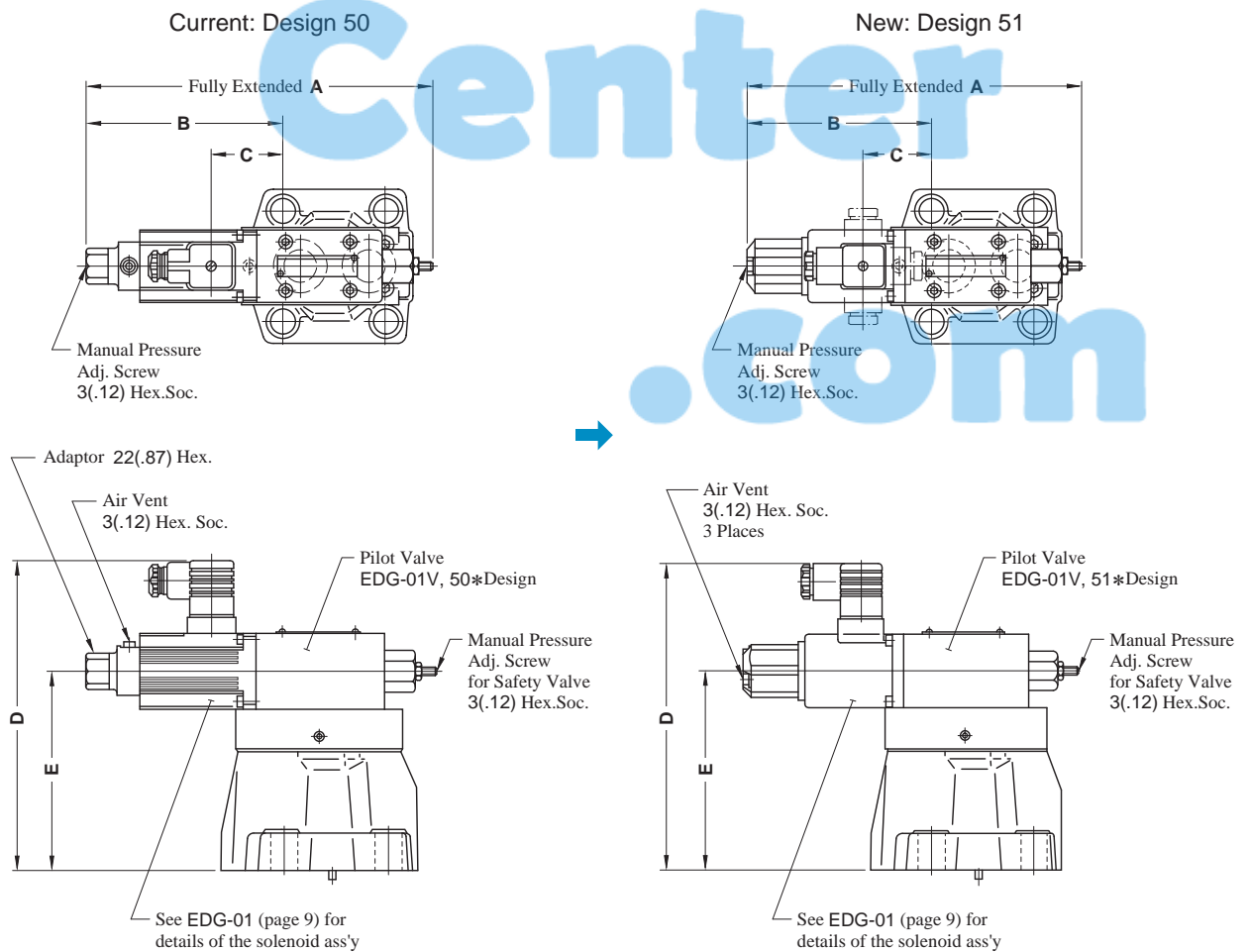

Model Numbers		A	B	C	D	E
Current	EBG-03-*-*-50/5090	217 (8.54)	118.6 (4.67)	40.2 (1.58)	199.5 (7.85)	130 (5.12)
New	EBG-03-*-*-51/5190	216 (8.50)	117.6 (4.63)	40.3 (1.59)		
Current	EBG-06-*-*-50/5090	217 (8.54)	120.5 (4.74)	42.1 (1.66)	199.5 (7.85)	130 (5.12)
New	EBG-06-*-*-51/5190	216 (8.50)	119.5 (4.70)	42.2 (1.66)		
Current	EBG-10-*-*-50/5090	217 (8.54)	102 (4.02)	23.6 (.93)	235.5 (9.27)	166 (6.54)
New	EBG-10-*-*-51/5190	216 (8.50)	101 (3.98)	23.7 (.93)		

DIMENSIONS IN  
MILLIMETRES (INCHES)