

Flow Control Valve

CF Series



Features and Handling

- CF Series are flow control valves with check valve. The valves control the flow in one direction and allow free flow in the other direction. With two step control range, the first three turns of the knob can control fine adjustment of low flow and the next three turns can open the valve to full flow. The knob comes with color bands for easy reading.



Ordering Code

CF - T04 - B

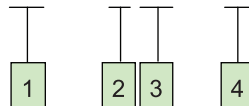

1 Model : CF

2 Mounting
T - Threaded connections

3 Valve size
02 - 1/4" 03 - 3/8"
04 - 1/2" 06 - 3/4"

4 Port Connection (Threaded connections only)

CF-T02	CF-T03
N - 1/4" NPT	N - 3/8" NPT
B - 1/4" BSP	B - 3/8" BSP
CF-T04	CF-T06
N - 1/2" NPT	N - 3/4" NPT
B - 1/2" BSP	B - 3/4" BSP

Specification and Installation Dimensions mm (inch)

CF

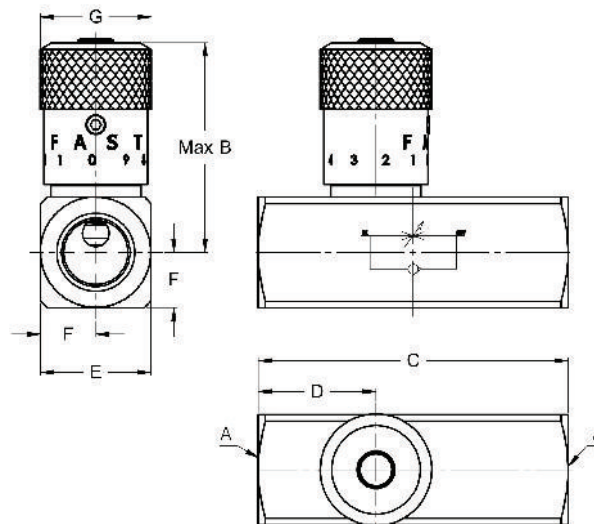

Model	Maximum Flow L/min (USgpm)	Maximum Pressure bar (psi)	Dimensions mm (inch)							Weight kg (lb)
			A Thread	B	C	D	E	F	G	
CF-T02	19 (5)	356 (5000)	1/4"NPT	40.4	66.5	26.6	25.4	12.7	20.6	0.27
			1/4"BSP	(1.59)	(2.62)	(1.05)	(1.00)	(0.50)	(0.81)	(0.59)
CF-T03	30 (8)		3/8"NPT	55.4	70.0	26.6	25.4	12.7	25.2	0.34
			3/8"BSP	(2.18)	(2.75)	(1.05)	(1.00)	(0.50)	(0.99)	(0.75)
CF-T04	57 (15)		1/2"NPT	68.6	87.0	33.0	31.7	15.9	29.8	0.68
			1/2"BSP	(2.70)	(3.42)	(1.30)	(1.25)	(0.63)	(1.17)	(1.50)
CF-T06	95 (25)	3/4"NPT	85.9	98.5	37.5	38.1	19.05	34.9	1.60	
		3/4"BSP	(3.38)	(3.88)	(1.48)	(1.50)	(0.75)	(1.37)	(3.52)	