

I. BRIEF INTRODUCTION

1.1 APPLICATION SCOPE

This series of motor, with its shell made of ductile cast iron of adequate intensity, can be applied to situations with less load and interval operation, widely to agriculture, forestry, plastics, machine tools and mining machines, such as the mould height adjustment of the injection molding machine, the cleaner, the sawmill, the worktable etc.

1.2 MAIN CHARACTERISTICS (drawing attached)

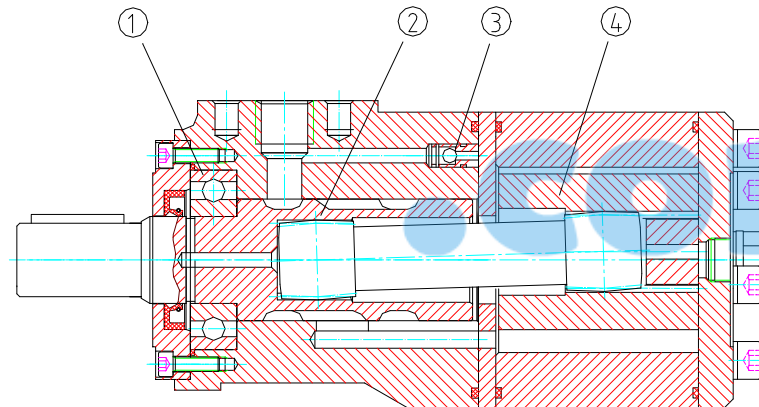

- 1) The output shaft, with the deep groove ball bearing, can bear certain axial force and radial force.
- 2) With the axial oil distribution structure, it is of smaller size and less weight.
- 3) With two inner check valves, it needs no outer oil drain.
- 4) With cycloid group with the roller, it has a small friction and high mechanical efficiency.

1.3 MAIN SPECIFICATIONS AND BASIC PARAMETERS

| Type BMR | Rated pressure (Mpa) | Speed range (r/min) | Max output power (Kw) | Weight (Kg) | Rated torque (N·M) | L (mm) |
|----------|------------------------|-----------------------|-------------------------|---------------|----------------------|--------|
| BMR-80 | 14 | 10-750 | 10 | 6.9 | 152 | 144 |
| BMR-100 | 14 | 10-600 | 10 | 7.0 | 194 | 148 |
| BMR-125 | 14 | 9-475 | 10 | 7.3 | 237 | 152 |
| BMR-160 | 14 | 7-375 | 10 | 7.5 | 310 | 158 |
| BMR-200 | 14 | 5-300 | 8 | 8.0 | 369 | 165 |
| BMR-250 | 11 | 5-240 | 6 | 8.5 | 380 | 174 |
| BMR-315 | 9 | 5-190 | 5 | 9.0 | 380 | 196 |

BMR INSTALLATION

BMR-50~400P1AY INSTALLATION

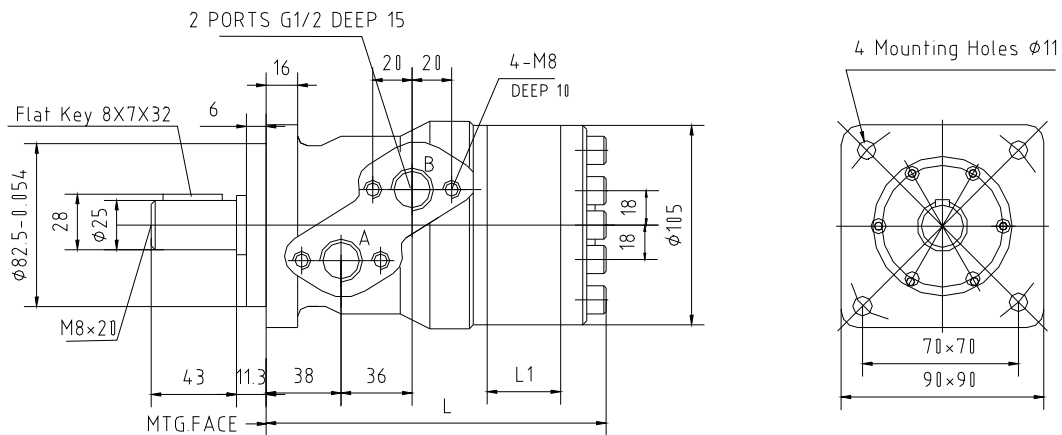

BMR-50~400H1AY INSTALLATION

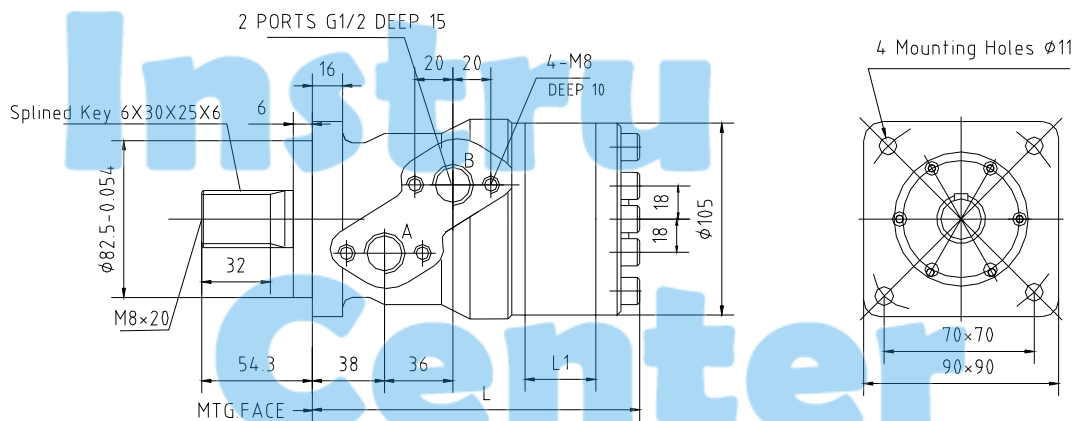

.com

BMR-50~400P1AII Y INSTALLATION

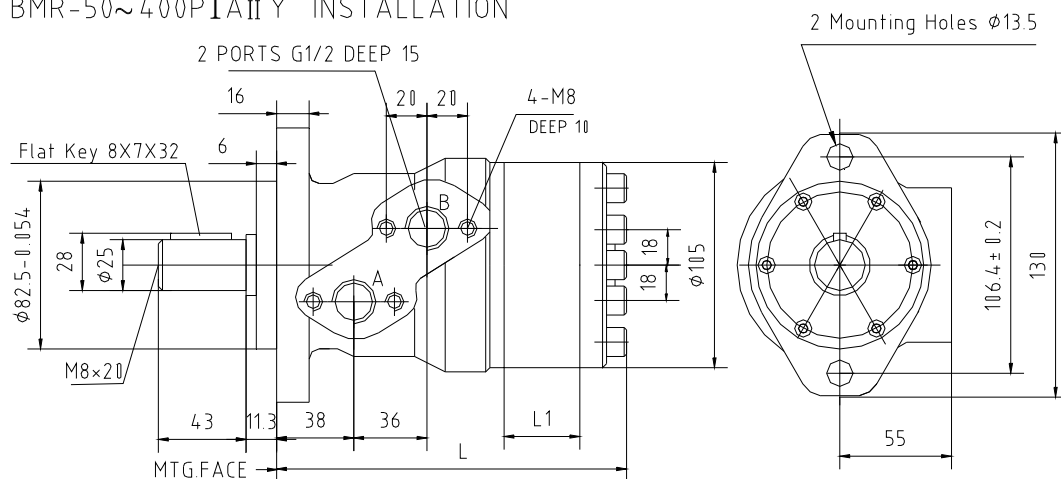

BHC ORBIT Hydraulic motors

BMR Manual

BMR-50~400H1AII Y INSTALLATION

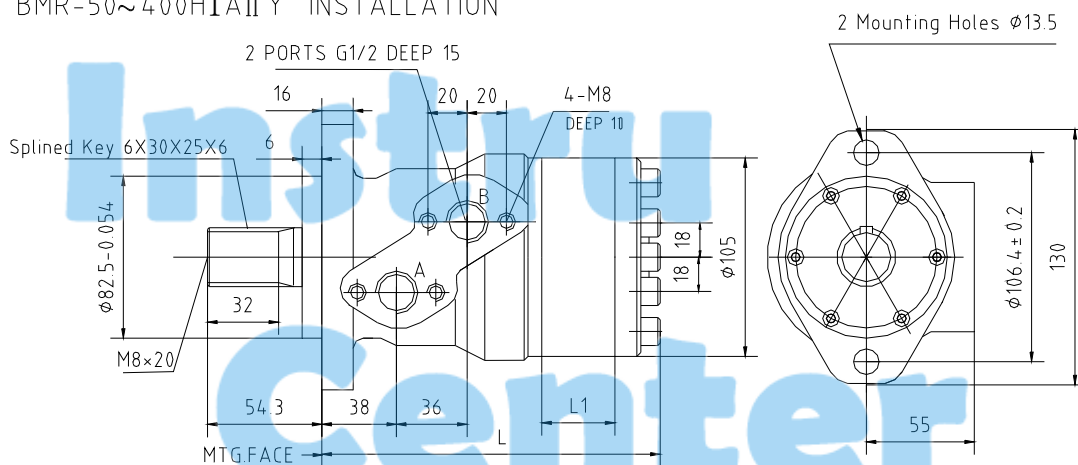

.com

BMR-50~400P1AIV Y INSTALLATION

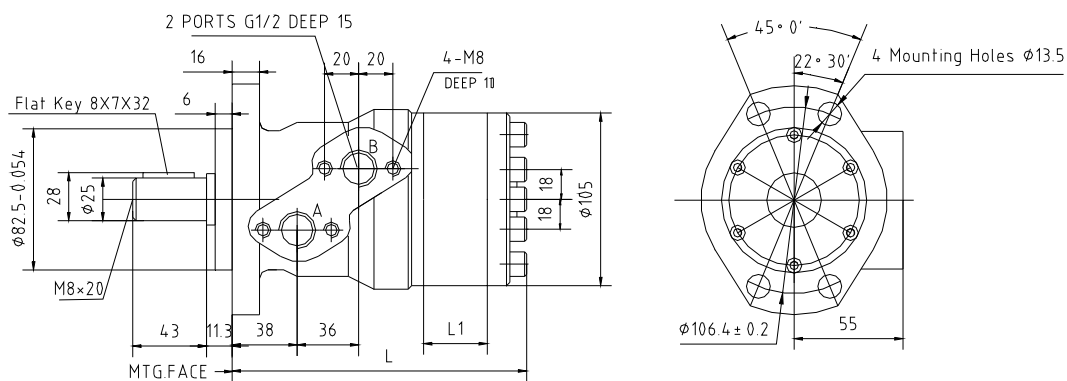

BMR-50~400H1A HY INSTALLATION

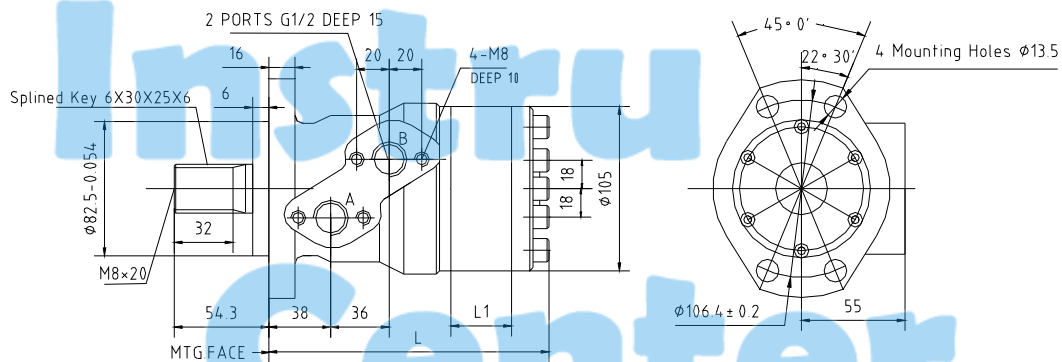

1.4 NAMEPLATE (drawing attached): nameplate location and the drawing of the nameplate

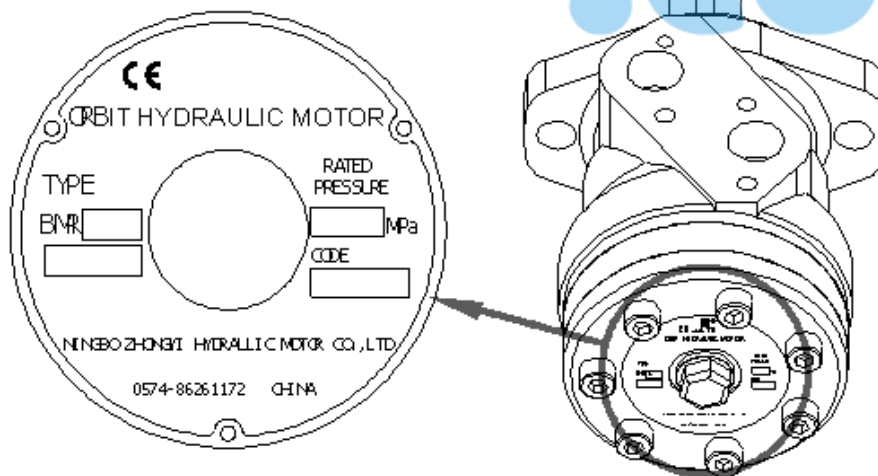

Comment:

The "CODE" on the nameplate includes the information of its manufacture date.

For example,

CODE 507381 indicates it is the 381st motor of this series manufactured in July, 2005.

1.5 STRUCTURES AND OPERATION PRINCIPLE

The structure of the motor is indicated as in the following drawing.

1.5.1 OPERATION PRINCIPLE

The hydraulic oil goes into the ring-shaped groove, which is connected with the oil distribution groove. The hydraulic oil goes through the oil distribution groove and the passage on the shell, then into the working cavity among the cycloid, rotor and the stator. The cycloid rotor is pressed to rotate towards the low-pressure cavity, and rotates and revolves around the center of the roller, and transmits its rotation to the output shaft through the transmission shaft, and output the torque. The output shaft and the cycloid rotor rotate synchronously, so the oil distribution groove continuously finishes the oil distribution and the output shaft continuously rotates. The rotating speed varies with the flux, and the rotation direction of the motor varies with the oil input direction.

1.5.2 OUTPUT TURNING (drawing attached)

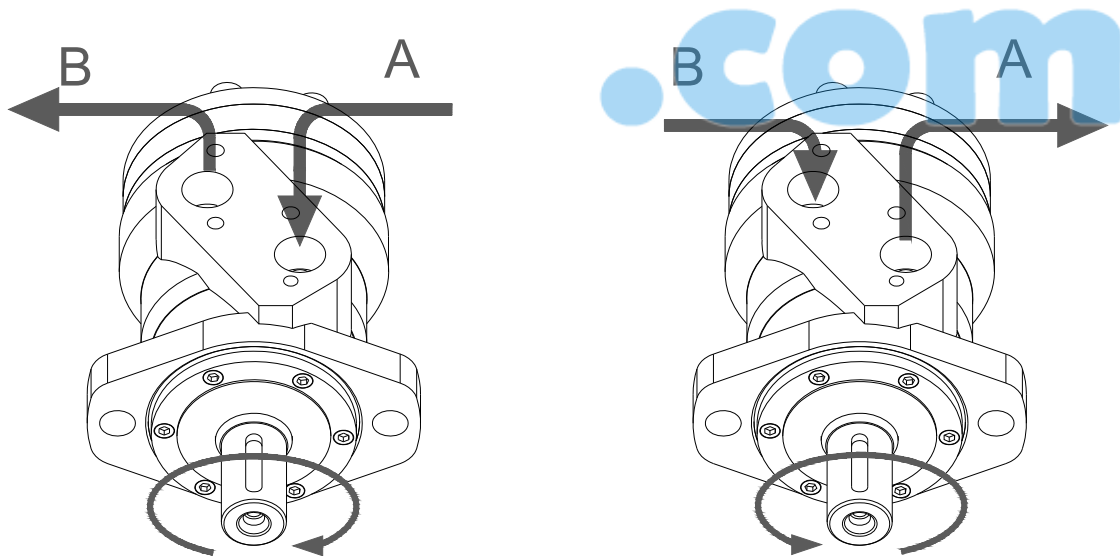

II. WORKING CONDITION

Whether the motor is used correctly will directly influence its working life, so the following basic requirements should be met.

Please read the following items carefully before the installation.

The motor model should be matched with the rotating speed and torque required by the client, and so should the oil pump.

2.1 SYSTEM REQUIREMENTS (drawing attached)

The system should be equipped with corresponding oil filters to ensure the cleanness of the oil used by the system.

The hydraulic circuit must be equipped with a cooling system to prevent excessively high oil temperature.

The oil input pipe should be equipped with pressure meters and thermometers.

The oil circuit for the hydraulic pump should be equipped with pressure meters.

CAUTION

The hydraulic system must be equipped with all the elements indicated in the following chart.

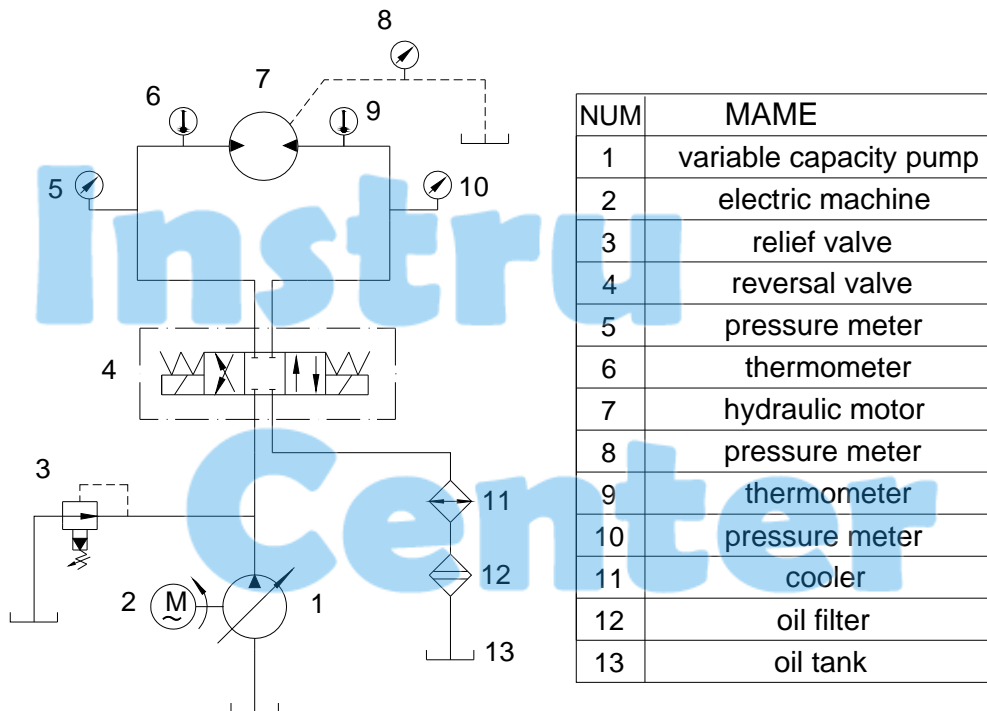

2.2 SYSTEM REQUIREMENTS ABOUT THE HYDRAULIC OIL

According to the environment temperature and different use, the hydraulic oil used should have outstanding viscosity-temperature and anti-foam properties, oxidation and rust resistance, and high flashpoint. During the operation of the motor, its viscosity should be $25 - 70) \times 10^{-6} \text{m}^2/\text{s}$, and the water, alkali and mechanical impurity should not exceed the allowed amount.

YB-N46 and YB-N68 anti-wear hydraulic oil is recommended.

The filter precision of the system should be better than $25\mu\text{m}$.

The normal working temperature is $25-55^\circ\text{C}$. The short-term working temperature should be no higher than 65°C .

2.3 REQUIREMENTS ABOUT THE OIL PIPE

- 1) No. 10 or No. 15 seamless steel pipe should be selected.

2) The size of the oil pipe: $d \geq \sqrt{5.3Q}$ (Q:flux unit: L/min)

3) Thickness (chart attached):

| Pressure P (Mpa) | Thickness δ |
|-----------------------|--------------------|
| $P \leq 8$ | 2 |
| $8 < P \leq 16$ | 3 |
| $16 < P \leq 25$ | 4.5 |

III. INSTALLATION

Before the installation, please check to see whether the motor is damaged. If the motor has been stored for too long, the inner oil should be exhausted and washed to avoid adhesion of the interior moving parts.

The installation bracket for the motor must be of adequate strength, so as to avoid vibration during the rotation

The installation bolts must be evenly tightened.

Connection of the Oil Drain

BMR has two inner check valves, so the leaking oil can return to the oil pipe through the check valves. (Drawing attached)

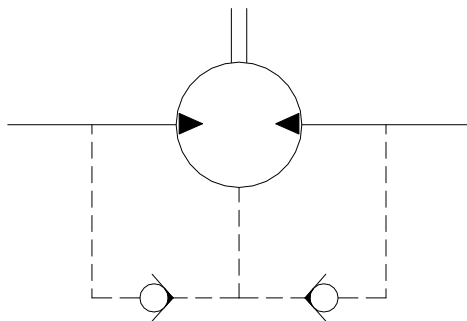

A) When the return oil pressure ≤ 1 Mpa, no oil drain is needed.

B) When the return oil pressure > 1 Mpa, the oil drain must be connected. (drawing

of the location of the oil drain)

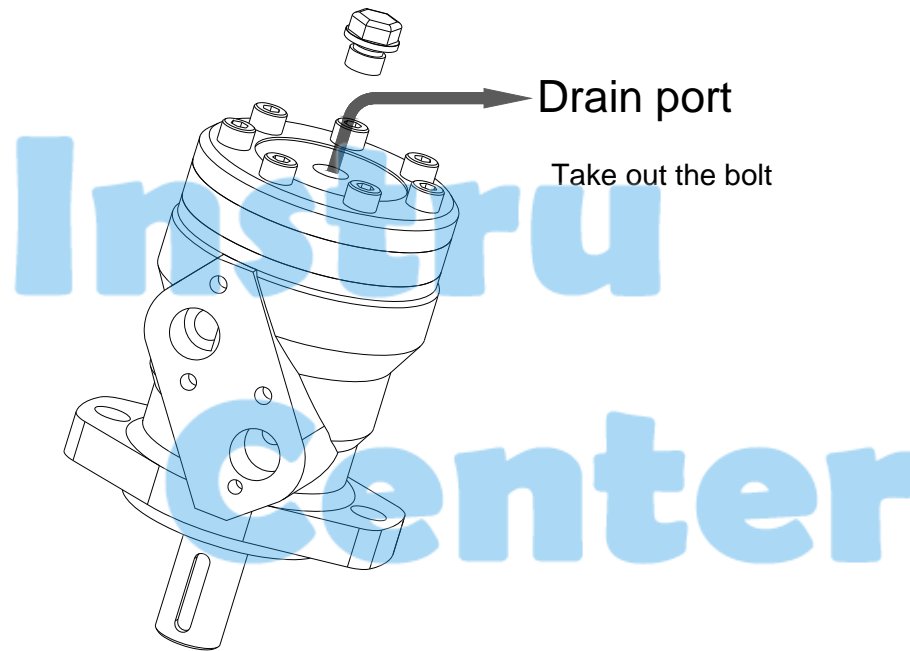

If the motor appears unsteady during low-speed operation, adding the backpressure, which is no less than 0.2 Mpa, can solve it.

This model of motor cannot operate in pump operating condition, less be used as a pump.

The installation surface should be smooth.

Ensure the correct dimension of the connecting flange, mounting and the connecting shaft during the installation.

Ensure the output shaft has a good concentricity with the equipment in connection and transmission with it. During the installation of the output shaft, be careful to prevent axial block between the output shaft and the connecting equipment.

MBR orbit hydraulic motors can bear small radial force.

During the installation, protect the smoothness and parallelism of the connecting panel at the oil output hole, and prevent the bad oil sealing because of bumps, which may lead to leakage.

WARNING

Never knock the rear screws and rear cap of the motor during installation.

If it is necessary to do so, knock the installation flange. (Drawing attached)

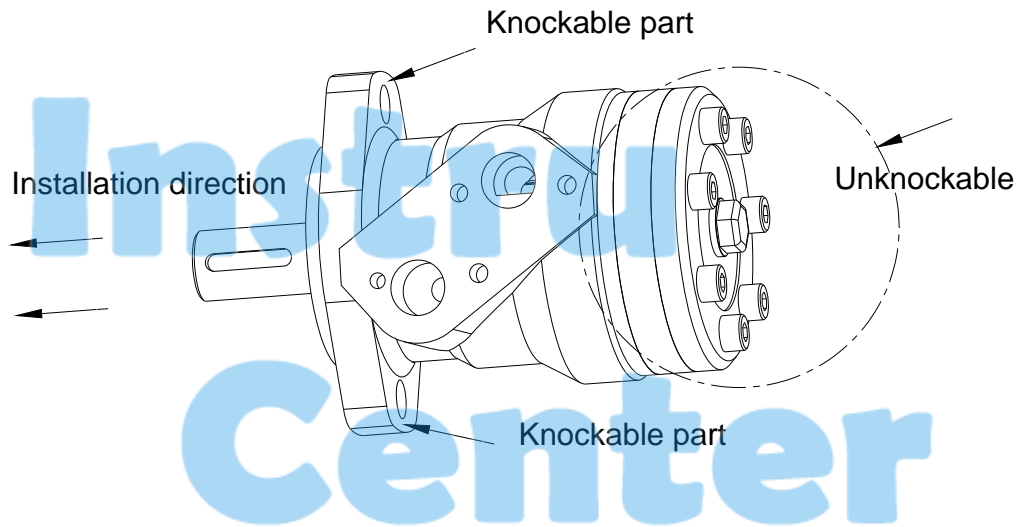

The motor cannot be installed with force or in distortion.

Do not take away the plastic stuff before the pipe circle and the oil pipe are installed.

For system coupling, please notice the relation between the installation location of the oil input/output ports of the motor and the rotation of the motor. During installation, if the oil input/output ports do not correspond with the rotation direction of the output shaft, exchange the oil input/output pipes connection to the A and B cavities, then the working rotation direction will be converse.

IV. USAGE OF THE MOTOR

4.1 USAGE OF THE MOTOR

The pressure, flux and output power of the motor should not exceed the prescribed value.

For long-term operation, the oil temperature should not exceed 65°C.

The maximal working temperature of the motor: -30°C - 70°C

4.2 TRIAL OPERATION

Before starting the motor, check to see whether the motor is correctly installed and connected, whether the connection is correct and fast, and whether the system has no error.

Check to see whether the oil input/output direction and the rotation direction of the motor is in accordance with the operating condition requirements.

Adjust the pressure of the relief valve of the oil supply circuit to the lowest, and gradually

turn it to the demanded pressure in operation.
Tighten the input/output pipe and oil drain.

When the motor has operated with no load for at least 20min, gradually increase the pressure to the working pressure, and notice at any moment whether the motor operates normally.

During the operation, frequently check the working situation of the motor and the system. In case of abnormal temperature rising, leakage, vibration and noise, or abnormal fluctuation of pressure, immediately stop the machine and find out the cause.

CAUTION

motor surface.

During the use of the motor, if the oil input port temperature $\geq 65^{\circ}\text{C}$, please check to see whether the cooler is working normally, to ensure the normal working temperature of the

V. MOVING AND STORAGE

Each motor should be packed individually.

Be careful and gentle during package and transportation, and prevent the motor from bumping with other rigid objects.

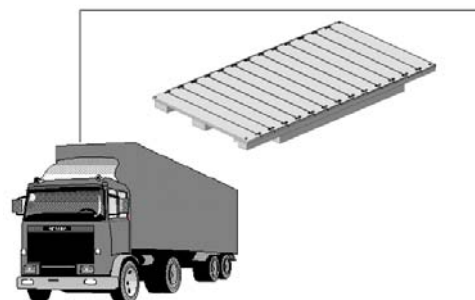

For the transportation, the motor must be equipped with appropriate wooden box and crate according to its size, and it should be wrapped with plastic paper to prevent motor failure because of rust caused by humidity.

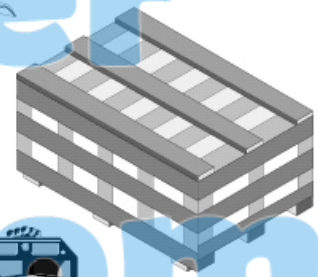
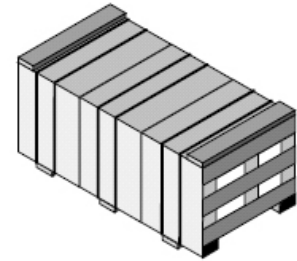

Avoid laying the motor directly on the ground. If unused for a long time, it should be covered with anti-rust oil.



Open the package box and take out the motor as indicated in the drawing.

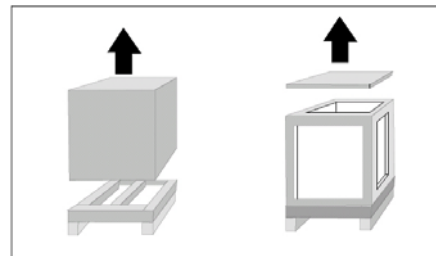

Storage environment: 10—90%RH, -20—65°C.

Avoid vapor, humidity and any corrosive gas during the transportation and storage of the motor.

WARNING

Please do not put the motor in abnormal environment, or the motor will be affected.

VI . SOLUTIONS TO MOTOR FAILURES

The motor is a delicate element, and needs installing, trying and maintaining by professionals. Without the permission of our company, never dismantle and repair it by yourself. With the permission of our company and with the user unit able to dismantle and check it, do it by yourself after reading the instructions, and pay attention to the following three points:

- During the dismantling, do not burr or bump the parts, with special attention to the moving surface and sealing surface. Put the dismantled parts in a clean container and avoid collision between each other. Hammer knocking is prohibited in dismantling and assembling.
- Carefully check the dismantled parts. For the worn parts, basically change them instead of repairing them. In principle, the sealing parts should all be changed.
- Before assembling, wash and dry all the parts, and do not mop the parts with cotton yarn and rag. The assembling environment and the tools used should be clean. After the assembling, turn the output shaft and ensure it is flexible and not blocked.

Instru Center

SOLUTIONS TO FAILURES

| NO. | Failure | Cause | Solution |
|-----|-------------------------------------|---|--|
| 1 | The motor does not rotate. | The hydraulic pump not started | Start the hydraulic pump |
| | | Inadequate oil in the oil tank | Fill in the oil |
| | | The reversal valve in the middle | Open the reversal valve |
| | | The system relief valve fully open | Adjust the system pressure to the prescribed value |
| | | Inadequate motor torque | Change the motor |
| 2 | Abnormal noise during the operation | Air in the hydraulic system | Find out the cause of air inlet and exhaust the air in the oil |
| | | Empty oil tank | Increase oil supply |
| | | Motor failure | Change the motor |
| | | Damaged support bearing | Change the bearing |
| 3 | Motor leakage | Damaged seal | Change the seal |
| | | Air hole, sand hole or crack on the parts | Change the parts |
| 4 | Motor heating | Excessive temperature of the hydraulic oil | Increase the cooling capacity |
| | | Low efficiency of the motor | Change the wear parts |
| | | Abnormal wear | Change the motor |
| 5 | Increased leakage at the spill port | Abnormal wear of the oil distribution panel | Rub the oil distribution panel, rub the flow |

| | | | |
|--|--|------------------------------------|---|
| | | Seal damage at the plain or piston | distribution plain of the shell and change the seal |
|--|--|------------------------------------|---|

Instru

VII. MAINTENANCE AND LATER DISPOSAL

Maintenance:

Duly check the fittings of the hydraulic system, the accuracy of the pressure meter and the thermometer.

Duly check the hydraulic oil:

It is prohibited to use blend oil of different types of hydraulic oils. The period of changing the oil varies with different mines.

In general case: change the hydraulic oil every half a year.

Disposal of the waste oil after using the motor:

It should be carried to the waste oil disposal unit for central disposal.

If the motor is to be unused for a long time:

The cavity should be filled with oil and each oil hole should be sealed with oil. Cover the output shaft with lubrication, and wrap it with cloth or a cover.

WARNING: FOR THE CONSEQUENCES CAUSED BY THE USER BECAUSE HE DOES NOT OBEY THE ABOVE SUGGESTION OR USES THE MOTOR IN A WRONG WAY, THE COMPANY DOES NOT BEAR ANY RESPONSIBILITY.

I. BRIEF INTRODUCTION

1.1 APPLICATION SCOPE

This series of motor, with its shell made of ductile cast iron of adequate intensity, can be applied to low-speed heavy-load gearing, widely to equipment of agriculture, machine tools, injection molding, crane charging and drawing, mining and construction machines, such as the tread and slew drive of the hydraulic digger, the drive for the machine tool's principal shaft and feeding mechanism, the pre-molding screw drive of the injection molding machine, the winch drive, the drive for various conveyors, and the hydraulic traction drive of coal cutters.

1.2 MAIN CHARACTERISTICS (drawing attached)

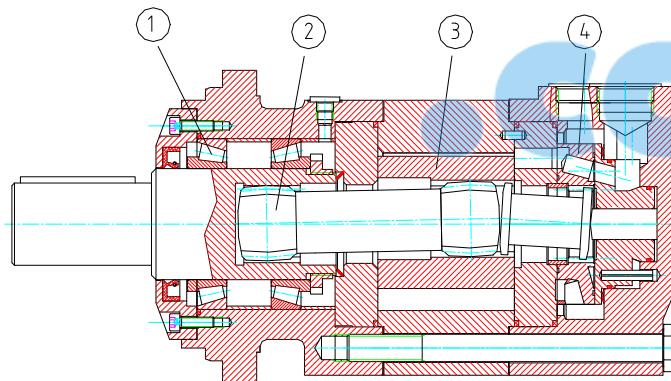

- 1) The output shaft, supported by two taper roller bearings, can bear great radial force and axial force.
- 2) The transmission shaft, with involute spline, is reliable.
- 3) The cycloid group, composed of the stator, the cycloid rotor and roller, has a small friction and high mechanical efficiency.
- 4) With the plain bottom distributor structure and a high volumetric efficiency.

1.3 MAIN SPECIFICATIONS AND BASIC PARAMETERS

BMS, BMS S technical parameter

| Type BM3-/BM3S- | Rated pressure (Mpa) | Speed range (r/min) | Max output power (Kw) | Weight (Kg) | Rated torque (N·M) | L (mm) |
|--------------------|---------------------------|--------------------------|-------------------------------|------------------|-------------------------|-----------|
| 80 | 16 | 10-810 | 14 | 9.8 | 175 | 167/127 |
| 100 | 16 | 10-750 | 16 | 10.0 | 215 | 170/131 |
| 125 | 16 | 9-600 | 16 | 10.3 | 270 | 175/135 |
| 160 | 14 | 7-470 | 14 | 10.7 | 300 | 181/141 |
| 200 | 14 | 6-375 | 14 | 11.1 | 378 | 188/148 |
| 250 | 11 | 6-300 | 11 | 11.6 | 380 | 197/157 |
| 315 | 10 | 5-240 | 10 | 12.3 | 425 | 208/169 |

BMS/BMS INSTALLATION

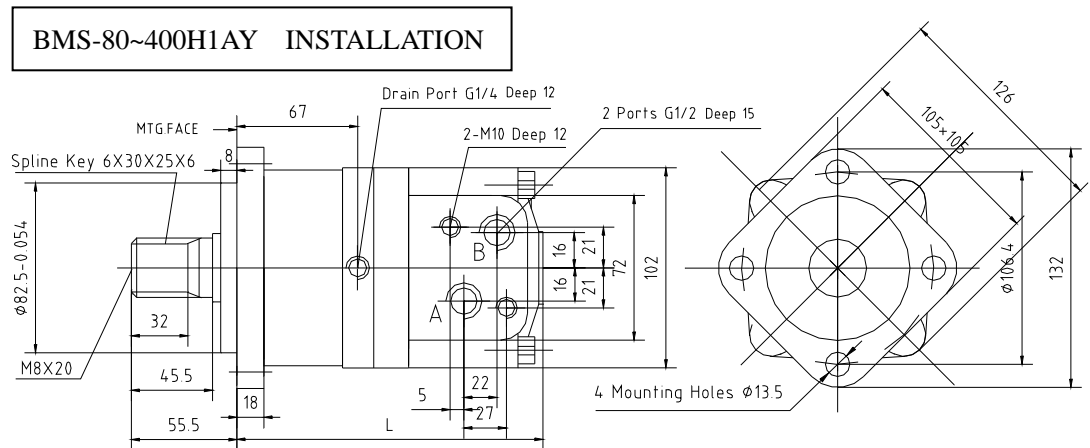

BMS-80~400PAIYY INSTALLATION

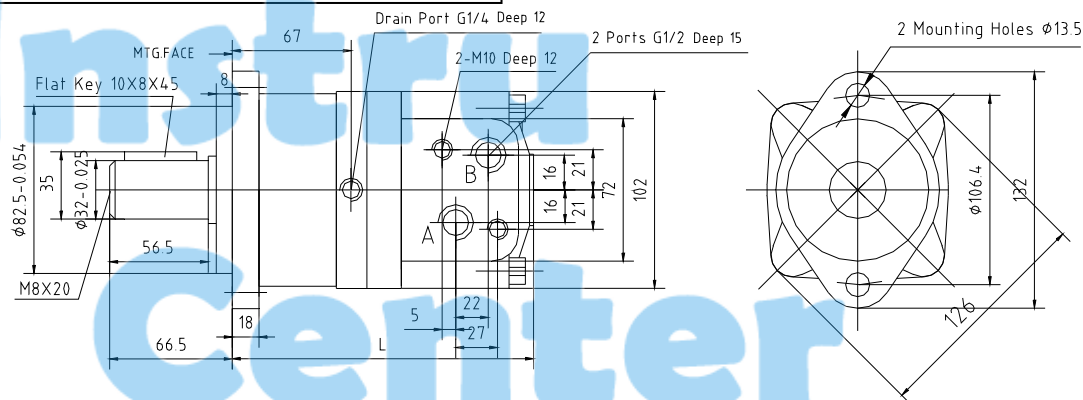

BMS-80~400H1AIYY INSTALLATION

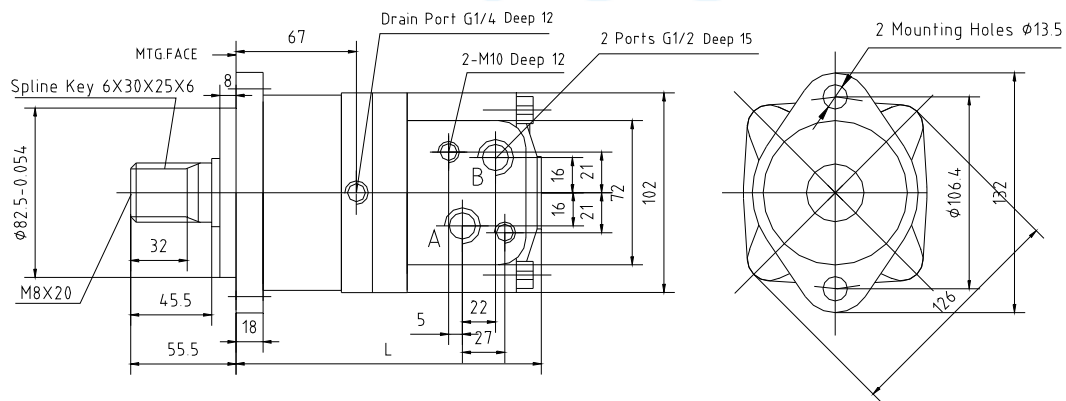

BMS-80~400PAIVY INSTALLATION

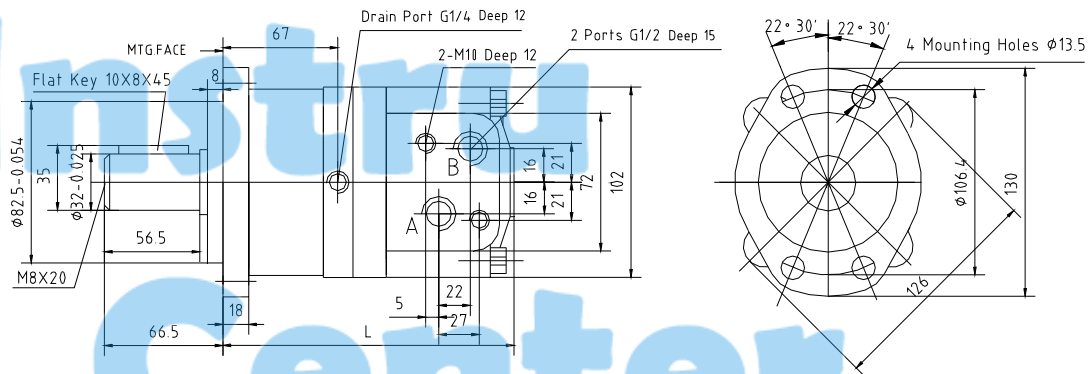

BMS-80~400 H1AIVY INSTALLATION

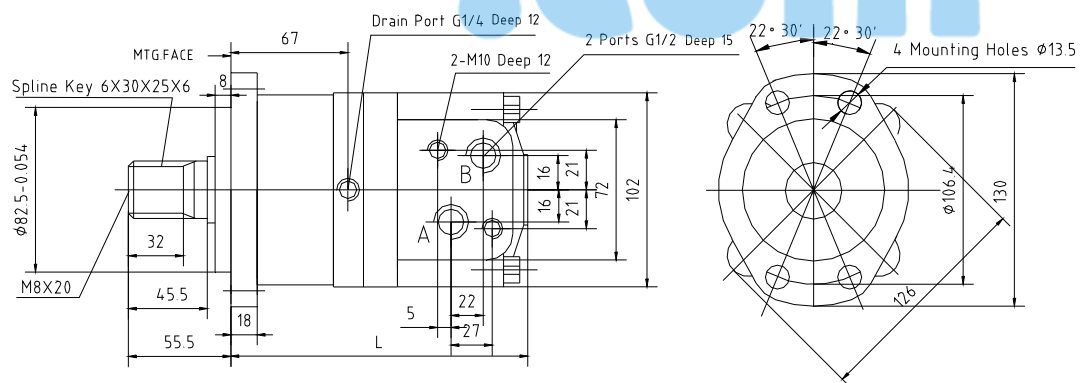

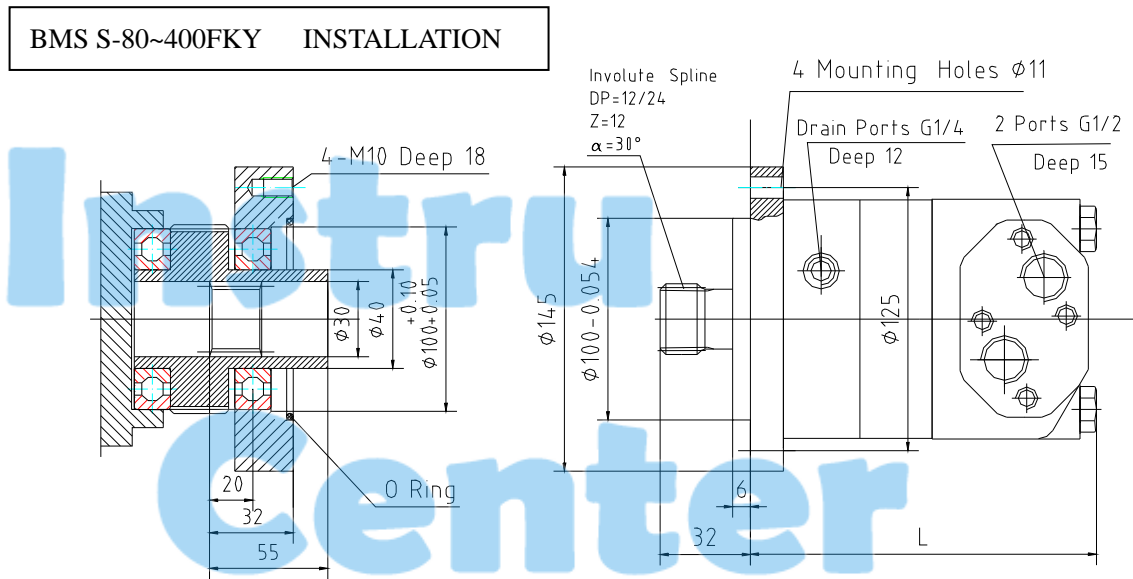

BMS, BMSS technical parameter

| Type BMS-/BMSS - | Rated pressure (Mpa) | Speed range (r/min) | Max output power (Kw) | Weight (Kg) | Rated torque (N-M) | L (mm) |
|------------------------|---------------------------|--------------------------|----------------------------|------------------|-------------------------|-----------|
| 160 | 16 | 10-625 | 20.1 | 20.3 | 408 | 210/150 |
| 200 | 16 | 9-625 | 25.2 | 20.8 | 504 | 215/155 |
| 250 | 16 | 8-500 | 25.2 | 21.4 | 630 | 220/161 |
| 320 | 14 | 7-380 | 25.2 | 22.4 | 807 | 227/170 |
| 400 | 14 | 6-305 | 22 | 23 | 896 | 228/181 |

BMS, BMSS INSTALLATION

BHC ORBIT Hydraulic motors

BMS series Manual

BMS -160~500PAY INSTALLATION

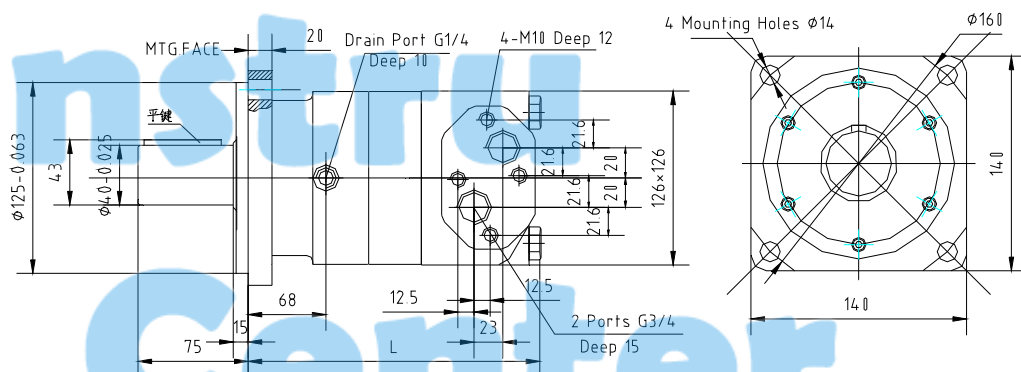

BMS -160~500K6AY INSTALLATION

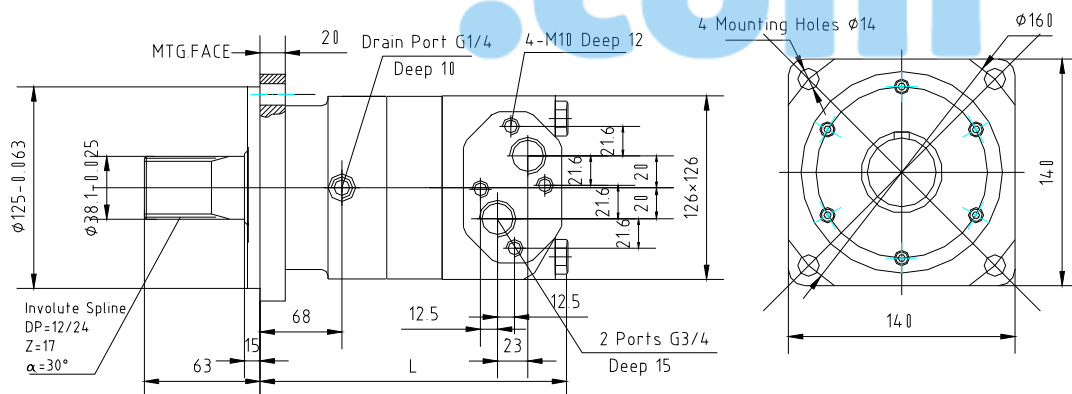

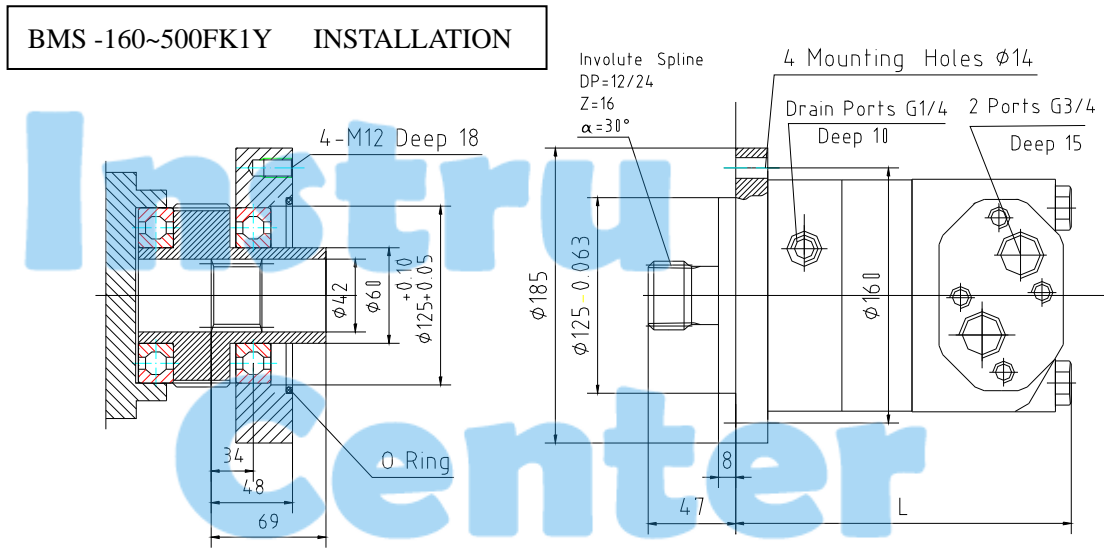

.com

BMS, BMSS technical parameter

| Type BMS-/BMSS- | Rated pressure (Mpa) | Speed range (r/min) | Max output power (Kw) | Weight (Kg) | Rated torque (N·M) | L (mm) |
|--------------------|---------------------------|--------------------------|----------------------------|------------------|-------------------------|-------------|
| 315 | 18 | 10-630 | 32 | 30.7 | 785 | 211/175 |
| 400 | 18 | 9-500 | 40 | 31.5 | 992 | 218/182 |
| 500 | 18 | 8-400 | 40 | 32.4 | 1236 | 226/190 |
| 630 | 18 | 6-315 | 40 | 33.6 | 1558 | 237/201 |
| 800 | 16 | 5-250 | 35 | 35.2 | 1766 | 251/215 |

BMS, BMSS INSTALLATION

BMS -315~985PAY INSTALLATION

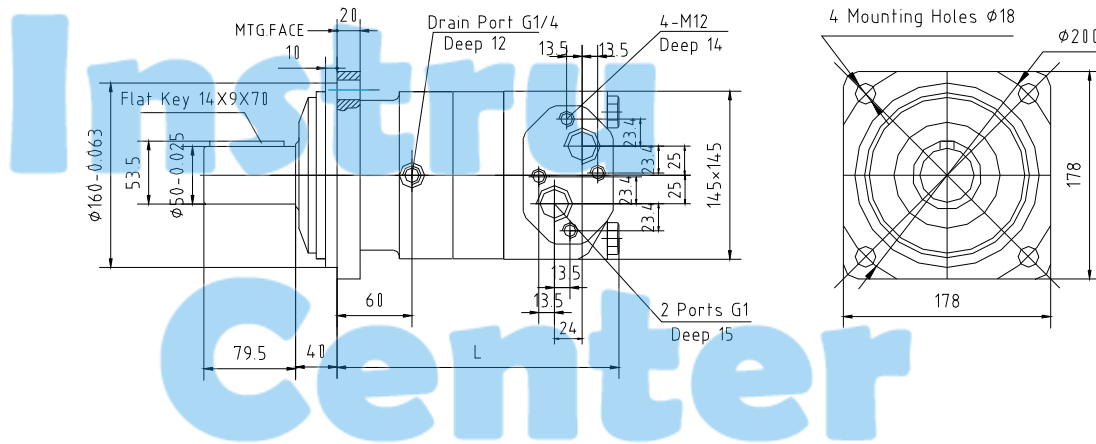

BMS -315~985K3AY INSTALLATION

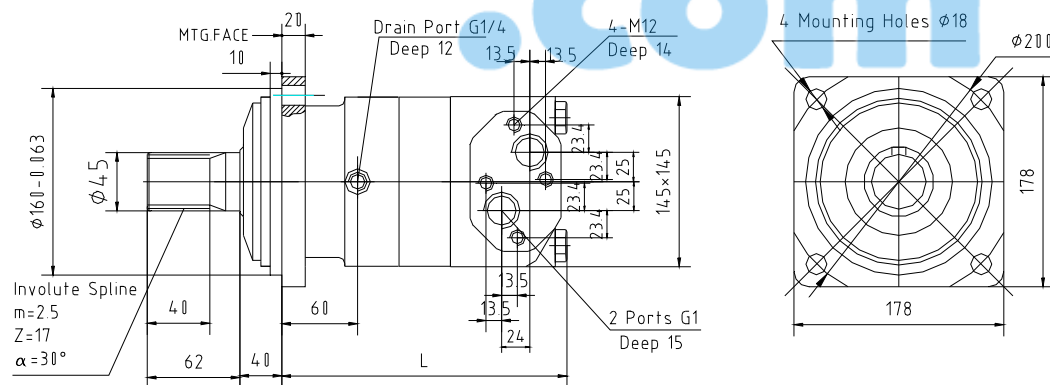

BMS -315~985FKY INSTALLATION

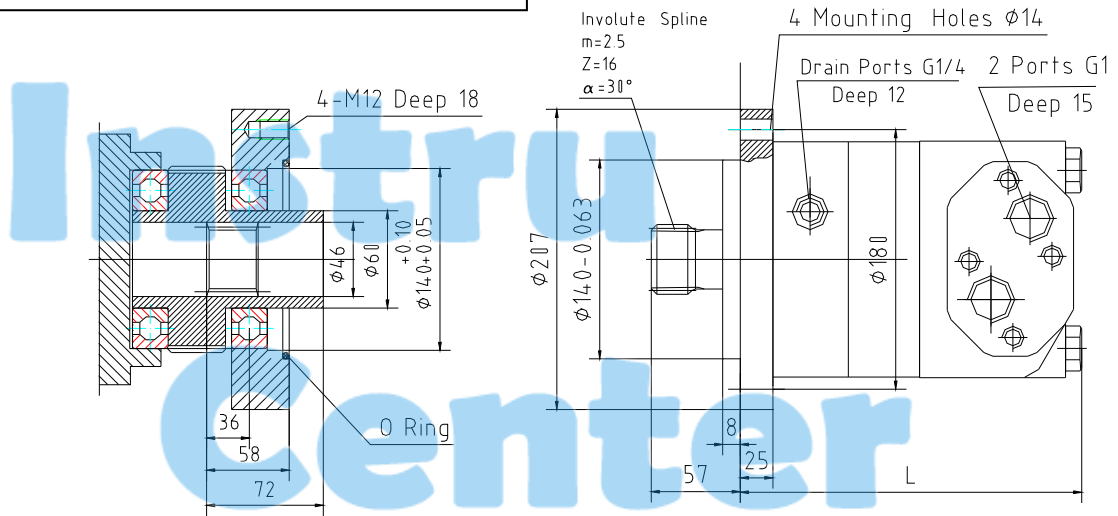

.com

1.4 NAMEPLATE (drawing attached): nameplate location and the drawing of the nameplate

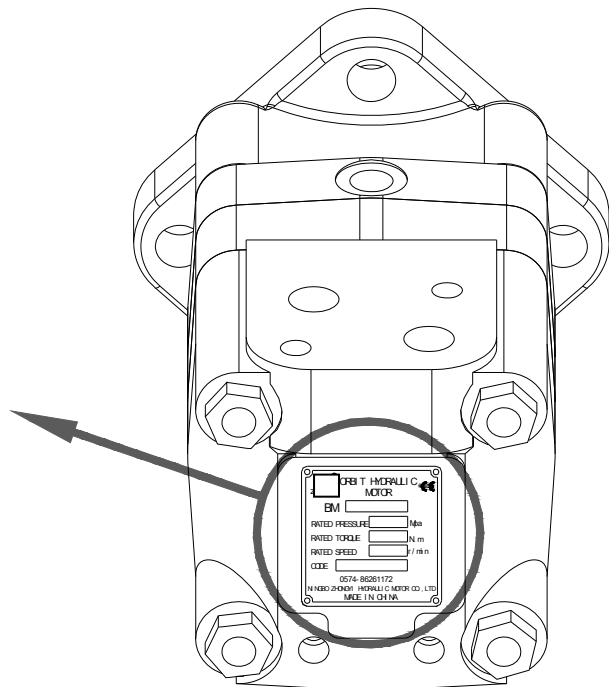
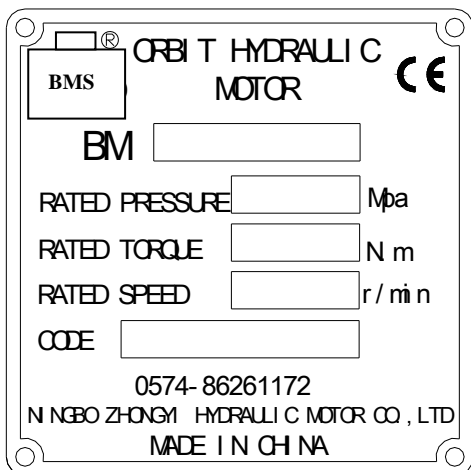

Comment:

The "CODE" on the nameplate includes the information of its manufacture date.

For example,

CODE 507381 indicates it is the 381st motor of this series manufactured in July, 2005.

1.5 STRUCTURES AND OPERATION PRINCIPLE

The structure of the motor is indicated as in the following drawing.

1.5.1 OPERATION PRINCIPLE

The hydraulic oil goes into the rear shell through the oil hole, then into the working cavity between the cycloid rotor and roller through the bracket panel, flow distribution valve and the rear lateral plate. Under the oil pressure, the cycloid rotor is pressed to rotate towards the low-pressure cavity. It rotates and revolves around the center of the roller, and transmits its rotation to the output shaft through the transmission shaft. Meanwhile, through the distribution shaft, it makes the distribution valve rotate synchronically to achieve the continuous flow distribution and the continuous rotation of the output shaft. The rotating speed varies with the flux.

1.5.2 OUTPUT TURNING (drawing attached)

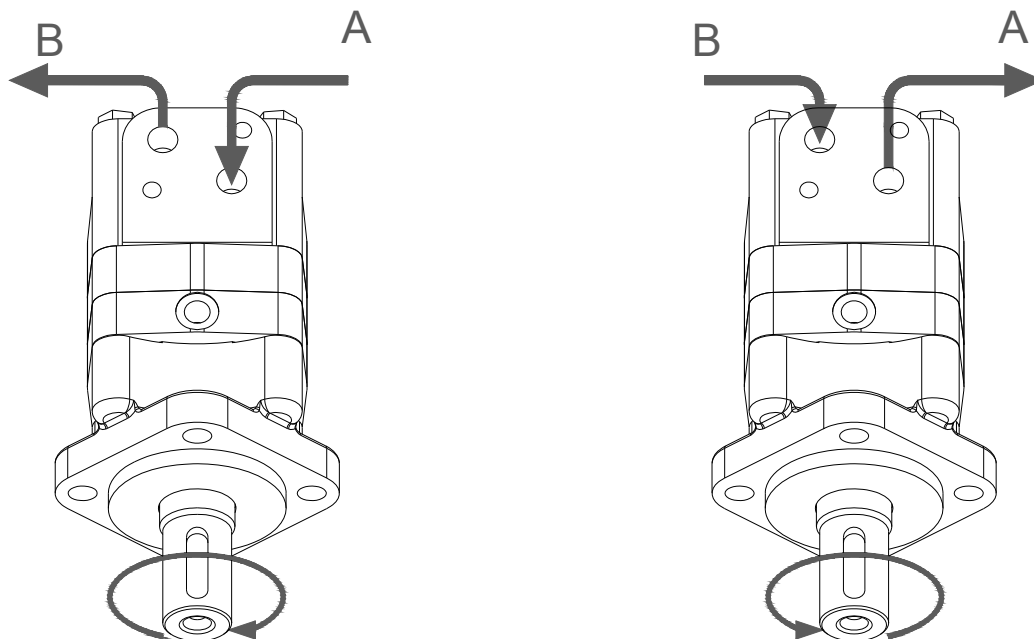

II. WORKING CONDITION

Whether the motor is used correctly will directly influence its working life, so the following basic requirements should be met.

Please read the following items carefully before the installation.

The motor model should be matched with the rotating speed and torque required by the client, and so should the oil pump.

2.1 SYSTEM REQUIREMENTS (drawing attached)

The system should be equipped with corresponding oil filters to ensure the cleanness of the oil used by the system.

The hydraulic circuit must be equipped with a cooling system to prevent excessively high oil temperature.

The oil input pipe should be equipped with pressure meters and thermometers.

The oil circuit for the hydraulic pump should be equipped with pressure meters.

CAUTION

The hydraulic system must be equipped with all the elements indicated in the following chart.

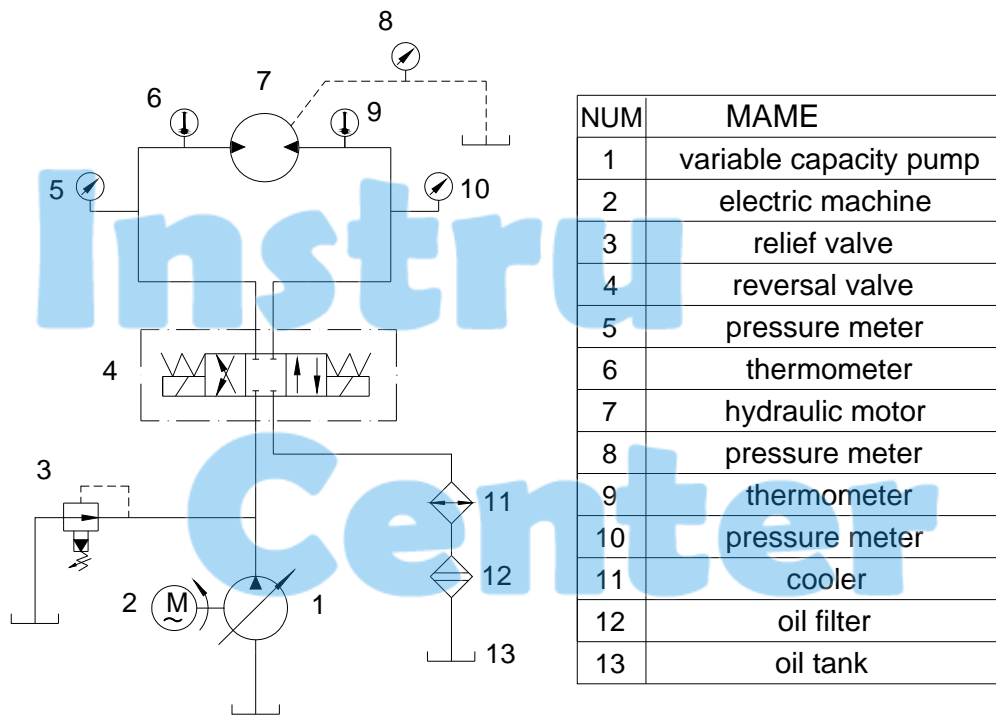

2.2 SYSTEM REQUIREMENTS ABOUT THE HYDRAULIC OIL

According to the environment temperature and different use, the hydraulic oil used should have outstanding viscosity-temperature and anti-foam properties, oxidation and rust resistance, and high flashpoint. During the operation of the motor, its viscosity should be $25 - 70) \times 10^{-6} \text{m}^2/\text{s}$, and the water, alkali and mechanical impurity should not exceed the allowed amount.

YB-N46 and YB-N68 anti-wear hydraulic oil is recommended.

The filter precision of the system should be better than $25\mu\text{m}$.

The normal working temperature is $25-55^\circ\text{C}$. The short-term working temperature should be no higher than 65°C .

2.3 REQUIREMENTS ABOUT THE OIL PIPE

- 1) No. 10 or No. 15 seamless steel pipe should be selected.
- 2) The size of the oil pipe: $d \geq \sqrt{5.3Q}$ (Q:flux unit: L/min)
- 3) Thickness (chart attached):

| Pressure P (Mpa) | Thickness δ |
|-----------------------|--------------------|
| $P \leq 8$ | 2 |
| $8 < P \leq 16$ | 3 |
| $16 < P \leq 25$ | 4.5 |

Instru
Center
.com

III. INSTALLATION

Before the installation, please check to see whether the motor is damaged. If the motor has been stored for too long, the inner oil should be exhausted and washed to avoid adhesion of the interior moving parts.

The installation bracket for the motor must be of adequate strength, so as to avoid vibration during the rotation

The installation bolts must be evenly tightened.

CONNECTION OF THE OIL DRAIN

- 1) BM3 has two inner check valves, so the leaking oil can return to the oil pipe through the check valves. (Drawing attached)

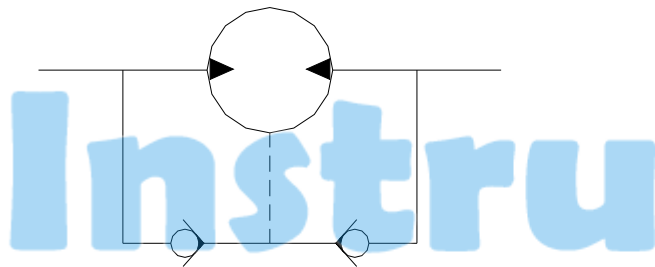

- A) When the return oil pressure ≤ 1 Mpa, no oil drain is needed.
- B) When the return oil pressure > 1 Mpa, the oil drain must be connected. (drawing of the location of the oil drain)
- 2) For BM4, BM5 and BM6, the oil drain must be connected.

The locations of the oil drains for BM3, BM4, BM5 and BM6 are indicated as in the drawing:

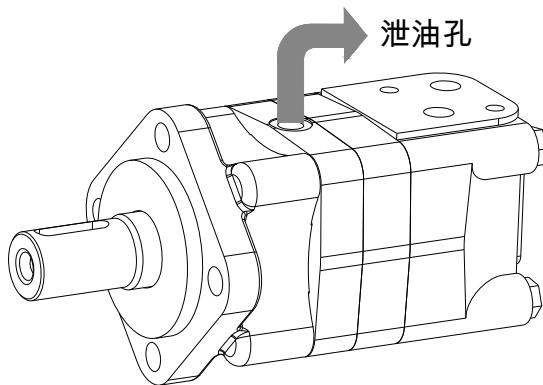

If the motor appears unsteady during low-speed operation, adding the backpressure, which is no less than 0.2 Mpa, can solve it.

This type of motor cannot operate in pump operating condition, less be used as a pump.

The installation surface should be smooth.

Ensure the correct dimension of the connecting flange, mounting and the connecting shaft during the installation.

Ensure the output shaft has a good concentricity with the equipment in connection and transmission with it. During the installation of the output shaft, be careful to prevent axial block between the output shaft and the connecting equipment.

During the installation, protect the smoothness and parallelism of the connecting panel at

the oil output port, and prevent the bad oil sealing because of bumps, which may lead to leakage.

The location of the hook is indicated as in the drawing.

CAUTION

To ensure the safe craning, please use crane of adequate size and adequate hooks and ropes. For the corresponding motor weight, please refer to the basic parameter table.

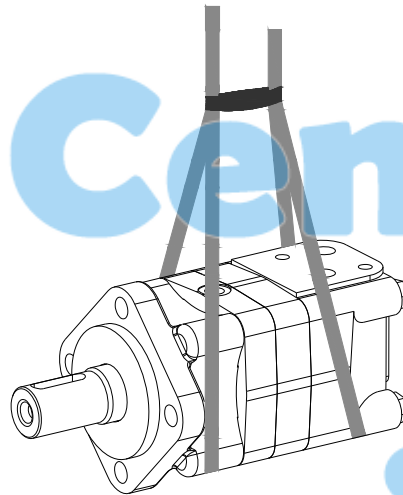

The motor cannot be installed with force or in distortion.

Do not take away the plastic stuff before the pipe circle and the oil pipe are installed.

For system coupling, please notice the relation between the installation location of the oil input/output ports of the motor and the rotation of the motor. During installation, if the oil input/output ports do not correspond with the rotation direction of the output shaft, exchange the oil input/output pipes connection to the A and B cavities, then the working rotation direction will be converse.

IV. USAGE OF THE MOTOR

4.1 USAGE OF THE MOTOR

The pressure, flux and output power of the motor should not exceed the prescribed value.

For long-term operation, the oil temperature should not exceed 65°C.

The maximal working temperature of the motor: -30°C - 70°C

4.2 TRIAL OPERATION

Before starting the motor, check to see whether the motor is correctly installed and connected, whether the connection is correct and fast, and whether the system has no error.

Check to see whether the oil input/output direction and the rotation direction of the motor is in accordance with the operating condition requirements.

Adjust the pressure of the relief valve of the oil supply circuit to the lowest, and gradually turn it to the demanded pressure in operation.

Tighten the input/output pipe and oil drain.

When the motor has operated with no load for at least 20min, gradually increase the pressure to the working pressure, and notice at any moment whether the motor operates normally.

During the operation, frequently check the working situation of the motor and the system. In case of abnormal temperature rising, leakage, vibration and noise, or abnormal fluctuation of pressure, immediately stop the machine and find out the cause.

CAUTION

During the use of the motor, if the oil input hole temperature $\geq 65^{\circ}\text{C}$, please check to see whether the cooler is working normally, to ensure the normal working temperature of the motor surface.

V. MOVING AND STORAGE

Each motor should be packed individually.

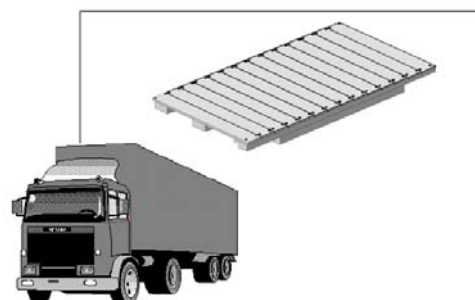

BHC ORBIT Hydraulic motors**BMS** series Manual

Be careful and gentle during package and transportation, and prevent the motor from bumping with other rigid objects.

Instru



For the transportation, the motor must be equipped with appropriate wooden box and crate according to its size, and it should be wrapped with plastic paper to prevent motor failure because of rust caused by humidity.

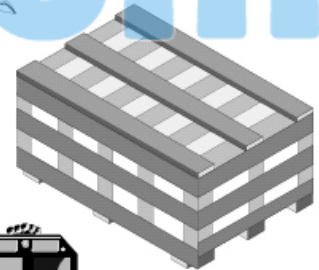
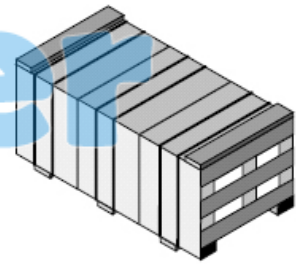

Avoid laying the motor directly on the ground. If unused for a long time, it should be covered with anti-rust oil.



Open the package box and take out the motor as indicated in the drawing.

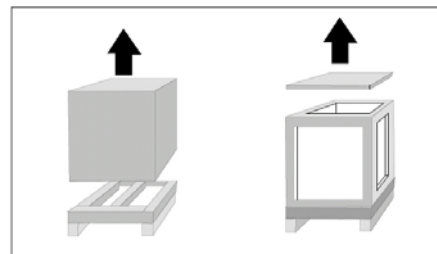



Storage environment: 10—90%RH, -20—65°C.

Avoid vapor, humidity and any corrosive gas during the transportation and storage of the motor.

Instru

WARNING

Please do not put the motor in abnormal environment, or the motor will be affected.

Center

.com

VI . SOLUTIONS TO MOTOR FAILURES

The motor is a delicate element, and needs installing, trying and maintaining by professionals. Without the permission of our company, never dismantle and repair it by yourself. With the permission of our company and with the user unit able to dismantle and check it, do it by yourself after reading the instructions, and pay attention to the following three points:

- During the dismantling, do not burr or bump the parts, with special attention to the

moving surface and sealing surface. Put the dismantled parts in a clean container and avoid collision between each other. Hammer knocking is prohibited in dismantling and assembling.

- Carefully check the dismantled parts. For the worn parts, basically change them instead of repairing them. In principle, the sealing parts should all be changed.
- Before assembling, wash and dry all the parts, and do not mop the parts with cotton yarn and rag. The assembling environment and the tools used should be clean. After the assembling, turn the output shaft and ensure it is flexible and not blocked.

SOLUTIONS TO FAILURES

| NO. | Failure | Cause | Solution |
|-----|-------------------------------------|---|--|
| 1 | The motor does not rotate. | The hydraulic pump not started | Start the hydraulic pump |
| | | Inadequate oil in the oil tank | Fill in the oil |
| | | The reversal valve in the middle | Open the reversal valve |
| | | The system relief valve fully open | Adjust the system pressure to the prescribed value |
| | | Inadequate motor torque | Change the motor |
| 2 | Abnormal noise during the operation | Air in the hydraulic system | Find out the cause of air inlet and exhaust the air in the oil |
| | | Empty oil tank | Increase oil supply |
| | | Motor failure | Change the motor |
| | | Damaged support bearing | Change the bearing |
| 3 | Motor leakage | Damaged seal | Change the seal |
| | | Air hole, sand hole or crack on the parts | Change the parts |
| 4 | Motor heating | Excessive temperature of the hydraulic oil | Increase the cooling capacity |
| | | Low efficiency of the motor | Change the wear parts |
| | | Abnormal wear | Change the motor |
| 5 | Increased leakage at the spill port | Abnormal wear of the oil distribution panel | Rub the oil distribution panel, rub the flow |

BHC ORBIT Hydraulic motors

BMS series Manual

| | | | |
|--|--|------------------------------------|---|
| | | Seal damage at the plain or piston | distribution plain of the shell and change the seal |
|--|--|------------------------------------|---|

Instru

VII. MAINTENANCE AND LATER DISPOSAL

Center

Maintenance:

Duly check the fittings of the hydraulic system, the accuracy of the pressure meter and the thermometer.

Duly check the hydraulic oil:

It is prohibited to use blend oil of different types of hydraulic oils. The period of changing the oil varies with different mines.

In general case: change the hydraulic oil every half a year.

.com

Disposal of the waste oil after using the motor:

It should be carried to the waste oil disposal unit for central disposal.

If the motor is to be unused for a long time:

The cavity should be filled with oil and each oil hole should be sealed with oil. Cover the output shaft with lubrication, and wrap it with cloth or a cover.

WARNING: FOR THE CONSEQUENCES CAUSED BY THE USER BECAUSE HE DOES NOT OBEY THE ABOVE SUGGESTION OR USES THE MOTOR IN A WRONG WAY, THE COMPANY DOES NOT BEAR ANY RESPONSIBILITY.