

Rexport

**Direct operated pressure reducing valve,  
sandwich plate,type ZDR 10D...50B/(New Series)**

RE26585/12.2004

Size 10

up to 21MPa

up to 80L/min

**Features:**

- Sandwich plate design
- Pressure reduction in ports A, B or P
- 4 adjustment elements:
  - Rotary knob
  - Hex. head screw with protective cap
  - Lockable rotary knob with scale
  - Rotary knob with scale
- 4 pressure ratings
- optional check valve
- Porting pattern to DIN 24 340, form A,ISO 4401 and CETOP-RP 121H

**Functional, section**

The pressure reducing valve type ZDR 10 D.. is a 3-way direct operated valve of sandwich plate design with a pressure relief function on the secondary side. It is used to reduce the system pressure.

The pressure reducing valve basically consists of the housing (1), the control spool (2), a compression spring (3),and the adjustment (4) as well as an optional check valve.

The secondary pressure is set by the pressure adjustment element (4). Model "DA"

At rest, the valve is normally open, and fluid can flow unhindered from port A1 to port A2. The pressure in port A2 is at the same time via the control line (5) present at the spool area opposite to the compression spring (3). When the pressure in port A2 exceeds the pressure level set at the compression spring (3), the control spool (2) moves into the control position against the compression spring (3) and holds the set pressure in port A2 constant.

The control pressure and pilot oil are taken from port A2 via control line (5).

If the pressure in port A2 rises still further due to external forces, the control spool (2) is moved still further towards the compression spring (3).

This causes a flow path to be opened at port A2 via control land (5) on the control spool (2) and housing (1) to tank (port TB). Sufficient fluid then flows to tank to prevent any further rise in pressure.

The spring chamber (7) is always drained to tank externally via port TA .

A pressure gauge connection (8) permits the secondary pressure at the valve to be monitored.

It is only possible to fit a check valve for free flow in ports A2 to A1 in version "DA".

Models "DP" and "DB"

In model "DP", the pressure is reduced in port P1. The control pressure and the pilot oil is taken internally from port P1.

In model "DB", the pressure in port P1 is reduced, and the pilot oil taken from port B.

Attention!

When the directional valve is in the switched position P to A, pressure in port B must not exceed the set secondary pressure.

Otherwise, pressure in port A will be reduced.

If used without a directional valve, TA and TB must be interconnected (e.g. in the cover plate).

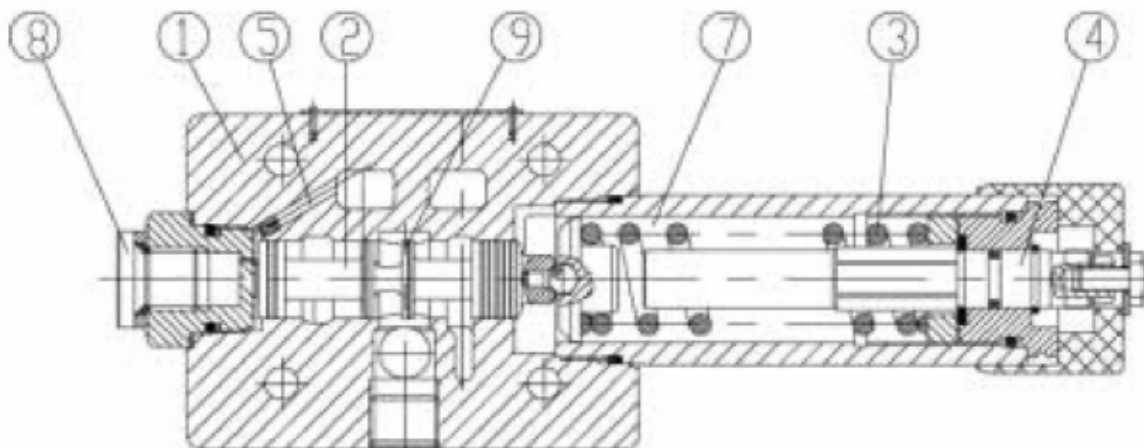

ZDR10DB1-50B/...YM

**Symbols** (① =valve side , ② =subplate side)

ZDR10DP...-50B/...YM...

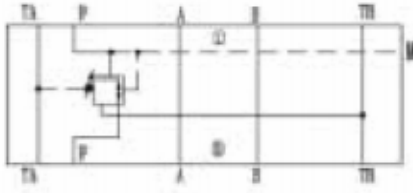

ZDR10DA...-50B/...YM...

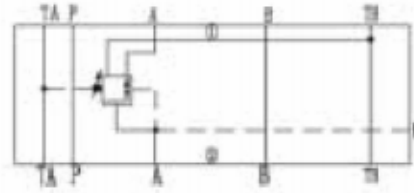

ZDR10DB...-50B/...YM...

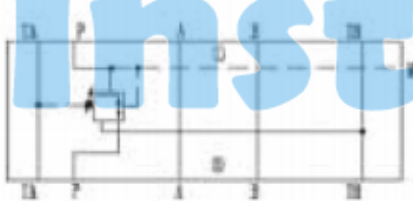

ZDR10DA...-50B/...Y...

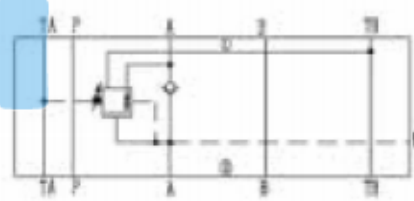

**Ordering details**

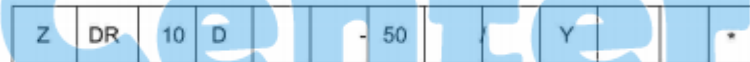

Sandwich plate design = Z	Further details in clear text
Pressure reducing valve = DR	No code. = mineral oils V = phosphate ester
Size 10 = 10	No code. = with check valve (only possible for pressure reduction in port A) M = without check valve
Direct operated = D	Y = Pilot oil feed internal, drain external
Pressure reduction in port A = A	
Pressure reduction in port B = B	
(Pilot oil from port B)	
Pressure reduction in port P = P	
Setting elements	
Rotary knob = 1	
Hex. head screw with protective cap = 2	
Lockable rotary knob with scale = 3	
Rotary knob with scale = 7	
Series 50 to 59 = 50 (50 to 59 = unchanged installation and connection dimensions)	25= max. secondary pressure 2.5 MPa 75= max. secondary pressure 7.5 MPa 150= max. secondary pressure 15.0 MPa 210= max. secondary pressure 21.0 MPa

**Technical data**

Weight	(kg)	approx. 2.8
Pressure fluid		Mineral oil (for NBR seal) or phosphate ester (for FPM seal)
Pressure fluid-temperature range <sup>3</sup>	(°C)	-30 to +80
Viscosity range	(mm <sup>2</sup> /s)	10 to 800
Degree of fluid contamination		recommend a filter with a minimum retention rate of $\beta_{10} \geq 75$
Max. operating Pressure (inlet)	(MPa)	up to 31.5
Secondary pressure (output)	(MPa)	up to 2.5, up to 7.5, up to 15.0, up to 21.0
Back pressure port	(MPa)	up to 16.0
Max. flow	(L/min)	80

**Characteristic curves** (measured at  $v = 41\text{mm}^2/\text{s}$  and  $t = 50^\circ\text{C}$ )

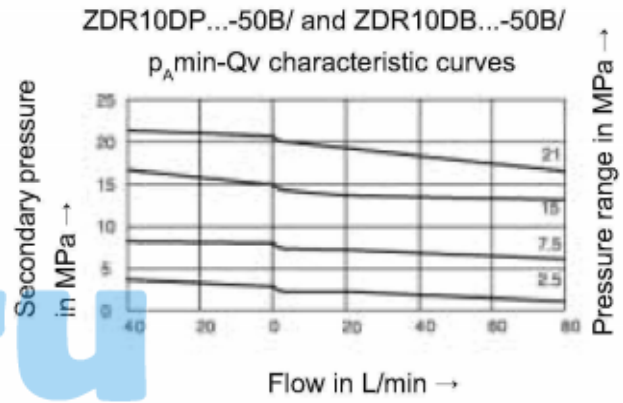
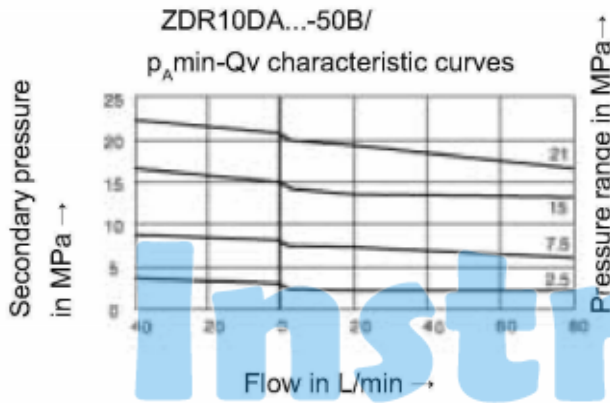

InstruCenter

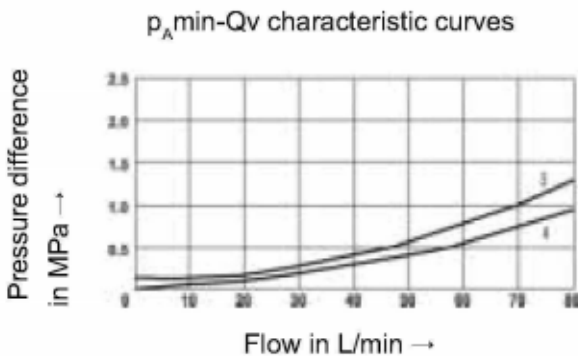
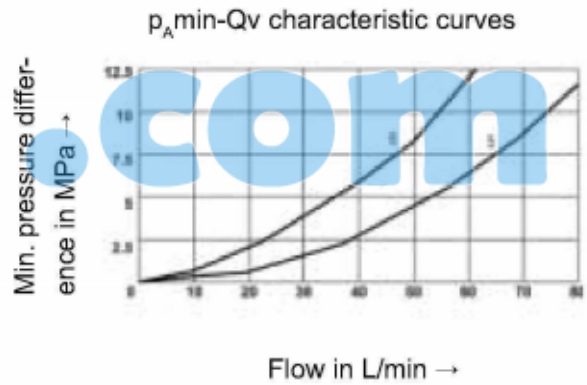
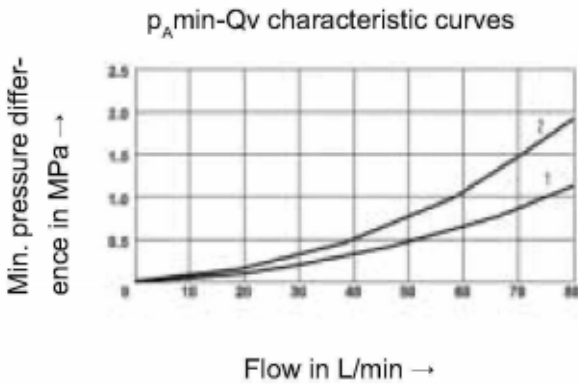

1. A1 to A2
2. A2 to TB (3rd. flow path)
3. A2 to A1(flow via check valve only)
4. A2 to A1(check valve and fully open control cross section)
5. P2 to TB
6. P1 to TB (3rd. flow path)

The characteristic curves for the pressure relief function are valid for the outlet pressure = zero over the entire flow range!

Unit dimensions

(Dimensions in mm)

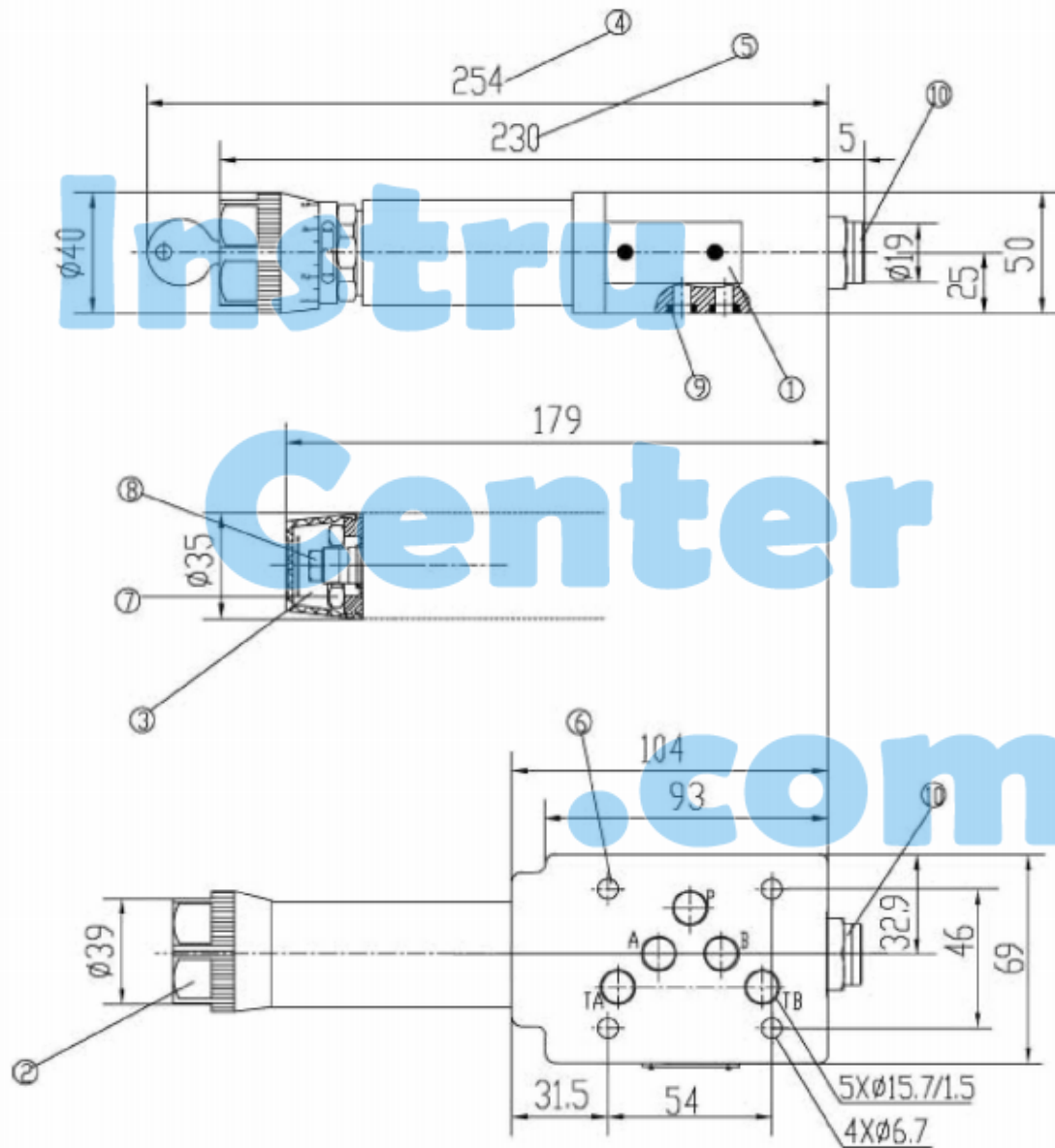

- 1. Nameplate
- 2. Adjustment1
- 3. Adjustment2
- 4. Adjustment3
- 5. Adjustment7
- 6. Fixed screw hole of valve
- 7. Lock nut 24 A/F
- 8. Hexagon 10 A/F
- 9. O-ring 12X2 apply to the oil orifice A2, B2, P2, T2 (Y)
- 10. Pressure gauge port G1/4" ; 12 deep intend hexagon 6A/F

Required surface finish of mating piece

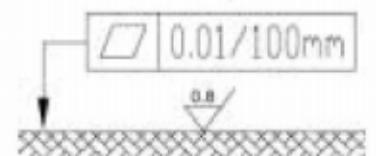

# Instru Center .com

## NOTICE

1. The fluid must be filtered. Minimum filter fineness is 20  $\mu\text{m}$ .
2. The tank must be sealing up and an air filter must be installed on air entrance.
3. Products without subplate when leaving factory, if need them, please ording specially.
4. Vavle fixing screws must be high intensity level (class 10.9). Please select and use them according to the parameter listed in the sample book.
5. Roughness of surface linked with the valve is required to  $0.8 \sqrt{\text{R}}$ .
6. Surface finish of mating piece is required to 0.01/100mm.