

**RE 22 075/02.03**

Replaces: 11.02

**3/2- and 4/2-way directional poppet  
valves, solenoid operated  
Type M-.SEW 10**

Nominal size 10

Series 1X

Maximum operating pressure 420/630 bar

Maximum flow 40 L/min

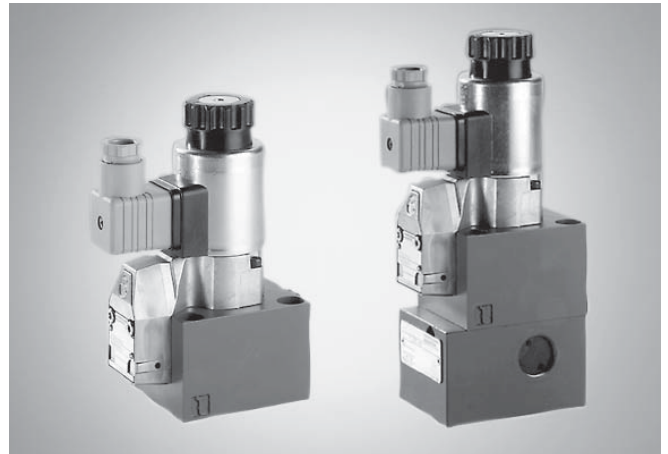

Type M-3SEW 10<sub>D</sub><sup>U</sup>1X/...K4/... with plug-in connector  
(separate order)

**Overview of contents**

Contents	Page
Features	1
Ordering details, preferred types	2
Function, section, symbols	3, 4
Technical data	5
Characteristic curves	6
Performance limits	6
Unit dimensions	7 to 9
Accessories	10
Plug-in connector	11
General guidelines	11
Application examples	12

**Features**

- Direct operated directional poppet valve, solenoid operated
- Porting pattern to DIN 24 340 Form A, ISO 4401 and CETOP–RP 121 H, subplates to catalogue sheet RE 45 054 (separate order)
- Closed port is leak-free
- Switching is ensured even after long periods of being under pressure
- Air gap DC solenoids with removable coil (AC voltage possible via a rectifier)
- Solenoid coil can be rotated by 90°
- Individual electrical connection
- With protected hand override, optional
- Inductive limit switch (contact and contactless), optional, see page 10



© 2003  
by Bosch Rexroth AG, Industrial Hydraulics, D-97813 Lohr am Main

All rights reserved. No part of this document may be reproduced or stored, processed, duplicated or circulated using electronic systems, in any form or by means, without the prior written authorisation of Bosch Rexroth AG. In the event of contravention of the above provisions, the contravening party is obliged to pay compensation.

## Ordering details

M-		SEW	10	1X/	M	K4	/	*
3 actuator ports = 3	4 actuator ports = 4	Further details in clear text						
Poppet valve	No code = NBR seals							
Nominal size 10 = 10	V = FKM seals (other seals on request)							
Actuator ports	3	4						
<b>Symbols</b>								
Series 10 to 19 (10 to 19: unchanged installation and connection dimensions)	= 1X							
Operating pressure up to 420 bar (fixing screws M6)	= 420							
Operating pressure up to 630 bar (fixing screws M8)	= 630							
Solenoid (air gap) with removable coil	= M							
AC supply (permissible voltage tolerance ± 10%)		Nominal voltage of the DC solenoid when used with an AC voltage				Ordering details		
110 V - 50/60 Hz		96 V				G96		
120 V - 60 Hz		110 V				G110		
230 V - 50/60 Hz		205 V				G205		
No code =		Without cartridge check valve, without throttle insert						
P =		With cartridge check valve						
B12 =		Throttle Ø 1.2 mm						
B15 =		Throttle Ø 1.5 mm						
B18 =		Throttle Ø 1.8 mm						
B20 =		Throttle Ø 2.0 mm						
B22 =		Throttle Ø 2.2 mm						
No code =		Without limit switch						
QMAG24 =		Switched position „a“ is monitored						
QMBG24 =		Switched position „b“ is monitored						
K4 <sup>1;2)</sup> =		Without plug-in connector, single connection with component plug DIN EN 175 301-803						
N9 =		With protected hand override						
No code =		Without hand override						
G24 =		24 V DC						
G205 <sup>2)</sup> =		205 V DC						

<sup>1)</sup> Plug-in connectors must be ordered separately (see page 11).

<sup>2)</sup> For the connection to an AC supply a DC solenoid **must** be used which is controlled via a rectifier (see table on the left).

For individual connections a large plug-in connector with integrated rectifier can be used (separate order, see page 11).

### Preferred types (readily available)

Material No.	Type
R900075565	M-3SEW 10 U1X/420MG24N9K4
R900075563	M-3SEW 10 C1X/420MG24N9K4

Further preferred types and standard units are to be found in the EPS (Standard Price List).

## Function, section, symbols: 3/2-way poppet valve

### General:

The type M-.SEW directional valve is a solenoid operated directional poppet valve. It controls the start, stop and directional of a flow. It basically consists of a housing (1), the solenoids (2), the hardened valve system (3) and the spool (8) as the closing element.

### Basic principle:

In the initial position the spool (8) is pressed onto the seat by the spring (9), and in the switched position by the solenoid (2). The solenoid (2) force acts via the lever (6) and the ball (7) on the spool (8), which is sealed on two sides. The chamber between the two sealing elements is connected with port P. The valve system (3) is thereby pressure-balanced with regard to the operating forces (solenoid or return spring). The valves can therefore be used up to a pressure of 630 bar.

### Note:

- The 3/2-way poppet valves have "negative switching overlap". Therefore port T must always be connected. This means that during the switching process – from the start of opening one valve seat to the closing of the other seat – all of the ports P–A–T are connected with each other. This, however takes place in such a short space of time that in most applications it is irrelevant.
- The hand override (10) makes it possible to switch the valve without energising the solenoids.
- Care has to be taken to ensure that the stated maximum flows are not exceeded! If necessary a cartridge throttle for flow limitation has to be fitted (see below).

The following possibilities are obtainable via the seat orientation:

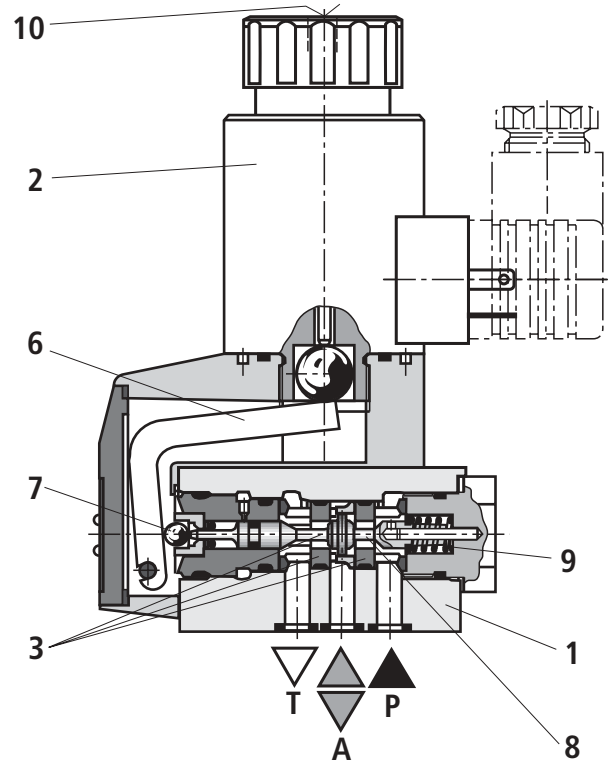
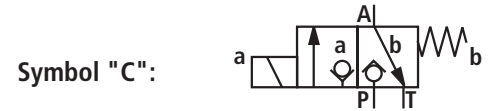
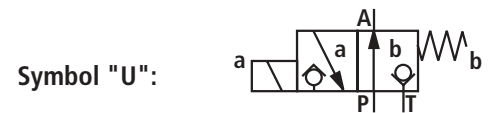

Type M-3SEW 10 U...

### Throttle insert

The use of the throttle insert is necessary when, due to operational conditions during the switching process, flows can occur that exceed the valve performance limits.

Examples:

- Accumulator operation,
- Use a pilot valve with internal pilot oil supply.

#### 3/2-way poppet valve

The throttle insert is fitted into port P of the poppet valve.

#### 4/2-way poppet valve (see page 4)

The throttle insert is fitted into port P of the plus-1-plate.

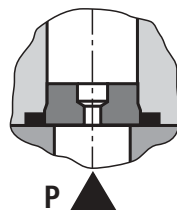

### Cartridge check valve

The cartridge check valve allows free-flow from P to A and provides leak-free closure from A to P.

For examples see page 12.

#### 3/2-way poppet valve

The cartridge check valve is inserted into port P of the poppet valve.

#### 4/2-way poppet valve (see page 4)

The cartridge check valve is inserted into port P of the plus-1 plate.

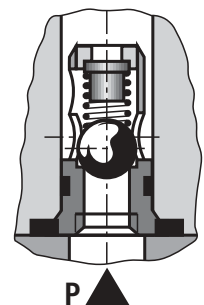

## Function, section, symbols: 4/2-way poppet valve

In conjunction with a sandwich plate, a **plus-1 plate**, under the 3/2-way poppet valve this valve can be used as 4/2-way poppet valve.

Function of the plus-1 plate:

### Initial position:

The main valve is not operated. The spring (9) holds the ball (4) on the seat (11). Port P is closed and A is connected to T. In addition, a control line runs from A to the large area of the control spool (12), which is thus unloaded to tank. The pressure applied via P now moves the ball (13) onto the seat (14). Thus, P is connected to B and A with T.

### Transition position:

When the main valve is operated, the spool (8) is pushed against the spring (9) and then pressed onto the seat (15). Port T is then blocked, P, A and B are connected to each other for a short time.

### Switched position:

P is connected to A. As the pump pressure acts via A on the large area of the control spool (12), the ball (13) is pushed onto seat (16). Thus, B is connected to T and P to A. Ball (13) in the plus-1 plate has a "positive switching overlap".

**In order to avoid pressure intensification when single rod cylinders are used, the annulus area of the cylinder must be connected to A.**

Due to the use of the plus-1 plate and the arrangement of the seats, the following combinations are possible:

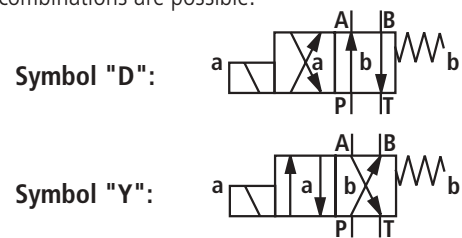

Schematic illustration: Initial position

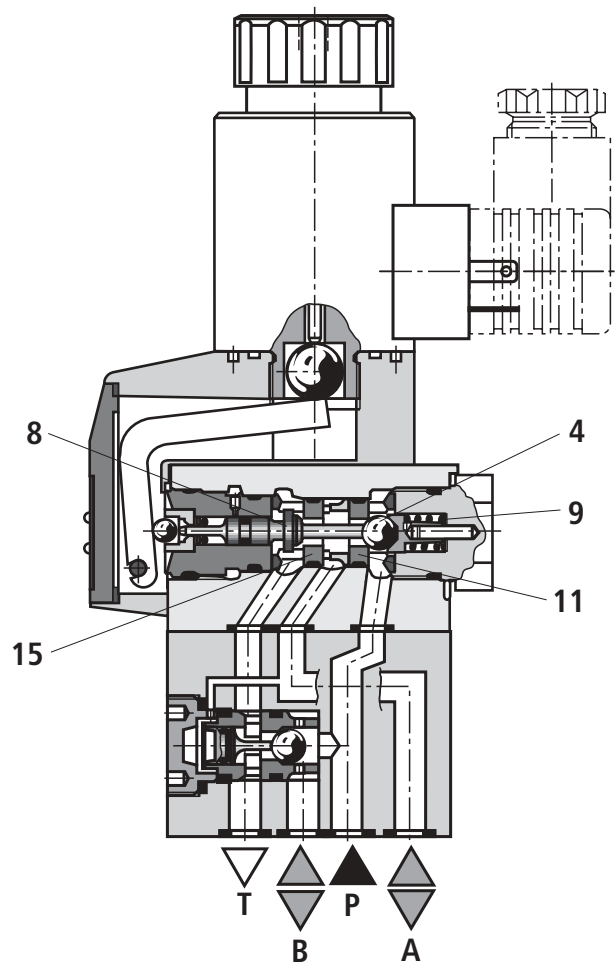
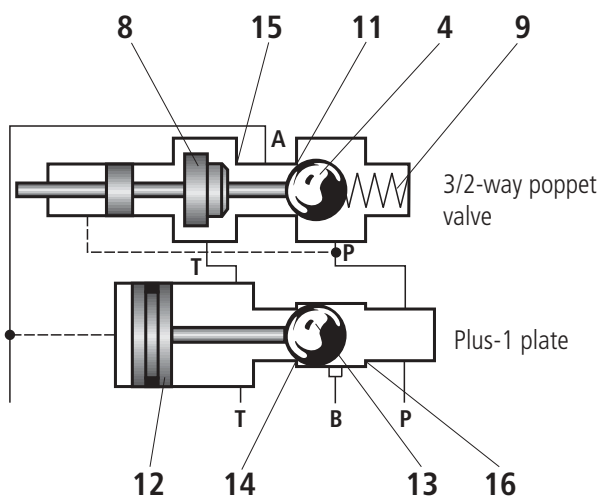

Type M-4SEW 10 Y...

**Technical data** (for applications outside these parameters, please consult us!)

**General**

Installation	Optional		
Ambient temperature range	°C	– 30 to + 50 (NBR seals)	
		– 20 to + 50 (FKM seals)	
Weight	3/2-way poppet valve	kg	2.0
	4/2-way poppet valve	kg	3.5

**Hydraulic**

Maximum operating pressure	bar	See table on page 6
Maximum flow	L/min	40
Pressure fluid		Mineral oil (HL, HLP) to DIN 51 524 <sup>1)</sup> ; Fast bio-degradable pressure fluids to VDMA 24 568 (also see RE 90 221); HETG (rape seed oil) <sup>1)</sup> ; HEPG (polyglycols) <sup>2)</sup> ; HEES (synthetic ester) <sup>2)</sup> ; Other pressure fluids on request
Pressure fluid temperature range	°C	– 30 to + 80 (NBR seals)
		– 20 to + 80 (FKM seals)
Viscosity range	mm <sup>2</sup> /s	2.8 to 500
Cleanliness class to ISO code		Maximum permissible degree of contamination of the pressure fluid is to ISO 4406 (C) class 20/18/15 <sup>5)</sup>

**Electrical**

Voltage type		DC	AC
Available voltages <sup>3)</sup>	V	12, <b>24</b> , 42, 96, 110, 205, 220	Only possible via a rectifier (see ordering details on page 11)
Voltage tolerance (nominal voltage)	%	± 10	
Power consumption	W	30	
Duty	%	100	
Switching time to ISO 6403		See table below	
Switching frequency	cycles/h	15000	
Protection to DIN 40 050		IP 65 with mounted and fixed plug-in connector	
Maximum coil temperature <sup>4)</sup>	°C	150	

<sup>1)</sup> Suitable for NBR **and** FKM seals

<sup>2)</sup> **Only** suitable for FKM seals

<sup>3)</sup> Special voltages on request

<sup>4)</sup> Due to the surface temperatures which occur on the solenoid coils, the European standards EN563 and EN982 must be taken into account!

<sup>5)</sup> The cleanliness class stated for the components must be adhered too in hydraulic systems. Effective filtration prevents faults from occurring and at the same time increases the component service life.

For the selection of filters see catalogue sheets RE 50 070, RE 50 076 and RE 50 081.

**When connecting the electrics, the protective conductor (PE ≡) must be connected according to the relevant regulations.**

**Switching time  $t$  in ms** (installation: solenoid vertical)

Pressure $P$ in bar	Flow $q_v$ in L/min	DC solenoid						DC solenoid + rectifier									
		Symbols U, C, D, Y								Symbols U, C, D, Y							
		Without tank pressure				$t_{on}$		$t_{off}$		Without tank pressure				$t_{on}$		$t_{off}$	
U	C	D	Y	U	C	D	Y	U	C	D	Y	U	C	D	Y		
<b>140</b>	40	20	40	20	40	12	17	20	40	20	40	60	45	40	50		
<b>280</b>	40	25	45	20	45	12	17	20	45	25	45	60	45	45	55		
<b>320</b>	40	25	45	20	45	12	17	25	45	25	45	60	45	45	55		
<b>420</b>	40	30	45	20	50	12	17	25	45	25	50	60	45	45	55		
<b>500</b>	40	30	45	20	50	12	17	30	50	30	50	65	50	60	60		
<b>600</b>	40	30	50	20	50	12	17	30	50	30	50	65	50	60	60		

**Characteristic curves** (measured with HLP 46,  $\vartheta_{oil} = 40\text{ °C} \pm 5\text{ °C}$ )

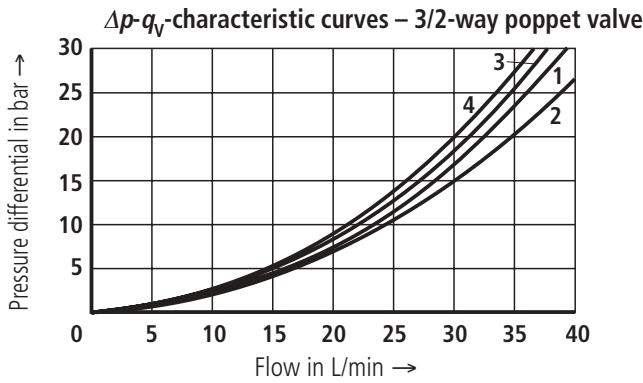

- 1 M-3SEW 10 C..., P to A      3 M-3SEW 10 U..., P to A  
 2 M-3SEW 10 C..., A to T      4 M-3SEW 10 U..., A to T

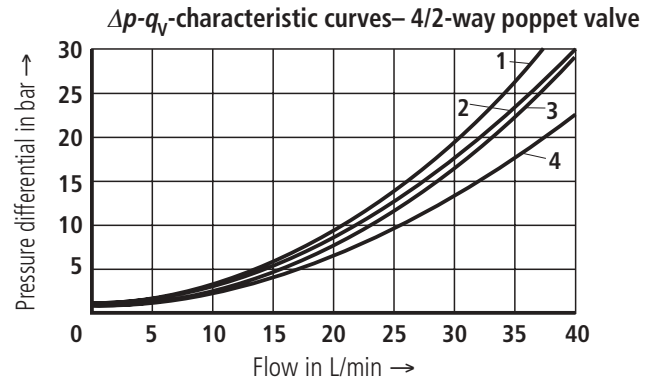

- 1 M-4SEW 10 D<sub>Y</sub>..., A to T      3 M-4SEW 10 D<sub>Y</sub>..., P to B  
 2 M-4SEW 10 D<sub>Y</sub>..., P to A      4 M-4SEW 10 D<sub>Y</sub>..., B to T

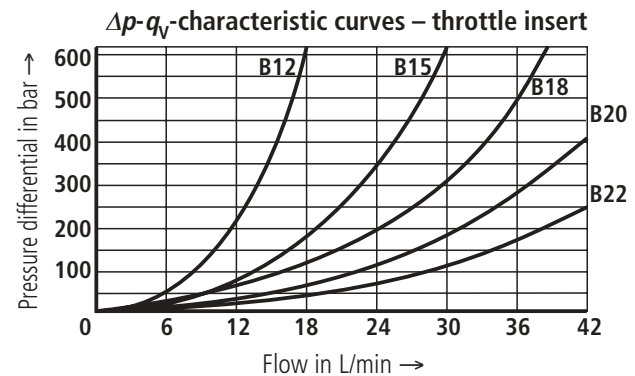
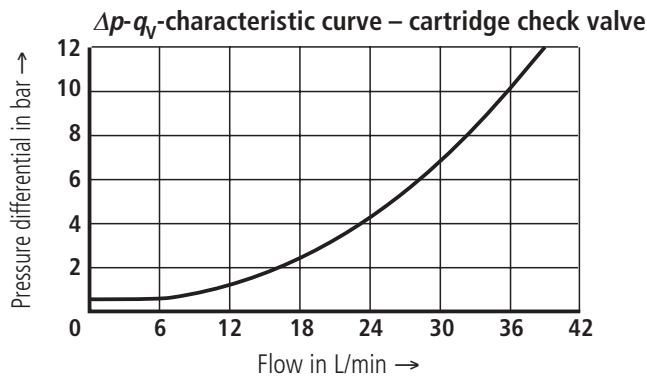

**Performance limits** (measured with HLP 46,  $\vartheta_{oil} = 40\text{ °C} \pm 5\text{ °C}$ )

	Symbol	Description	Operating pressure in bar				Flow in L/min
			P	A	B	T	
<b>3-way circuit</b>		Pressure at P ≥ A ≥ T	420/630	420/630		100	40
			420/630	420/630		100	40
<b>2-way circuit</b> (only for unloading function)		Before switching from the initial position to the switched position, pressure must be present in port A. Pressure at A ≥ T		420/630		100	40
		Pressure at A ≥ T		420/630		100	40
<b>4-way circuit</b> (flow is only possible in the direction of the arrow!)		Single ball valve (symbol „U“) in conjunction with a plus-1 plate P > A ≥ B > T	420/630	420/630	420/630	100	40
		Two ball valve (symbol „C“) in conjunction with a plus-1 plate P > A ≥ B > T	420/630	420/630	420/630	100	40

**⚠ Attention!** Please take into account the „general guidelines“ stated on page 11!

The performance limit was determined with the solenoids at operating temperature, 10% under voltage and with the tank not pressurised.

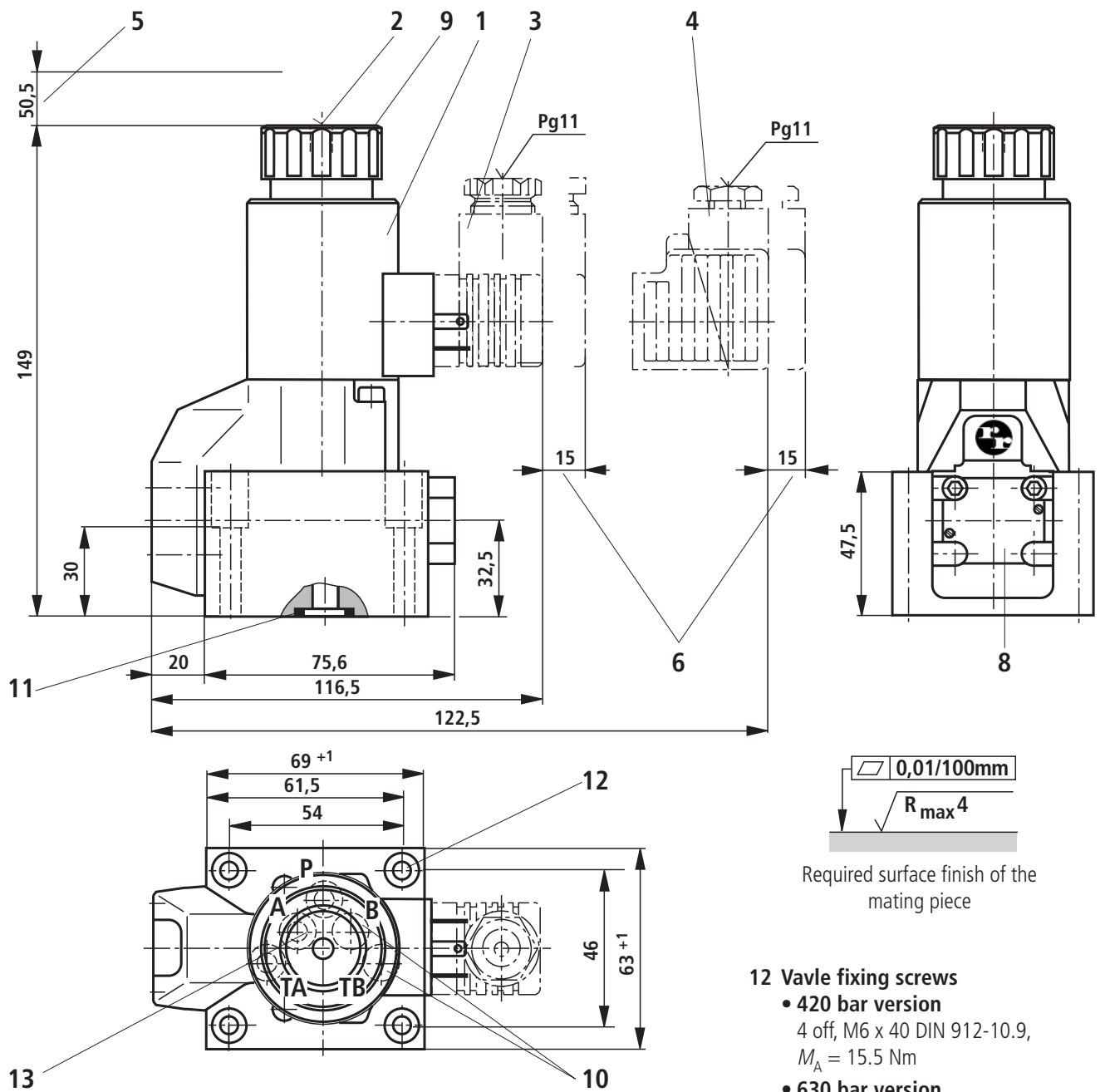

- 1 Solenoid "a" (plug-in connection colour grey)
- 2 Protected hand override "N9"
- 3 Plug-in connector **without** circuitry to DIN EN 175 301-803 <sup>1)</sup>
- 4 Plug-in connector **with** circuitry to DIN EN 175 301-803 <sup>1)</sup>
- 5 Space required to remove the coil
- 6 Space required to remove the plug-in connector
- 8 Name plate

- 9 Fixing nut, tightening torque  $M_A = 4$  Nm
- 10 **⚠ Attention!**  
On 3/2-way poppet valves, ports B and TB for the 420 bar version are blind counterbores and are not present the 630 bar version.
- 11 Identical seal rings for ports A, B, TA and TB  
Seal ring for port P

**12 Valve fixing screws**

- **420 bar version**  
4 off, M6 x 40 DIN 912-10.9,  
 $M_A = 15.5$  Nm
- **630 bar version**  
4 off, M8 x 60 DIN 912-10.9,  
 $M_A = 37$  Nm  
must be ordered separately.

**13** Porting pattern to DIN 24 340 Form A, ISO 4401 and CETOP-RP 121 H

**Subplates**

- **420 bar version**  
G 66/01 (G3/8)  
G 67/01 (G1/2)
- **630 bar version**  
G 308/01 (G3/8)  
G 292/01 (G31/2)  
to catalogue sheet RE 45 054  
must be ordered separately.

<sup>1)</sup> Must be ordered separately, see page 11.

**Unit dimensions:** 4/2-way poppet valve, 420 bar version (dimensions in mm)

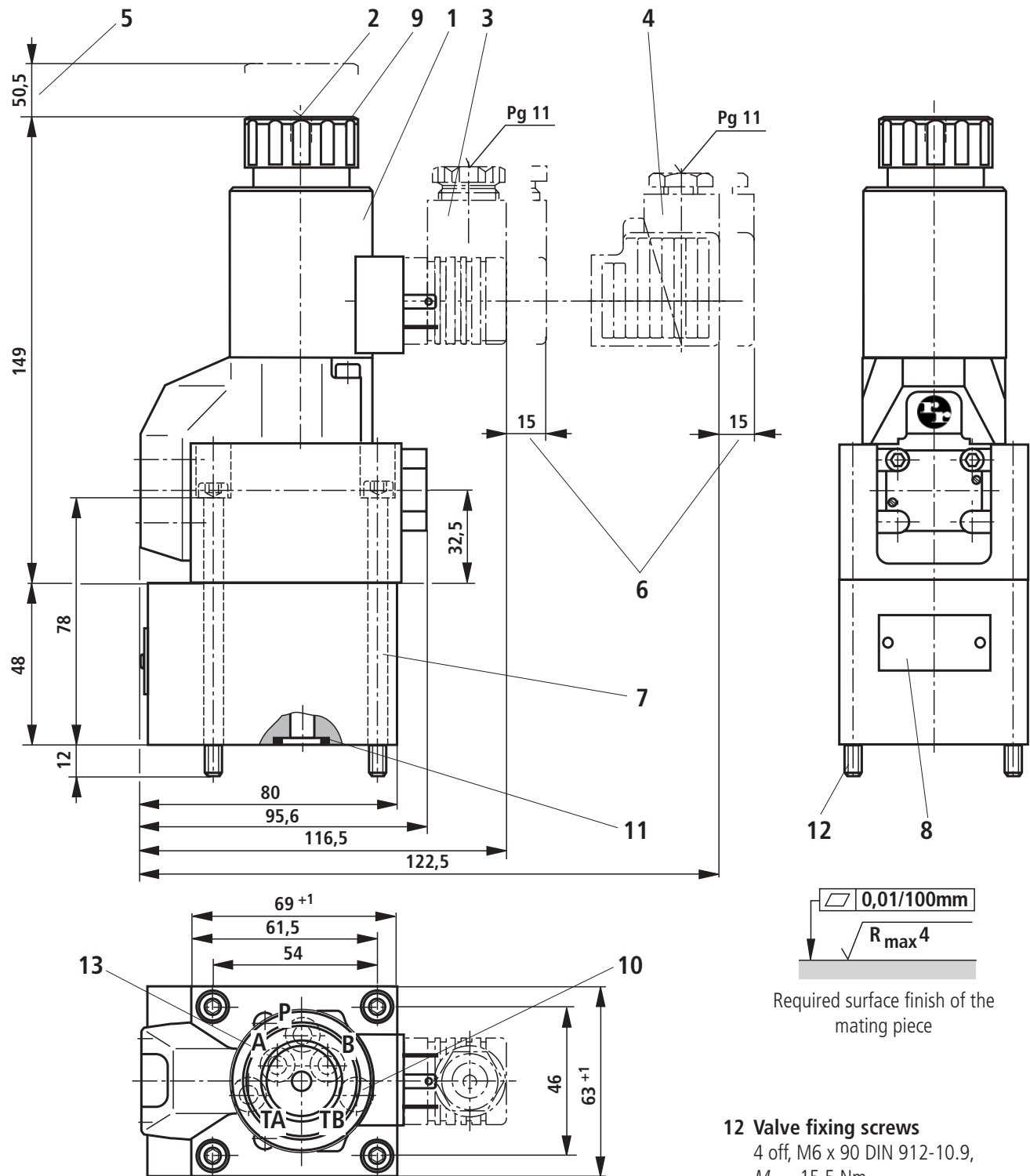

- 1 Solenoid "a" (plug-in connector colour grey)
- 2 Protected hand override "N9"
- 3 Plug-in connector **without** circuitry to DIN EN 175 301-803 <sup>1)</sup>
- 4 Plug-in connector **with** circuitry to DIN EN 175 301-803 <sup>1)</sup>
- 5 Space required to remove the coil
- 6 Space required to remove the plug-in connector

- 7 Plus-1 plate
- 8 Name plate
- 9 Fixing nut, tightening torque  $M_A = 4 \text{ Nm}$
- 10 **⚠ Attention!**  
On the 4/2-way poppet valves, port TB is a blind counterbore.
- 11 Identical seal rings for ports A, B, TA and TB  
Seal ring for port P

**12 Valve fixing screws**

4 off, M6 x 90 DIN 912-10.9,  $M_A = 15.5 \text{ Nm}$  are included within the scope of supply.

**13 Porting pattern to DIN 24 340 Form A, ISO 4401 and CETOP-RP 121 H**

**Subplates**

G 66/01 (G3/8)  
G 67/01 (G1/2)  
to catalogue sheet RE 45 054 must be ordered separately.

<sup>1)</sup> Must be ordered separately, see page 11.



**Unit dimensions:** 4/2-way poppet valve, 630 bar version (dimensions in mm)

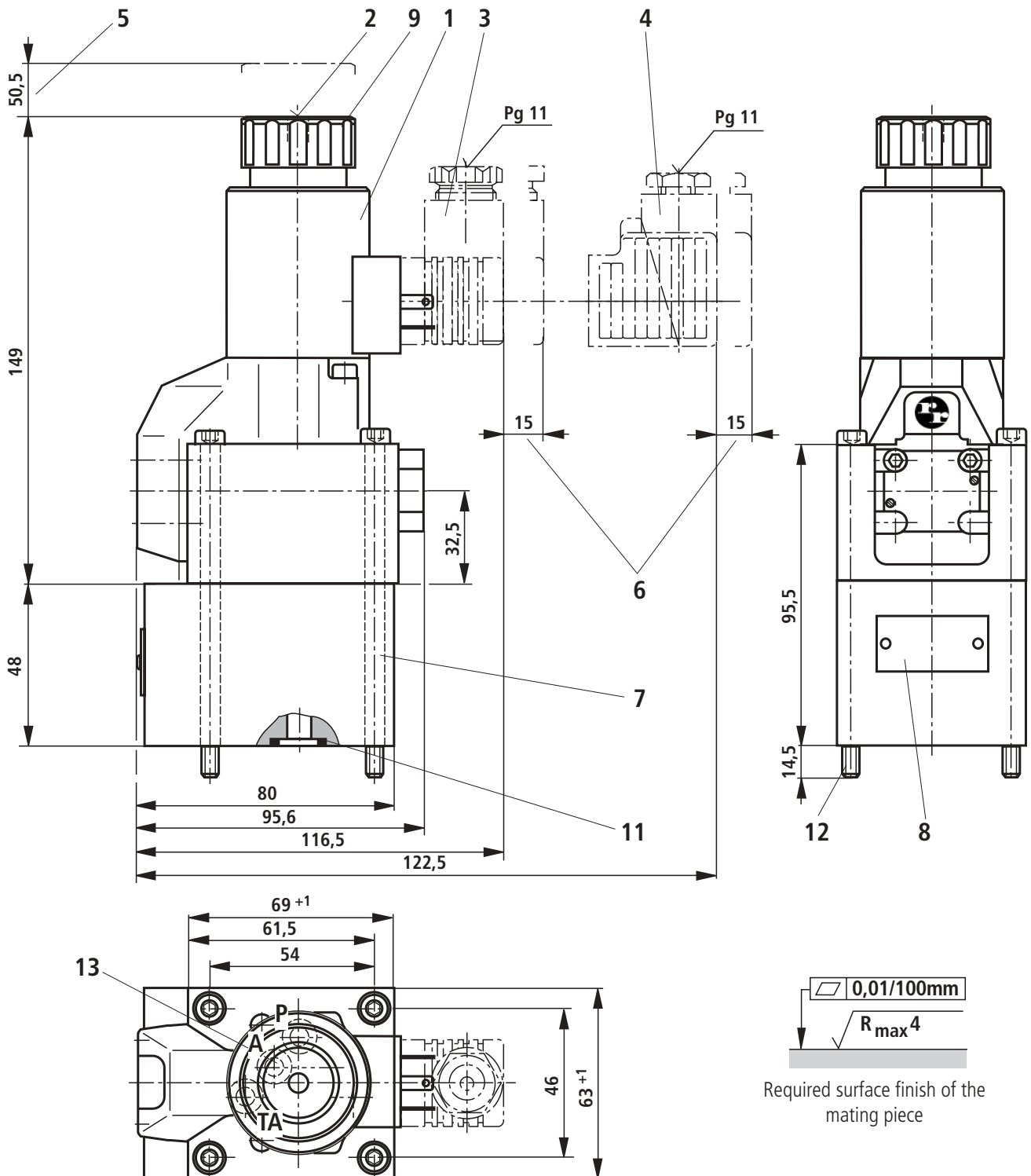

- 1 Solenoid "a" (plug-in connector colour grey)
- 2 Protected hand override "N9"
- 3 Plug-in connector **without** circuitry to DIN EN 175 301-803 <sup>1)</sup>
- 4 Plug-in connector **with** circuitry DIN EN 175 301-803 <sup>1)</sup>
- 5 Space required to remove the coil
- 6 Space required to remove the plug-in connector

- 7 Plus-1 plate
- 8 Name plate
- 9 Fixing nut, tightening torque  $M_A = 4 \text{ Nm}$
- 11 Identical seal rings for ports A and TA  
Seal ring for port P
- 12 **Valve fixing screws**  
4 off, M8 x 110 DIN 912-10.9,  $M_A = 37 \text{ Nm}$  are included within the scope of supply.

- 13 Porting pattern to DIN 24 340 Form A, ISO 4401 and CETOP-RP 121 H

**Subplates**

G 377/01 (G3/8)  
G 378/01 (G1/2)  
to catalogue sheet RE 45 054 must be ordered separately.

<sup>1)</sup> Must be ordered separately, see page 11.

**Accessories:** inductive limit switch (dimensions mm)

Monitored switched position	Ordering details	Limit switch
Switched position „a“ is monitored	QMAG24	Damped
Switched position „b“ is monitored	QMBG24	Undamped

The electrical connection is via a 4-pin plug-in connector with an M12 x 1 connection thread.

**The plug-in connector has to be ordered separately (see RE 08 006).**

For further details regarding the

- Operating voltage,
- Current consumption,
- Load capacity of the outputs,
- Contact allocation,

see RE 24 830.

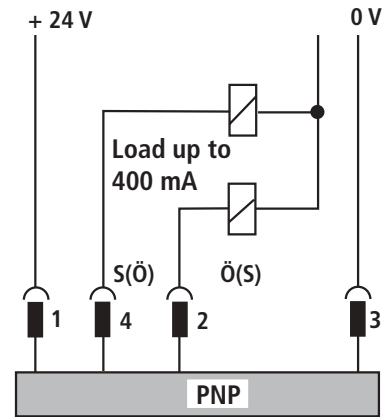

The inductive limit switch can be connected as a normally open or normally closed switch (see RE 24 830).

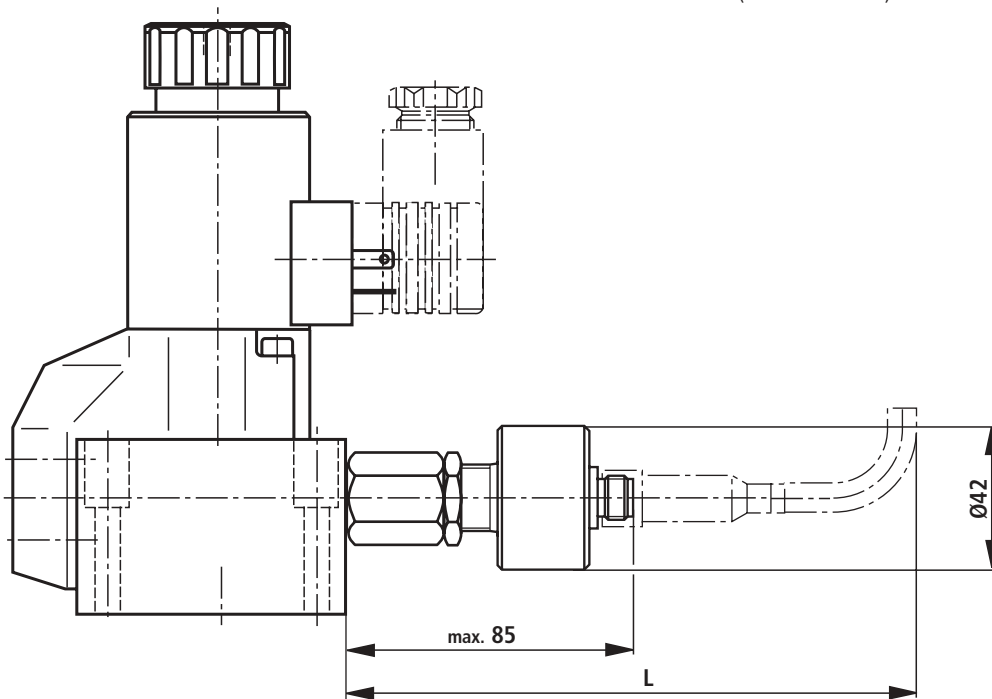

**⚠ Attention!**

It has to be ensured that terminal 1 of the plug-in connector is connected!

**Dim. L** (plug-in connector, 10 mm withdrawal room and minimum bend radius for the connection cable). For plug-in connectors see RE 08 006.

Straight plug-in connector <b>Material No. R900031155</b>	183
Angled plug-in connector <b>Material No. R900082899</b>	114
Plug-in connector with moulded on cable <b>Material No. R900064381</b>	153

**Plug-in connectors** to DIN EN 175 301-803 and ISO 4400 for component plug "K4"

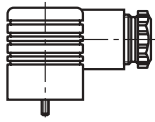
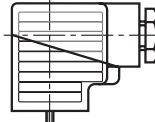
For further plug-in connectors see RE 08 006					
		<b>Material No.</b>			
Valve side	Colour	Without circuitry	With light indicator 12 ... 240 V	With recifier 12 ... 240 V	With light indicator and Z-diode protective circuit 24 V
a	Grey	<b>R900074683</b>	–	–	–
a/b	Black	–	<b>R900057292</b>	<b>R900313933</b>	<b>R900310995</b>

**General guidelines**

- In order to operate the valve safely and to hold it safely in the switched position, the pressure in P must be  $\geq A \geq T$  (for design reasons).
- The ports P, A and T (3/2-way poppet valve) as well as P, A, B and T (4/2-way poppet valve) are positively assigned to their individual functions. They must not be interchanged or plugged. Flow is only permitted in the direction of the arrow.
- When using the plus-1 plate (4/2-way function) the following lower operating values must be taken into account:  
 $p_{\min} = 8 \text{ bar}$ ;  $q_v > 3 \text{ L/min}$ .
- The specified maximum flow must not be exceeded.

## Application examples

These examples serve **only to explain** the possibilities offered by the poppet valve. They do not include all of the functions.

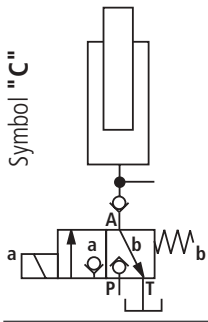
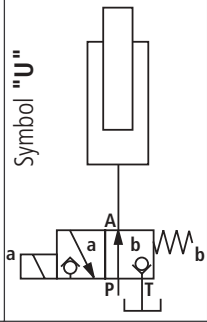
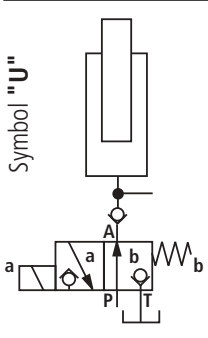
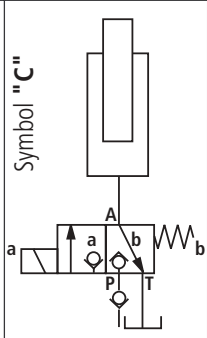
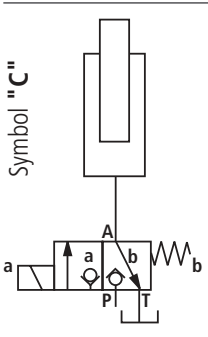
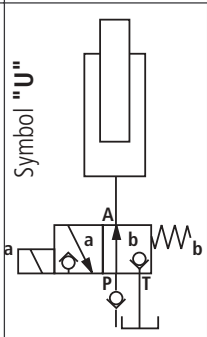
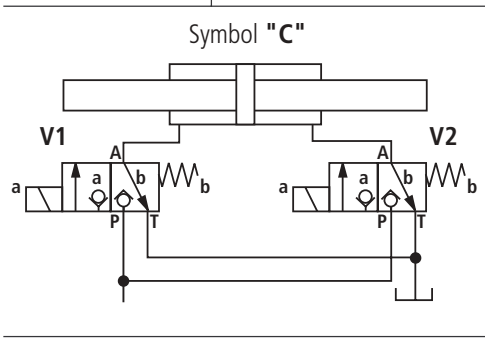
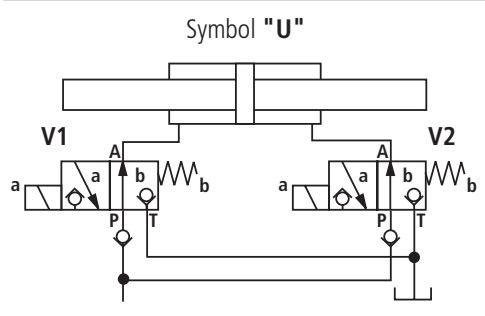
<p>Symbol "C"</p> 	<p><b>2/2-way circuit with a two poppet valve and check valve at port A</b></p> <p>The check valve must be installed in the pipework.</p> <p><b>Initial position:</b> Flow blocked, maximum pressure permissible. Pressure is held in the actuator, even when the pump is switched off, due to the check valve at port A.</p> <p><b>Switched position:</b> Free-flow, maximum pressure permissible. Leakage drained via port T. The only leakage occurring is that which flows to T during the switching process.</p>	<p>Symbol "U"</p> 	<p><b>3/2-way circuit with a single poppet valve</b></p> <p><b>Initial position:</b> Lifting Holding only due to limitation of travel and pressure in port P.</p> <p><b>Switched position:</b> Lowering</p>
<p>Symbol "U"</p> 	<p><b>2/2-way circuit with a single poppet valve and check valve at port A</b></p> <p>The check valve must be fitted in the pipework.</p> <p><b>Initial position:</b> Free-flow, maximum pressure permissible. Pressure is held in the actuator, even when the pump is switched off, due to the check valve at port A.</p> <p><b>Switched position:</b> Flow blocked, maximum pressure permissible. Leakage drained via port T. The only leakage occurring is that which flows to T during the switching process.</p>	<p>Symbol "C"</p> 	<p><b>3/2-way circuit with a two poppet valve and cartridge check valve in port P</b></p> <p>The check valve is fitted in the P port of the 3/2-way poppet valve.</p> <p><b>Initial position:</b> Lowering</p> <p><b>Switched position:</b> Lifting</p> <p>The load can be held in any position while the pump is switched off and the solenoid energised.</p>
<p>Symbol "C"</p> 	<p><b>3/2-way circuit with a two poppet valve</b></p> <p><b>Initial position:</b> Lowering</p> <p><b>Switched position:</b> Lifting</p> <p>Holding only due to limitation of travel and pressure in port P.</p>	<p>Symbol "U"</p> 	<p><b>3/2-way circuit with a single poppet valve and cartridge check valve in port P</b></p> <p>The check valve is fitted into the P port of the 3/2-way poppet valve.</p> <p><b>Initial position:</b> Lifting</p> <p>The load can be held in any position while the pump is switched off.</p> <p><b>Switched position:</b> Lowering</p>
<p>Symbol "C"</p> 		<p><b>4/3- (4/4-) way circuit with a 2 two poppet valves</b></p> <p><b>V1 and V2 in the initial position:</b> Both cylinder sides are connected to the tank port.</p> <p><b>V2 in the switched position:</b> The piston moves to the left</p> <p><b>V1 in the switched position:</b> The piston moves to the right</p> <p><b>V1 and V2 in the switched position:</b> Both cylinder sides are connected to the pump port. Rapid traverse is possible when a single rod cylinder with an area ratio of 2 : 1, is used.</p> <p><b>⚠ Attention!</b> When using single rod cylinders, the performance limit (double flow) and the maximum permissible operating pressure (pressure intensification) of the valve must be taken into account.</p>	
<p>Symbol "U"</p> 		<p><b>4/3- (4/4-) way circuit with 2 two poppet valves and cartridge check valve in port P of the 3/2-way poppet valves</b></p> <p><b>V1 and V2 in the initial position:</b> The piston is locked externally to prevent movement.</p> <p><b>V2 in switched position:</b> The piston moves to the right</p> <p><b>V1 in the switched position:</b> The piston moves to the left</p> <p><b>V1 and V2 in the switched position:</b> Both cylinders sides are connected to the tank port.</p> <p><b>⚠ Attention!</b> When using single rod cylinders, the performance limit (double flow) and the maximum permissible operating pressure (pressure intensification) of the valve must be taken into account!</p>	

### Bosch Rexroth AG Industrial Hydraulics

D-97813 Lohr am Main  
Zum Eisengießer 1 • D-97816 Lohr am Main  
Telefon 0 93 52 / 18-0  
Telefax 0 93 52 / 18-23 58 • Telex 6 89 418-0  
eMail documentation@boschrexroth.de  
Internet www.boschrexroth.de

### Bosch Rexroth Limited

Cromwell Road, St Neots,  
Cambs, PE19 2ES  
Tel: 0 14 80/22 32 56  
Fax: 0 14 80/21 90 52  
eMail: info@boschrexroth.co.uk

The data specified above only serves to describe the product. No statements concerning a certain condition or suitability for a certain application can be derived from our information. The details stated do not release you from the responsibility for carrying out your own assessment and verification. It must be remembered that our products are subject to a natural process of wear and ageing.