

**Rexport**

**Throttle/Isolating and Throttle/Check Valves  
Type DV/DRV**

RE32502/12.2004

Size 6 to 40

up to 35MPa

up to 375 L/min

Replaces:  
RE32502/5.2001

**Features:**

- threaded connection
- Subplate mounting

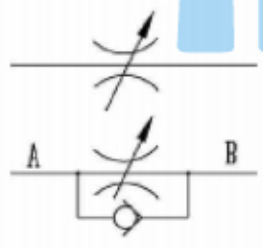

**Instru  
Center**

**Function, Section**

The throttle/isolating valves type DV serve to set an exact oil flow, and can be used for shut-off function, too. The throttle/check valves type DRV serve to set an exact oil flow in one direction, and to allow free return flow in the opposite direction. They consist basically of a housing (1), adjustment knob (2) with locking device (3). By turning the adjustment knob (2) to the left, the spindle (4) with throttle pin (5) increases the flow section (6) to maximum. By turning the adjustment knob (2) to the right, the spindle (4) with throttle pin (5) decreases the flow section (6) until fully closed without leakage. For repeat setting, a colour scale (7) is provided on the top end of the spindle (4). The area of coloured triangle (8) showing indicates how far the valve is open (the larger the coloured triangle the greater the opening). The flow setting is locked by means of locking device (3).

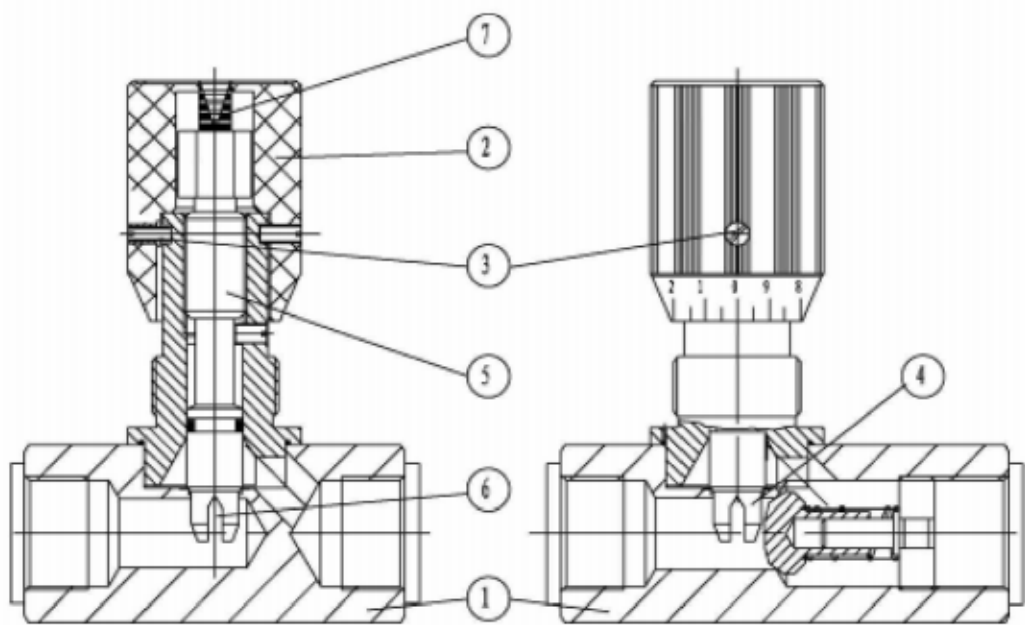

Type DV...10B/...

Type DRV...10B/...

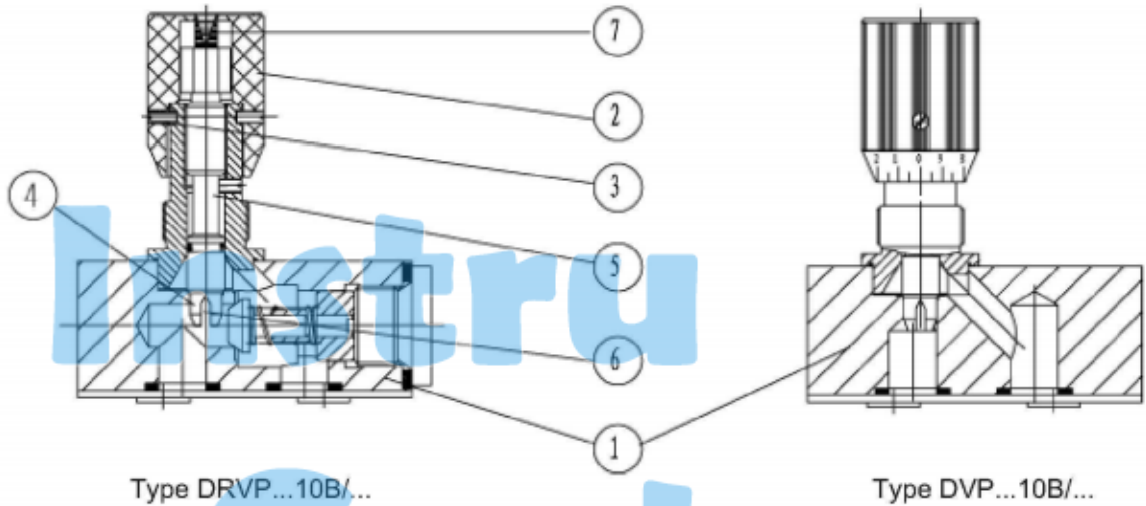

**Ordering Code**

— 10 / \*

- Throttle/isolating valves (threaded connection) = DV
- Throttle/check valves (threaded connection) = DR
- Throttle/isolating valves (subplate mounting) = DVP
- Throttle/check valves (subplate mounting) = DRVP

Size	
6	=6
8	=8
10	=10
12	=12
16	=16
20	=20
25	=25
30	=30
40	=40

- For direct thread connection = -
- For subplate mounting = S

Further details in clear text

- No code = British
- 2 = Metric

- V = Phosphate ester
- No code = Mineral oil

10 = Series 10 to 19 (10 to 19: unchanged installation and connection dimensions)

- 1 = Steel
- 2 = Brass
- 3 = Stainless steel

**Technical Data** ( For applications outside these parameters, please consult us!)

Material	Steel	Brass	Stainless steel
Max. permissible operating pressure (MPa)	to 35	to 15	to 35
Cracking pressure of check valve (type DRV)	0.05 (cracking pressures available if required)		
Fluid	Mineral oil or Phosphate ester		
Fluid temperature range (°C)	-30 to +80		
Viscosity range (mm <sup>2</sup> /s)	10 to 800		
Installation position	optional		

**Operating Curves:** (measured at  $v = 41 \text{ mm}^2 / \text{s}$  and  $t = 50^\circ\text{C}$ )

$\Delta p - q_v$ -operating curves for free return flow via open check valve; direction of flow: A  $\rightarrow$  B

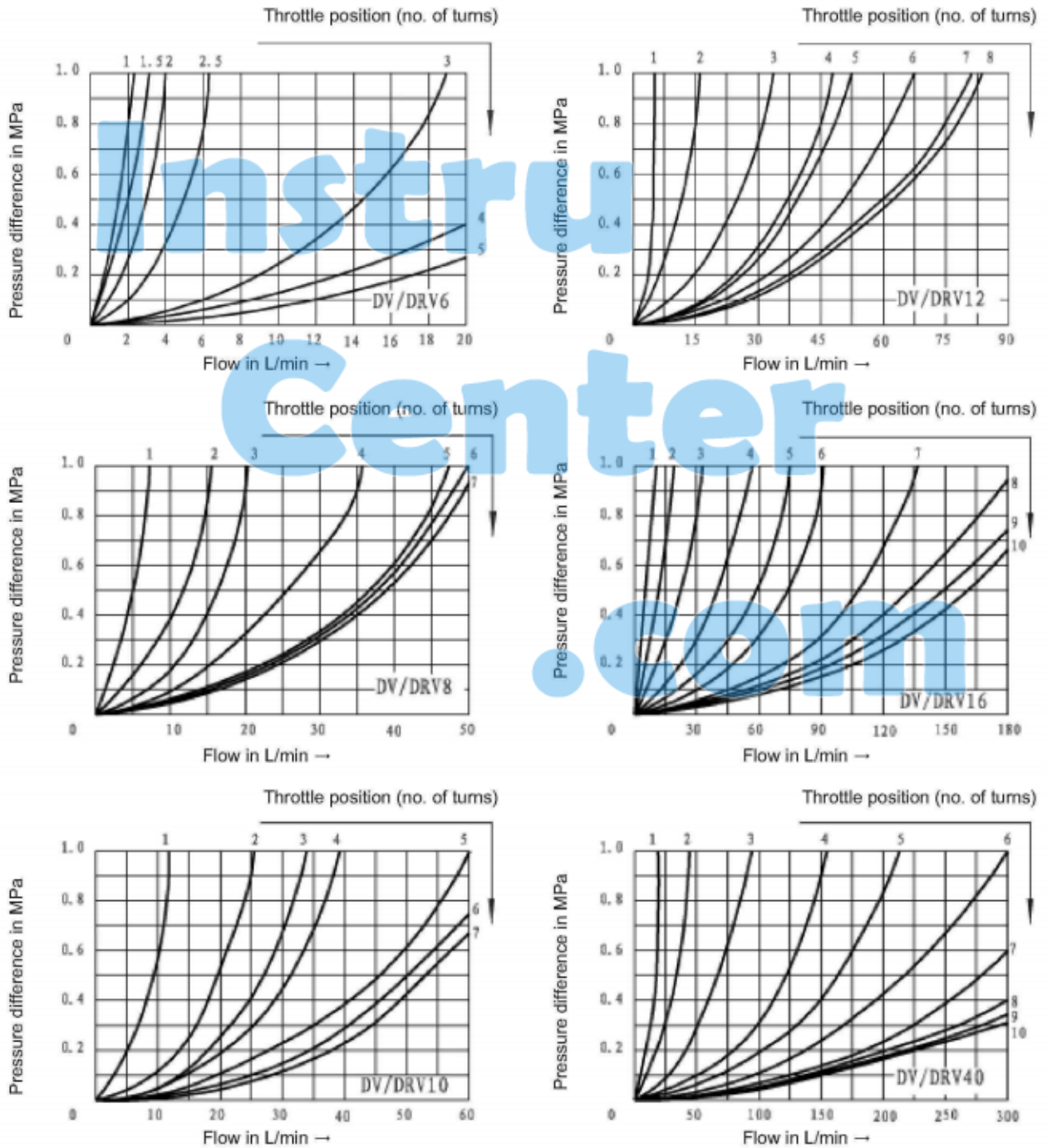

$\Delta p - q_v$ -operating curves for free return flow via open check valve; direction of flow: B  $\rightarrow$  A

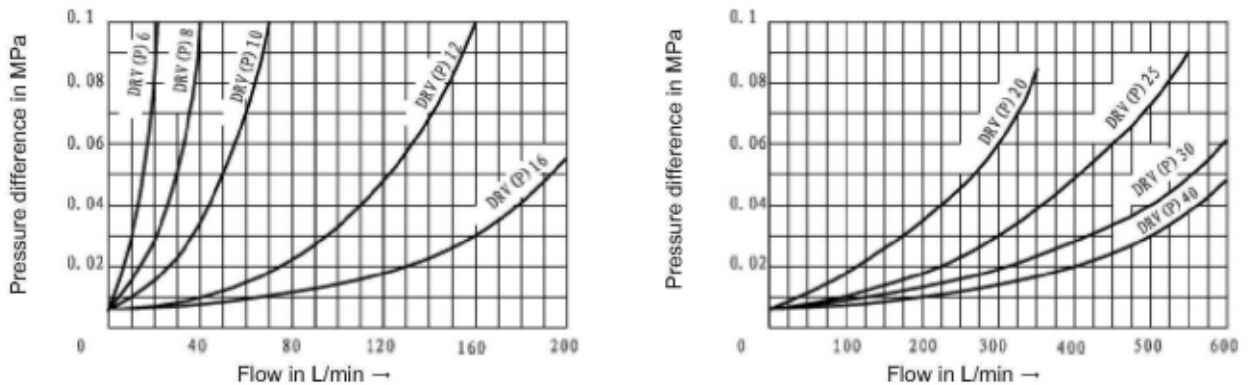

Unit Dimensions: type DV/DRV

(dimensions in mm)

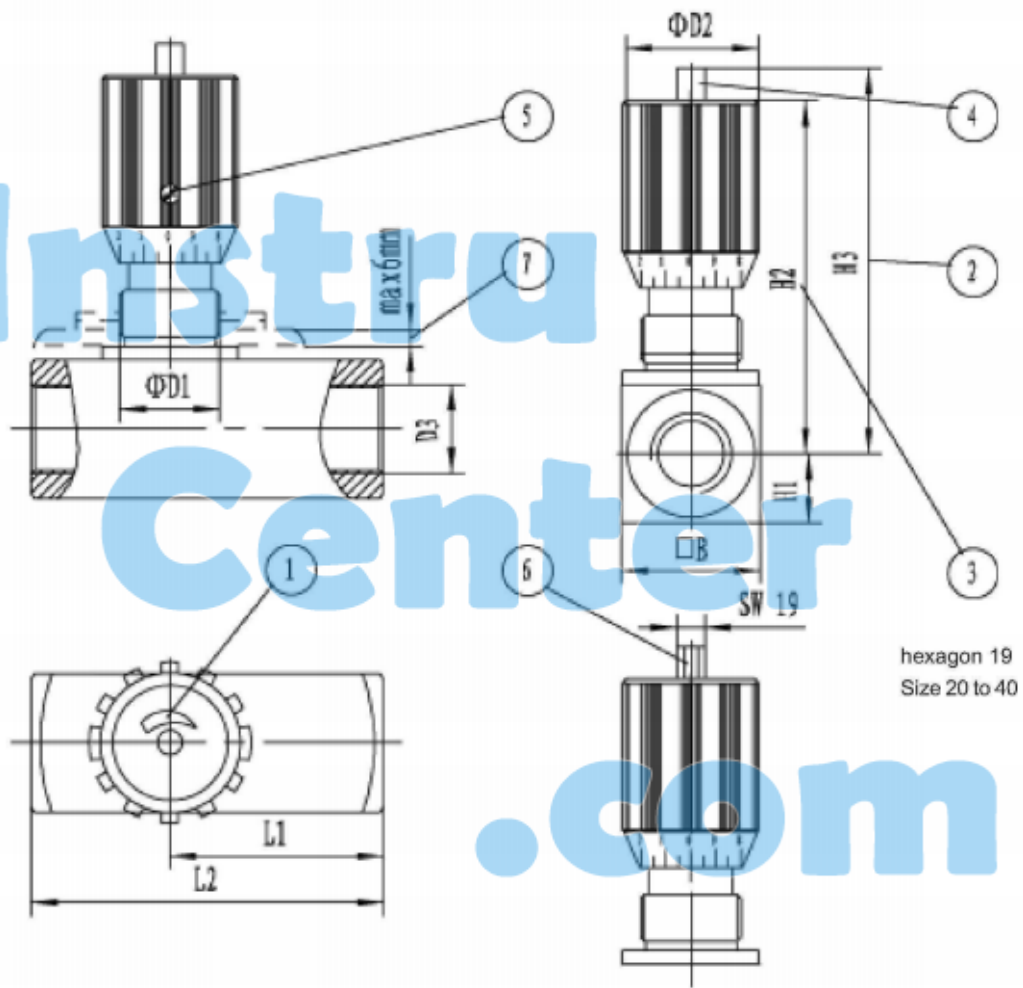

hexagon 19  
Size 20 to 40

Size	□ B	Φ D1	Φ D2	D3		D4	H1	H2	H3	L1		L2	
6	16	16	24	G1/8"	M10X1	M14X1.5	8	54	59	19	26	38	45
8	25	19	29	G1/4"	M14X1.5	M18X1.5	12.5	66	73	24	33.5	48	55
10	30	19	29	G3/8"	M18X1.5	M18X1.5	15	68	75	29	41	58	65
12	35	23	38	G1/2"	M22X1.5	M22X1.5	17.5	82	92	34	44	68	73
16	45	23	38	G3/4"	M27X2	M22X1.5	22.5	97	107	39	57	78	88
20	50	35	49	G1"	M33X2	M33X2	25	128	145	54	77	108	127
25	60	35	49	G1 1/4"	M42X2	M33X2	30	133	150	54	93	108	143
30	70	35	49	G1 1/2"	M48X2	M33X2	35	138	155	54	108	108	143
40	90	35	49	G2"	M60X2	M33X2	45	148	165	54	130	108	165

1 Anti-clockwise rotation increases flow  
Clockwise rotation reduces flow  
2 Throttle fully open  
3 Throttle closed

4 Multi color for repeat setting  
5 Screw to lock flow setting  
6 Hexagon 19 A/F  
7 Panel thickness

**Unit Dimensions: type DVP**

**(dimensions in mm)**

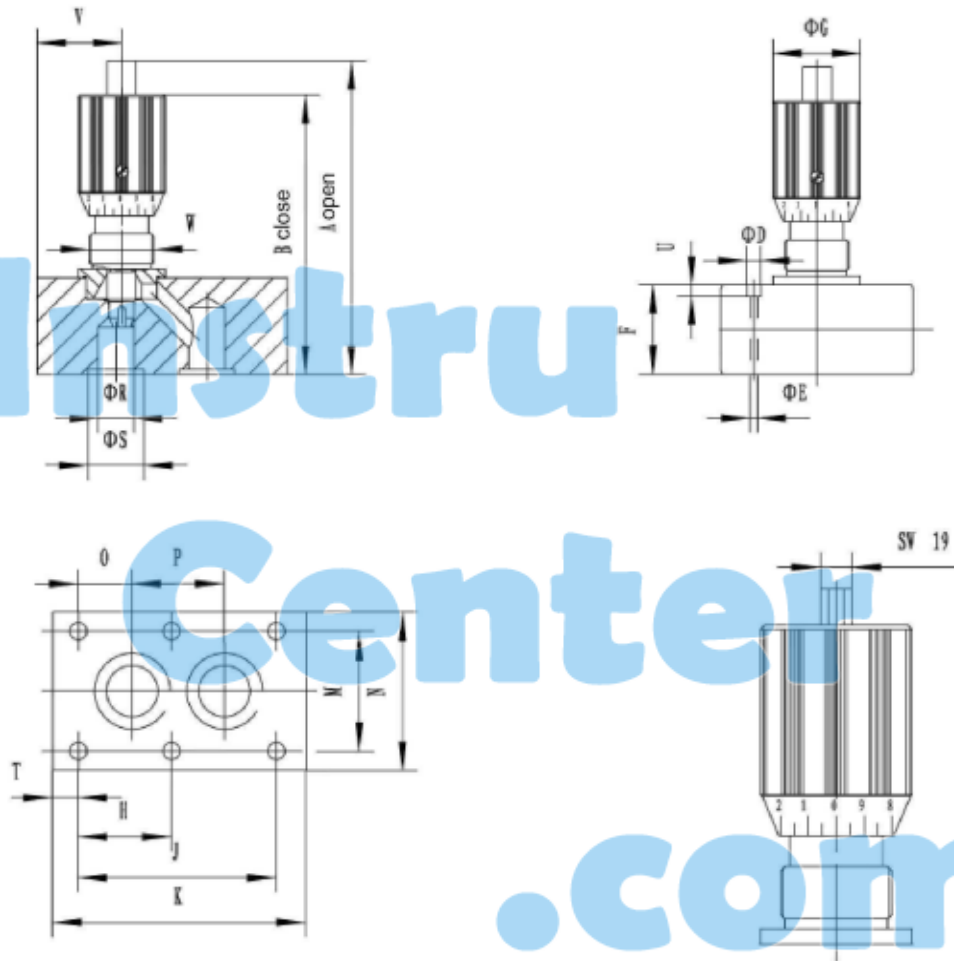

hexagon 19  
Size 20 to 40

Size	A	B	D	E	F	G	H	J	K	M
6	69	64	11	6.6	18	24	-	19	35	28.5
8	80	73	11	6.6	20	24	-	35	47.5	33.5
10	85	78	11	6.6	25	29	-	33.5	51	38
12	99	89	11	6.6	25	29	-	38	75	44.5
16	114	104	14	9	30	38	38	76	93.5	54
20	165	148	14	9	45	38	47.5	95	111	60
25	165	148	18	11.5	45	49	60	120	143	76
30	170	153	20	14	50	49	71.5	143	171	92
40	170	153	20	14	50	49	67	133.5	192	111
Size	N	O	P	R	S	T	U	V	W	Weight(kg)
6	41.5	1.6	16	5	12.2	8	7	11	M14X1.5	0.2
8	46	4.5	25.5	7	13.7	6.5	7	13.5	M18X1.5	0.4
10	51	4	25.5	10	15.7	8.5	7	16	M18X1.5	0.6
12	57.5	4	30	13	21.8	18.5	7	26	M22X1.5	1.00
16	70	11.4	54	16	24.5	8.5	9	23.5	M22X1.5	1.70
20	76.5	19	57	22	31.5	8	9	34	M33X2	3.60
25	100	20.6	79.5	28.5	39.2	11	11	45	M33X2	5.50
30	115	23.8	95	31	41	15	13	39	M33X2	7.50
40	140	25.5	89	45	54	16	13	60	M33X2	8.20

**Unit Dimensions: type DRVP**

**(dimensions in mm)**

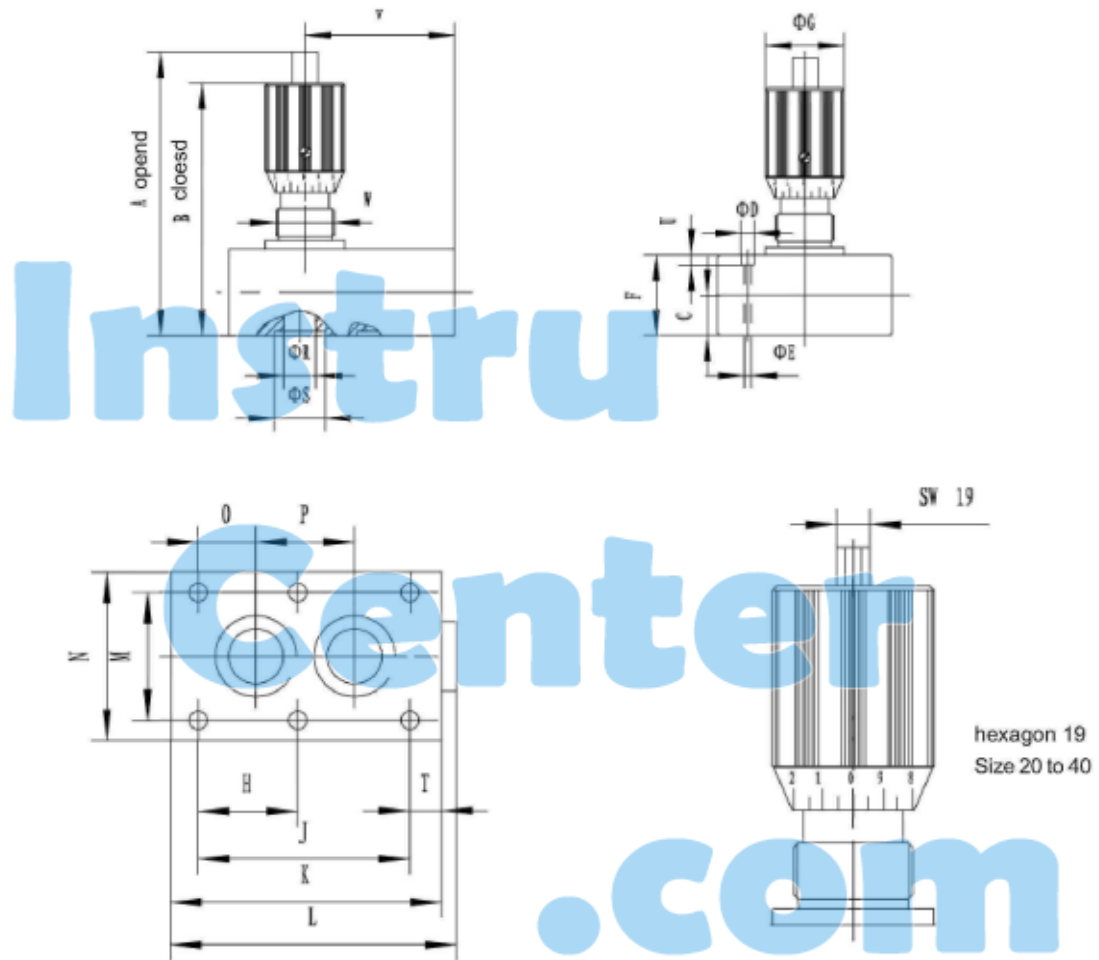

Size	A	B	C	D	E	F	G	H	J	K	L
6	74	69	11.5	11	6.6	23	24	-	19	41.5	45.5
8	84	77	13	11	6.6	24	24	-	35	63.5	67
10	87	80	13.5	11	6.6	27	29	-	33.5	70	74
12	106	96	16	11	6.6	32	29	-	38	80	84
16	129	119	22.5	14	9	45	38	38	76	104	109
20	170	153	26	14	9	50	38	47.5	95	127	132
25	178	161	29	18	11	58	49	60	120	165	170
30	195	178	37.5	20	14	75	49	71.5	143	186	192
40	220	203	50	20	14	100	49	67	133.5	192	198
Size	M	N	O	P	R	S	T	U	V	W	Weight(kg)
6	28.5	41.5	1.6	16	6	12.2	16.1	8	29.5	M14X1.5	0.26
8	33.5	46	4.5	25.5	8	13.7	14.3	10	42.5	M18X1.5	0.50
10	38	51	4	25.5	10	15.7	18.5	7	45	M18X1.5	0.80
12	44.5	57.5	4	30	13	21.8	21	7	45.5	M22X1.5	1.10
16	54	70	11.4	54	17	24.5	16	12	54	M22X1.5	2.50
20	60	76.5	19	57	22	31.5	16	12	70	M33X2	3.90
25	76	100	20.6	79.5	28.5	39.2	30	13	83	M33X2	6.70
30	92	115	23.8	95	31	41	28	13	87.5	M33X2	11.00
40	111	140	25.5	89	45	54	42.5	18	116	M33X2	17.50

# Instru Center .com

## NOTICE

1. The fluid must be filtered. Minimum filter fineness is 20  $\mu\text{m}$ .
2. The tank must be sealing up and an air filter must be installed on air entrance.
3. Products without subplate when leaving factory, if need them, please ording specially.
4. Vavle fixing screws must be high intensity level (class 10.9). Please select and use them according to the parameter listed in the sample book.
5. Roughness of surface linked with the valve is required to  $0.8 \sqrt{\text{R}}$ .
6. Surface finish of mating piece is required to 0.01/100mm.