

# Rexport

## HY Piston Pump

Swash plate design axial Fixed & Variable piston pump

Apply to open circuits

Size:2.5-320

Normal pressure :315 bar

Peak pressure : 400bar

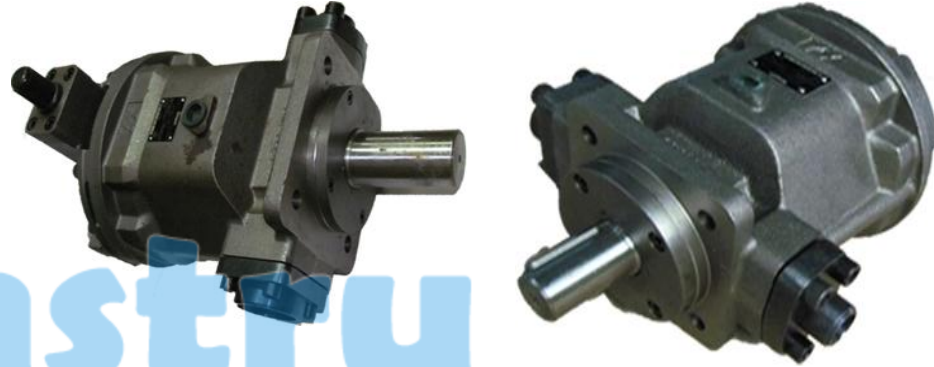

**HY 125 Y -- R P**

**Pump Type :**

- ◆ High pressure sloping cam plate axial piston pump
- ◆ Rated Pressure is 315 bar
- ◆ Max Pressure is 400 bar
- ◆ SAE flange jointing with oil inlet & outlet
- ◆ Open Loop

**Displacement:** 2.5,10,16,18,25,28,32,40,  
(ml/r) 45,55,63,71,80,90,  
100,125,140,160,200,  
225,250,280,300

**Shaft Extension:** P—Key(GB1096-79)

Z—Splined(DIN5480)

S—Splined shaft(GB3478.1-83)

**Turning(See from shaft end):** R—clockwise

L-- anticlockwise

M—Fixed Displacement

**Control Means:** Y—constant power variable

P—constant pressure variable

B—Electrohydraulic proportion

S—Manual variable

YP— constant power and pressure

DP—Electromagnetism unload constant pressure

DY—Electromagnetism unload constant power

DYP—Electromagnetism unload constant power and pressure

Displacement		V g	ml/r	10	16	28	45	71	100	125	140	160	200	250	300
Max speed		n max	rpm	3000	3000	3000	3000	2600	2600	2600	1800	1800	1800	1800	1800
Max. flow	in 1000 r/min	q v	L/min	10	16	28	45	71	100	125	140	160	200	250	300
	in 1500 r/min			15	24	42	67.5	106.5	150	187.5	210	240	300	375	450
(Δp=280bar) Max. power	in 1000 r/min	P max	kw	5	8	14	22	35	50	63	70	80	100	125	150
	in 1500 r/min			7.5	12	21	33	53	75	95	105	120	150	188	225
(Δp=280bar) Max. torque		Tmax	Nm	45	71	125	200	316	445	557	624	713	890	1115	1337
Displacement		V g	ml/r	90	100	107	125	140	160	180	200	225	250	280	300
Weight		n max	rpm	2600	2600	2600	2600	1800	1800	1800	1800	1800	1800	1800	1800
Max. flow	In 1000 r/min	q v	L/min	90	100	107	125	140	160	180	200	225	250	280	300
	In 1500 r/min			135	150	160.5	187.5	210	240	270	300	337.5	375	420	450
(Δp=280bar) Max. power	In 1000 r/min	P max	kw	47.3	52.5	56.2	65.6	73.5	84	94.5	105	118	131	147	157.5
	In 1500 r/min			70.9	78.8	84.3	98.4	110.3	126	141.8	157.5	177.2	196.9	220.5	236.3
(Δp=280bar) Max. torque		Tmax	Nm	451	501	536	626	701	802	902	1003	1128	1253	1403	1504

Mounting Dimension

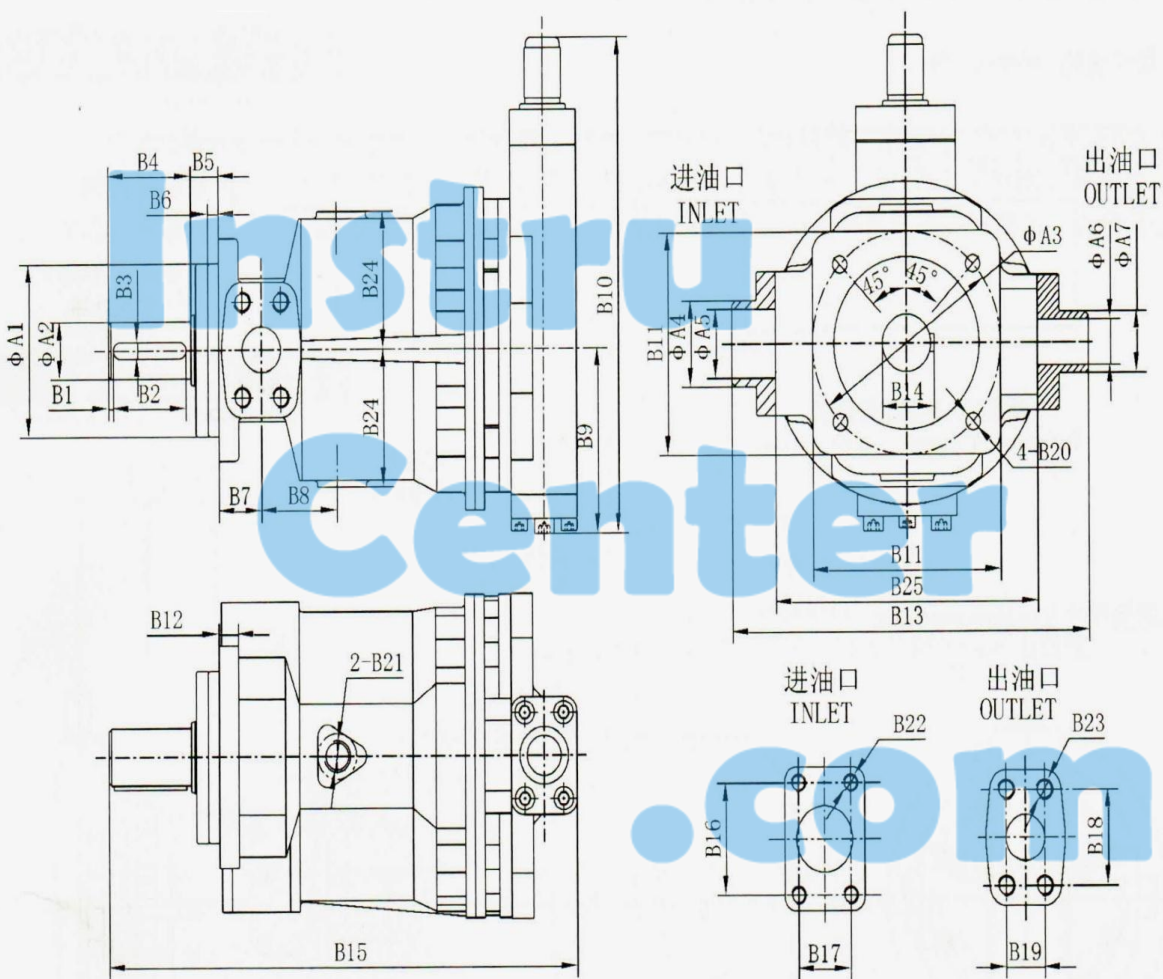

公称规格 Nominal size	A1	A2	A3	A4	A5	A6	A7	B1	B2	B3	B4	B5	B6	B7	B8	B9
10/16/18	75f9	25h6	100	35	25	15	25	4	30	8	39	18	9	25	33	102.4
25/28/32/40/45	100f9	30h6	125	42	34	20	28	4	45	8	52	21	9	30	48	108.2
55/63/71/80/90	120f9	40h6	155	50	40	25	35	4	50	12	60	21	9	35	57	129.5
95/100/107/125	120f9	40h6	155	60	50	32	43	4	60	12	68	23	9	35	62	131
140/160/180/200/225	150f9	55h6	198	76	66	38	52	4	100	16	105	25	9	44	74	146
250/280/300/320	180f9	60h6	230	100	90	50	65	5	100	18	110	23	9	75	95	168.5

公称规格 Nominal size	B10	B11	B12	B13	B14	B15	B16	B17	B18	B19	B20	B21	B22	B23	B24	B25
10/16/18	295	100	11	210	28	237.5	52.4	26.2	40.5	18.3	Φ 12	M14 × 1.5	M10 深 16	M8 深 15	60	146
25/28/32/40/45	295	125	15	236	33	303	58.7	30.2	50.8	23.8	Φ 12	M14 × 1.5	M10 深 18	M10 深 20	71	168
55/63/71/80/90	346	155	16	271	42.8	350	70	35.7	57.1	27.8	Φ 14	M18 × 1.5	M12 深 20	M12 深 24	88	200
95/100/107/125	346	155	16	294	42.8	385.5	77.8	42.9	66.7	31.6	Φ 14	M22 × 1.5	M12 深 20	M14 深 24	96	216
140/160/180/200/225	359	200	20	329	59	458.5	89	50.8	79.4	36.7	Φ 18	M22 × 1.5	M12 深 20	M16 深 25	112.5	249
250/280/300/320	383	230	28	392	63.9	541.5	120.7	62	96.8	44.5	Φ 24	M33 × 2	M16 深 27	M20 深 35	135	295

**Rexport****HY Piston Pump****DESIGN FEATURE:**

- 1, Swash plate design axial variable piston pump used in open circuit.
- 2, Continuous work pressure can reach 315bar, The highest instantaneous work pressure can reach 400bar.
- 3, The flow is directly proportional to the drive rotate speed and the displacement, and can make stepless variable come true by adjusting the obliquity of the swash plate.
- 4, Multiplicate energy saving of control ways eg. Constant pressure, Constant power etc. and the control response is very fast.
- 5, Low noises level, High efficiency, High reliability and timeproof.
- 6, Small volume, High power density.
- 7, Excellent oil absorbency.
- 8, Can supply standard SAE flange.

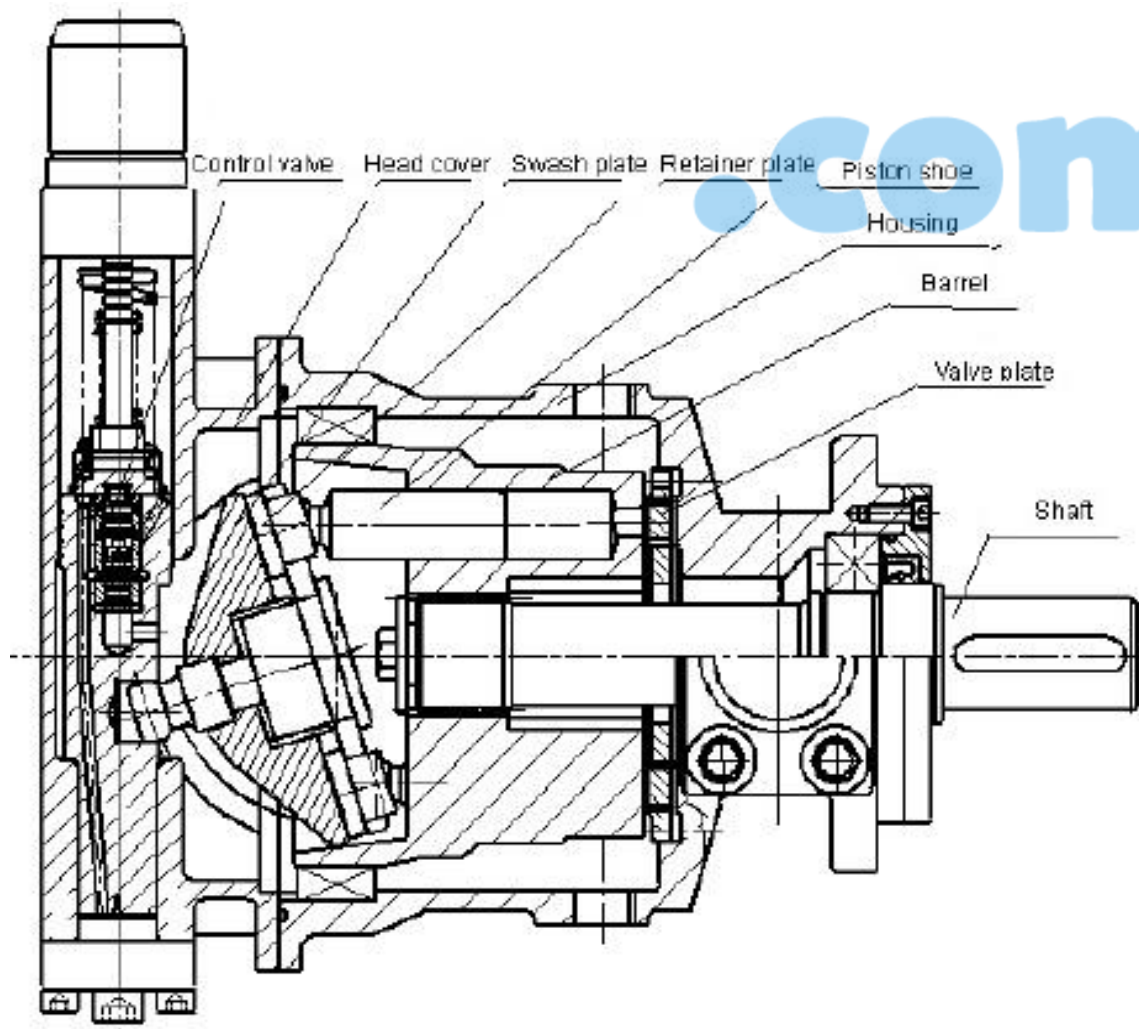

## 四、Installation Notes

Optional installation position. The displacement over 160L/min can't be installed on the reservoir and should ensure the reservoir cover have enough rigidity. The concentricity (verticality)  $\leq 0.05\text{mm}$ . The pump housing must be filled with fluid during commissioning and remain full when operating. In order to attain the lowest noise level, all connections (suction, pressure, case drain ports) must be linked by flexible couplings to tank. Avoid placing a check valve in the case drain line.

### 1. Vertical installation (shaft end upwards)

The following installation conditions must be taken into account:

#### 1.1. Arrangement in the reservoir

Before installation fill pump housing, keeping it in a horizontal position.

a) If the minimum fluid level is equal to or above the pump mounting

face close port "outlet 2" plugged, leave port "outlet 2" and "inlet" open, "outlet 2" piped and recommendation inlet piped (see Fig.1).

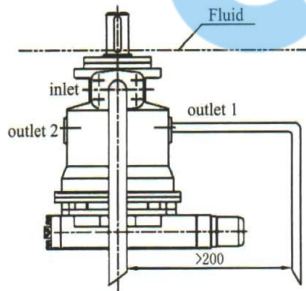

Fig. 1

b) If the minimum fluid level is below the pump mounting face pipe port "outlet 1" and "inlet" according to Fig 2

Close port "outlet 2" with respect taking into consideration. Conditions in 1.2.1.

#### 1.2. Arrangement outside the reservoir

Before installation fill the pump housing, keeping it in a horizontal position. For mounting above reservoir see Fig. 2.

Limiting condition:

1.2.1. Minimum pump inlet pressure  $p_{abs\ min} = 0.8\text{bar}$  under both static and dynamic conditions.

Note: Avoid mounting above reservoir wherever possible in order to achieve a low noise level.

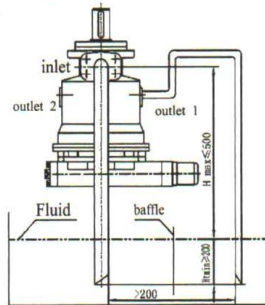

Fig.2

1.2.2 The permissible suction height  $h$  comes from the overall pressure loss, but may not be bigger than  $h_{\max} = 500\text{ mm}$  (immersion depth  $h_{\min} = 200\text{ mm}$ ).

### 2. Horizontal installation

The pump must be installed, so that "outlet 1" is at the top.

#### 2.1. Arrangement in the reservoir

a) If the minimum fluid level is above the top of the pump, port "outlet 2" closed, "outlet 1" and "inlet" should remain open, "outlet 1" piped and recommendation "inlet" piped (see Fig. 3)

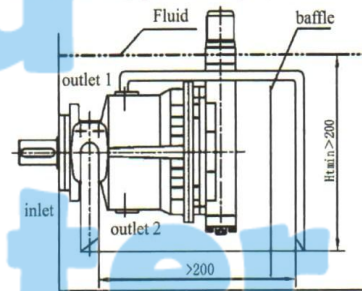

Fig. 3

b) If the minimum fluid level is equal to or below the top of the pump, pipe ports "outlet 1" and possibly "inlet" as Fig. 4.; close port "outlet 2".

The conditions according to item 1.2.1.

#### 2.2. Installation outside the reservoir

Fill the pump housing before commissioning. Close the port "outlet 1"

a) When mounting above the reservoir, see Fig. 4.

Conditions according to 1.2.1.

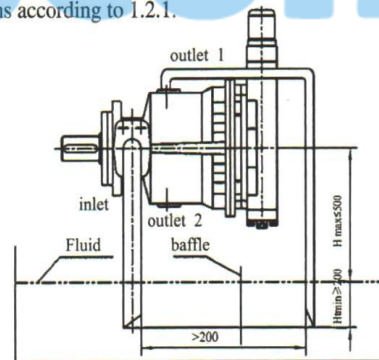

Fig. 4

b) Mounting below the reservoir Pipe ports "outlet 1" and "inlet" according to Fig.5, close port "outlet 2"

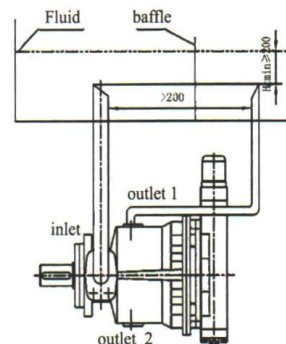

Fig.5