

Rexport**Pilot operated pressure reducing valve,
type DR... 30B/**

RE 26891/12.2004

Size 10, 20, 30

up to 31.5MPa

up to 320L/min

Replaces:
RE26891/05.2001**Features:**

- For subplate mounting
- For threaded connections
- For cartridge connection
- 4 adjustment elements:
 - Rotary knob,
 - Sleeve with hexagon and protective cap,
 - Lockable rotary knob with scale,
 - Rotary knob with scale
- 4 pressure settings
- Optional check valve (only for valve for subplate mounting)
- Mounting pattern to DIN 24 340, form D, ISO 5781 and CETOP-RP 121H

**Functional, section**

Pressure valves type DR are pilot operated pressure reducing valves, which are controlled from the secondary circuit.

They basically consist of main valve (1) with main spool insert (3) and pilot valve (2) with pressure adjustment element (9).

At rest, the valves are open, fluid can freely pass from port B to port A via the main spool (3).

Pressure present in port A acts upon the bottom side of the main spool (3). At the same time there is pressure acting on the poppet (6) in the pilot valve (2) via the orifice (4) on the spring-loaded side of the main piston (3) and via the port (5). Same it is acting on the poppet (6) via the orifice (7), control line (8), and orifice (10). According to setting of spring (11), pressure builds up in front of the poppet (6), in port (5) and in spring chamber (12), holding the control spool (3) in the open position. Fluid can freely flow from port B to port A via main spool (3), until the pressure in port A exceeds the value set at spring (11) and opens the poppet (6). The control piston (3) moves to closing position. The desired reduced pressure is achieved, when a balance between the pressure in port A and the pressure set at spring (11) is reached.

Pilot oil drain from spring chamber (12) to tank takes place externally via line (15).

Free return flow from port A to B can be achieved by installing an optional check valve (14).

A pressure gauge connection (17) allows the reduced pressure in port A to be monitored.

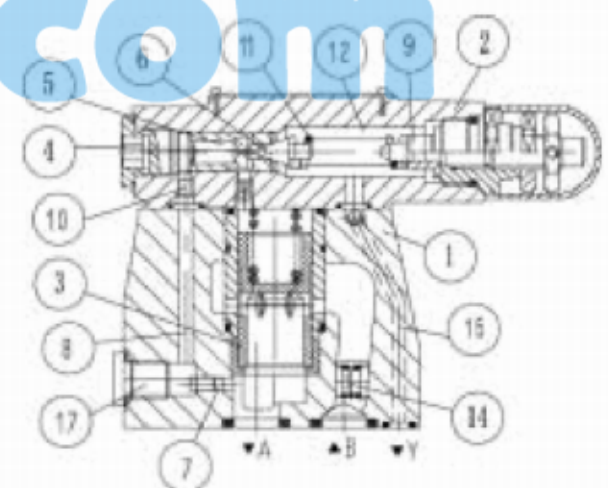

DR10-5-30B/...Y...

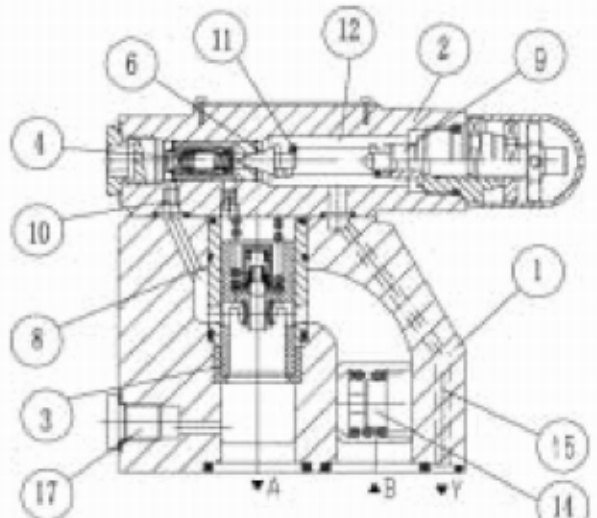

Type DR20, 30-5-30B/...Y...

Characteristic Curves (measured at $v = 41 \text{ mm}^2/\text{s}$ and $t = 50 \text{ }^\circ\text{C}$)

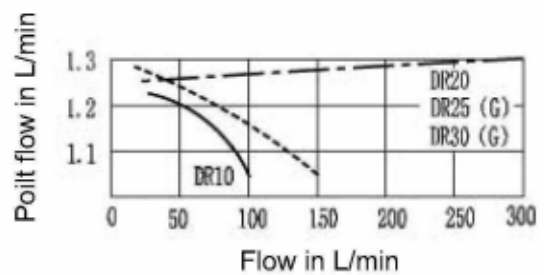
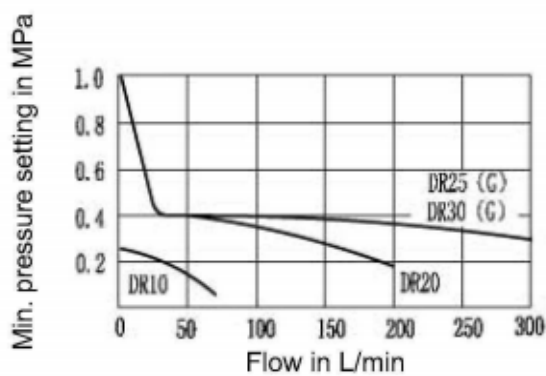
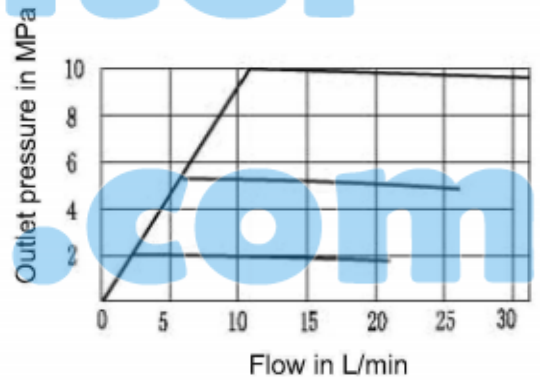
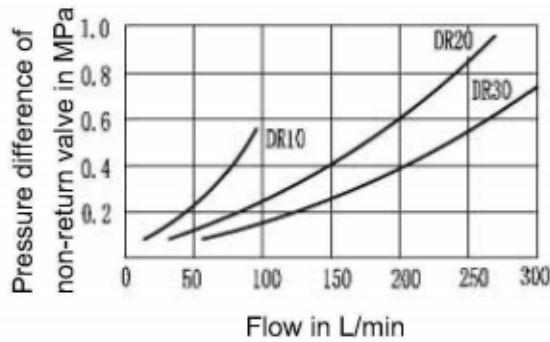
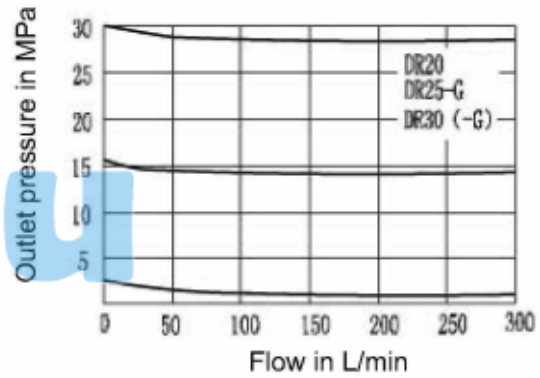
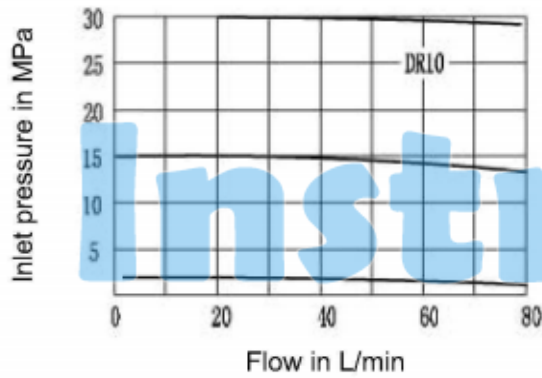

- = 2MPa Δ PDR10
- = 10MPa Δ PDR10
- = 2MPa and 10MP Δ P DR20 and DR30

Unit Dimensions: Valve for subplate mounting

(Dimensions in mm)

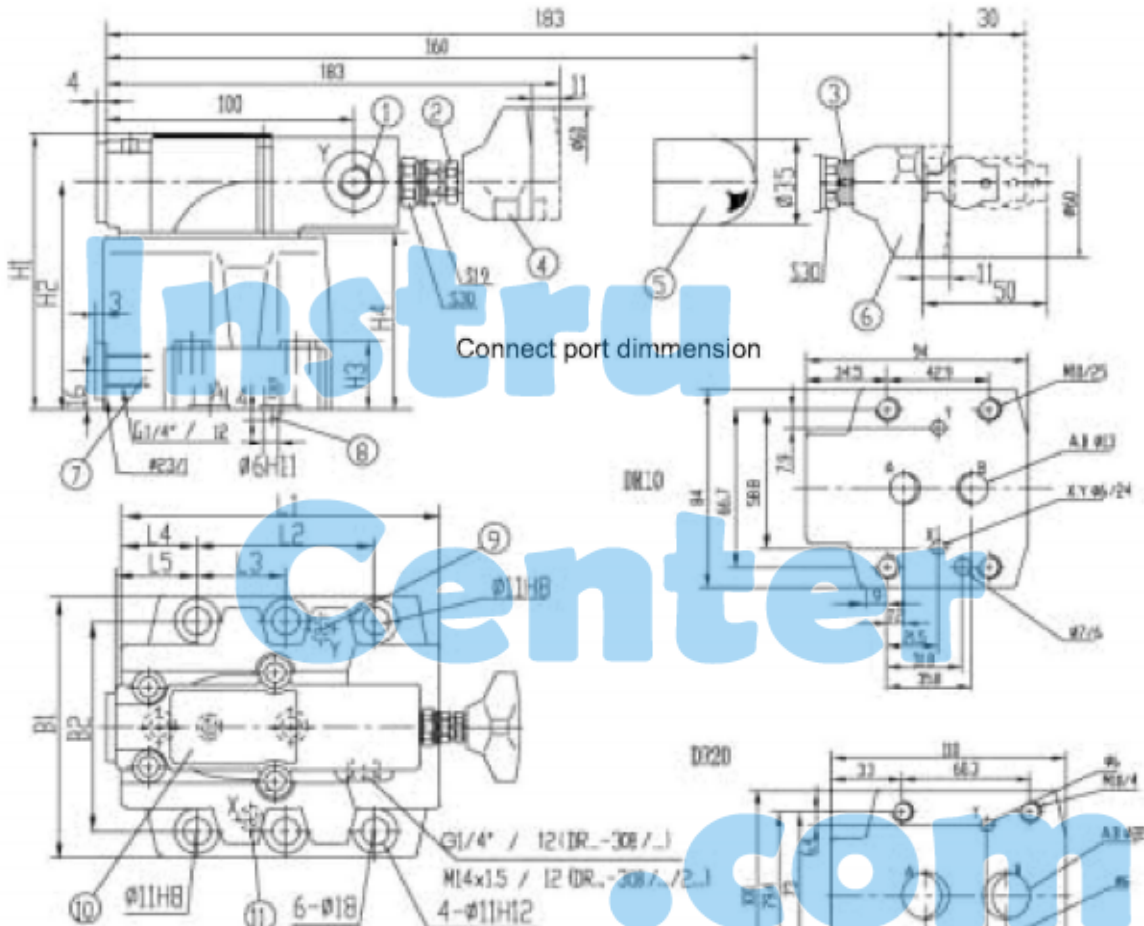

- 1 Port Y optional
- 2 Only for 31.5MPa
- 3 Repeat adjustment scale
- 4 Adjustment element 1
- Adjustment element 2
- Adjustment element 3
- 7 Pressure gauge connection
- 8 Locating pin
- 9 Port Y for external pilot oil drain
- 10 Nameplate
- 11 Port X without function (blind bore)

Subplates for :see page 150

G460/01 G460/02 G412/01 G412/02 G414/01 G414/02
 G461/01 G461/02 G413/01 G413/02 G415/01 G415/02

Size	Fixing screw (GB/T70.1-2000)
10	4-M10x50-10.9
20	4-M10x60-10.9
30	4-M10x70-10.9

Size	B1	B2	H1	H2	H3	H4	L1	L2	L3	L4	L5	O-ring	
												for ports X, Y	for ports A, B
10	85	66.7	112	92	28	72	90	42.9	-	35.5	34.5	9.25 × 1.78	17.12 × 2.62
20	102	79.4	122	102	38	82	112	60.3	-	33.5	37	9.25 × 1.78	28.17 × 3.53
30	120	96.8	130	110	46	90	140	84.2	42.1	28	31.3	9.25 × 1.78	34.52 × 3.53

Unit Dimensions: insert mounting

(Dimensions in mm)

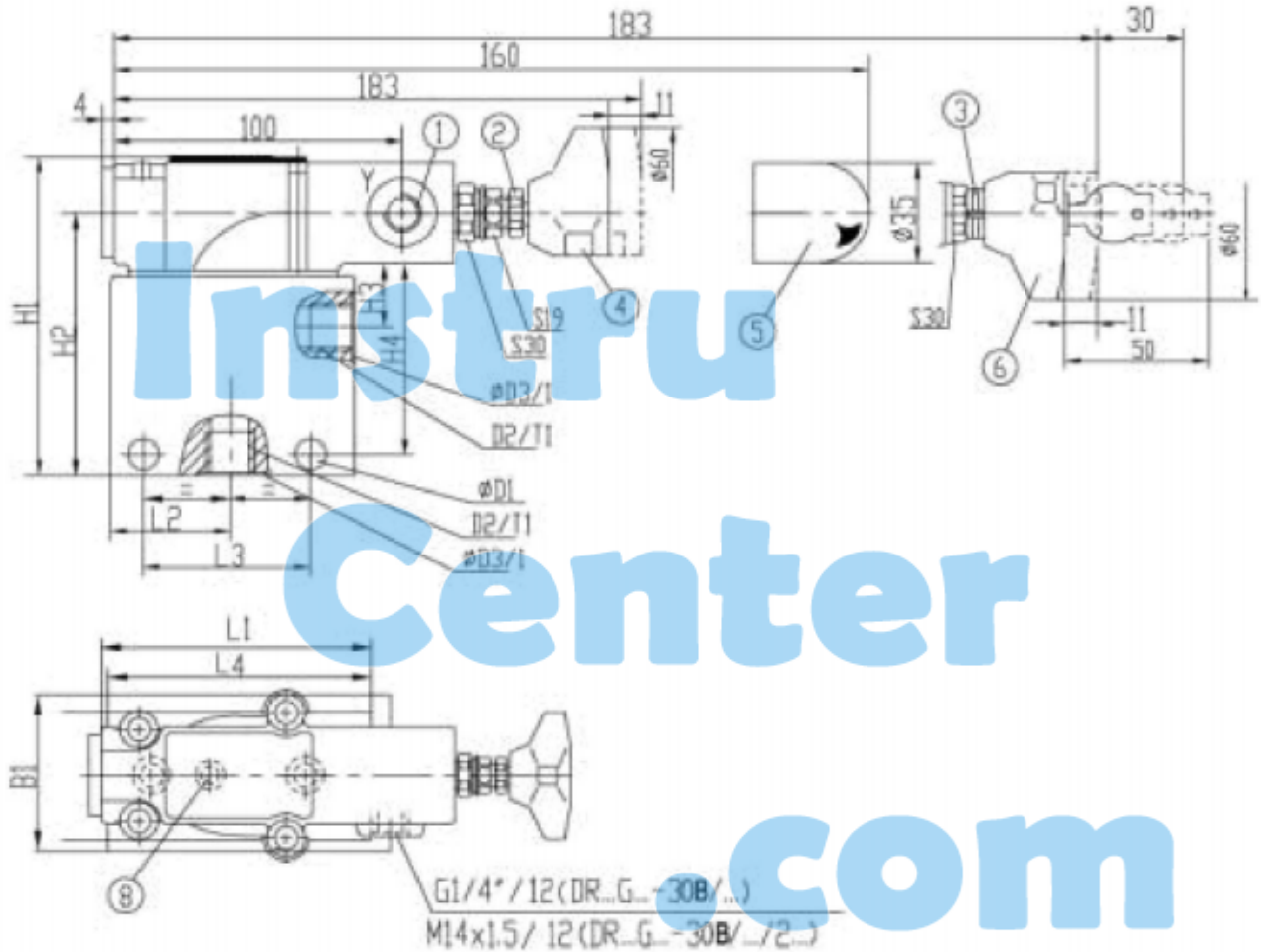

- 1. Port Y optional
- 2. Only for 31.5MPa
- 3. Repeat adjustment scale
- 4. Adjustment element 1
- 5. Adjustment element 2
- 6. Adjustment element 3
- 7. Pressure gauge connection port

Warning: pipe mounting without non-return valve, can not flow reverse

Size	B1	φ D1	D2		φ D3	H1	H2	H3	H4	L1	L2	L3	L4	T1	Weight (kg)
			Metric	British											
10	63	9	M22 × 1.5	G1/2"	34	125	105	28	75	90	40	62	85	14	4.3
15			M27 × 2	G3/4"	42									16	
20			M33 × 2	G1"	47									18	
25	70	11	M42 × 2	G1 1/4"	58	138	118	34	85	100	46	72	99	20	10.2
30			M48 × 2	G1 1/2"	65									22	

Unit Dimensions:insert mounting

(Dimensions in mm)

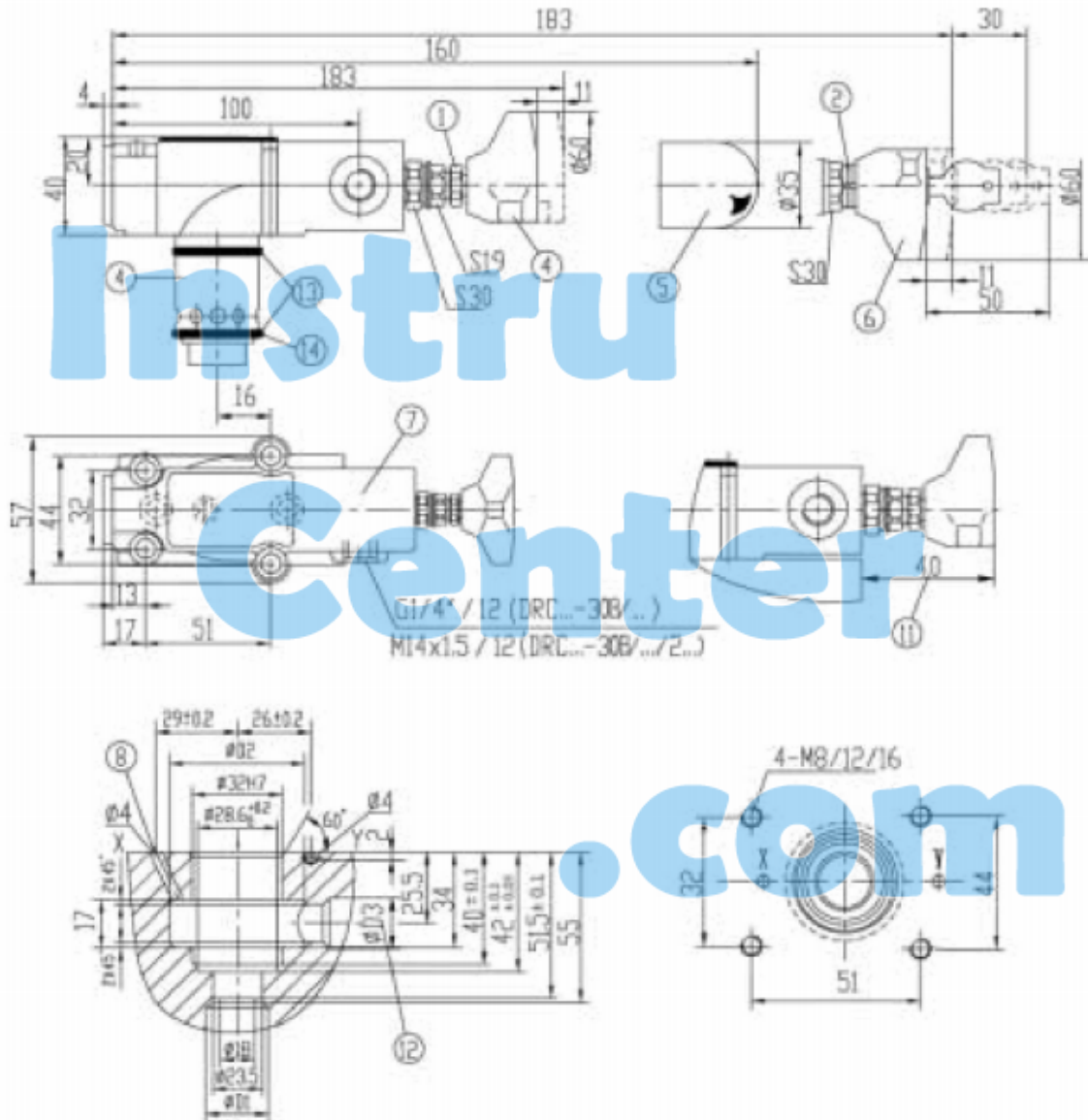

1. Only for 31.5MPa
2. Repeat adjustment scale
3. Main spool assembly
4. Adjustment element 1
5. Adjustment element 2
6. Adjustment element 3
7. Nameplate
8. Pilot control oil supply
11. Min. distance when adjustment element "1" or "3" insert integration block
12. Hole D3 can meet hole D2 at any location, but can't meet port 'X' and fixed screw.
- 13 O-ring 27.3X2.4
- 14 Retainer ring 32X28.4X0.8

Size	φ D1	φ D2	φ D3	locating screw (GBT70.1-2000)	Weight (kg)
10	10	40	10	4-M8 × 40-10.9	1.4
20	25	40	25		
30	32	45	32		

Instru Center .com

NOTICE

1. The fluid must be filtered. Minimum filter fineness is 20 μm .
2. The tank must be sealing up and an air filter must be installed on air entrance.
3. Products without subplate when leaving factory, if need them, please ording specially.
4. Vavle fixing screws must be high intensity level (class 10.9). Please select and use them according to the parameter listed in the sample book.
5. Roughness of surface linked with the valve is required to $0.8 \sqrt{R}$.
6. Surface finish of mating piece is required to 0.01/100mm.