

Rexport

Pilot operated Check valve sandwich plate Type Z2S

RE 21600/12.2004

size 6, 10
16, 22

up to 31.5 MPa

up to 360L/min

Replace: 21547/05.2001
21551/05.2001
RE: 21556/05.2001
21560/05.2001

Features:

- For the leak free closure of one or two service ports
- Mounting pattern to DIN 24 340 form A, ISO 4401 and ETOP-RP 121H for use in vertical stacking assemblies



Functional, section

Hydraulic pilot operated check valves type Z2S are of sandwich plate design. They are used for the leak-free closure of one or two service ports, even for long periods of time. Free flow occurs from A1 to A2 or B1 to B2. Flow in the opposite direction is blocked.

In order to ensure correct closing of the valve, the service ports of the directional valve must be connected to tank in the neutral position.

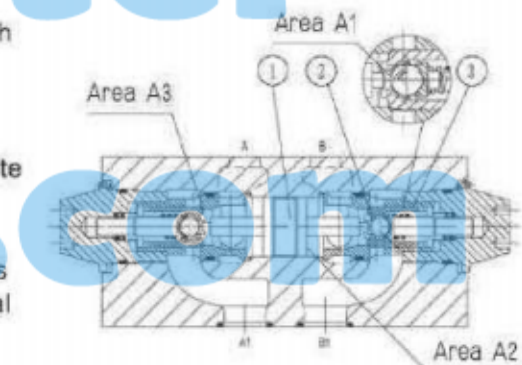

Ordering details

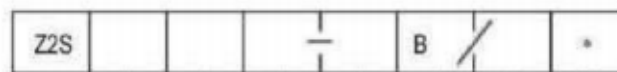

Size 6	= 6
Size 10	= 10
Size 16	= 16
Size 22	= 22

Further details in clear text

No code = Mineral oils
V = Phosphate ester

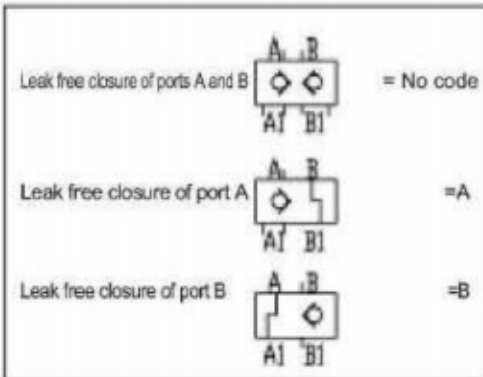

20 = Series 20 to 29 (Apply to size 10)
(20 to 29: unchanged installation and connection dimensions)
30 = Series 30 to 39 (Apply to size 16, 22)
(30 to 39: unchanged installation and connection dimensions)
40 = Series 40 to 49 (Apply to size 6)
(40 to 49: unchanged installation and connection dimensions)

(only for size 10)
1= Cracking pressure 0.15 MPa
2= Cracking pressure 0.3 MPa
3= Cracking pressure 0.6 MPa

Typical circuit example

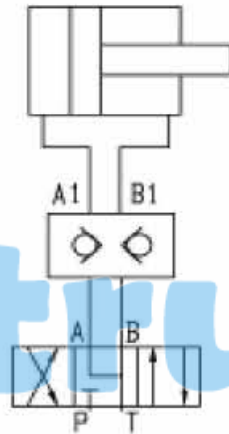

Symbols

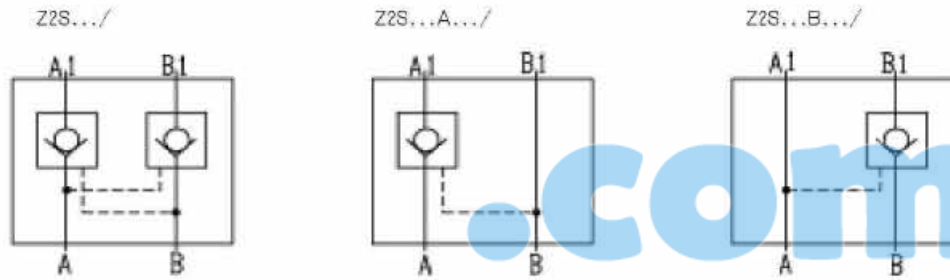

Technical data

Size	6	10	16	22		
Max. flow L/min (L/min)	to 60	to 120	to 200	to 360		
Max. operating pressure (MPa)	31.5					
Cracking pressure (MPa)	0.15	0.15	0.3	0.6	0.25	0.25
Directions	Flow freely via check valve from A to A1 or B to B1 pilot operated from B1 to B or A1 to A					
Area ratio	A1/A2=1:3	A1/A2=1:2.86 A3/A2=1:11.45	A1/A2=1:11.8 A3/A2=1:2.8	A1/A2=1:13.6 A3/A2=1:2.8		
Pressure fluid	Mineral oils(for NBR seal) or phosphate ester(for FPM seal)					
Pressure fluid temperature range (°C)	-20 to +80					
Viscosity range (mm²/s)	2.8 to 500					
Weight (kg)	0.8	2	7	11.7		

Characteristic curves (measured at $v = 41 \text{ mm}^2/\text{s}$ and $t = 50^\circ\text{C}$)

Type Z2S6

— = A → A1; B → B1
 - - - = A1 → A; B1 → B

1. Normal cracking
2. Check valve cartridge
3. Flow freely (without check valve)
4. Through check valve cartridge
5. Flow freely (without check valve cartridge Type "A" and type "B")

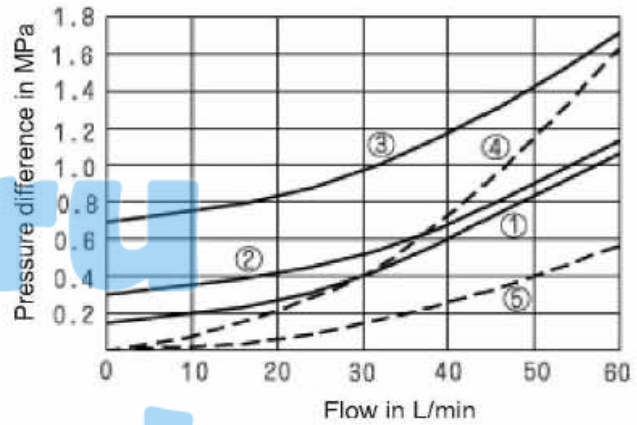

Type Z2S10

— = A → A1; B → B1
 - - - = A1 → A; B1 → B

1. Cracking pressure 1 = 0.15MPa
2. Cracking pressure 2 = 0.3MPa
3. Cracking pressure 3 = 0.6MPa

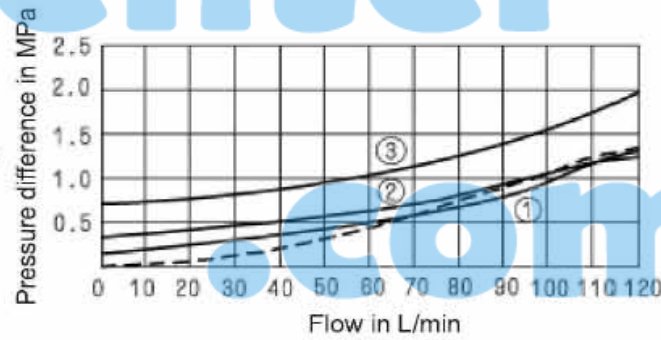

Type Z2S16

— = A → A1; B → B1
 - - - = A1 → A; B1 → B

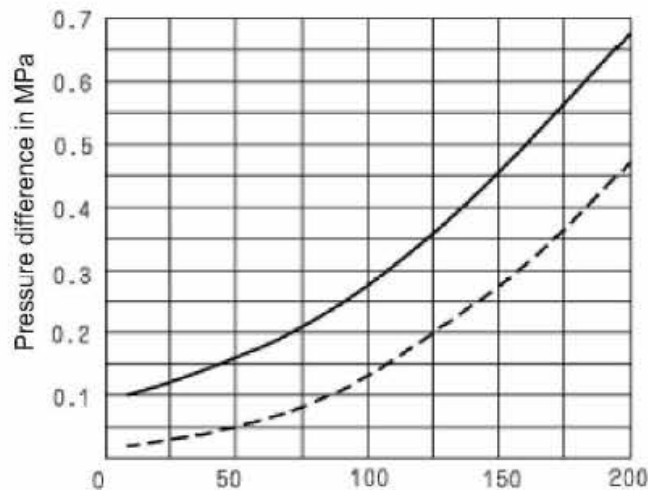

Type Z2S 22

— = A → A1; B → B1
 - - - = A1 → A; B1 → B

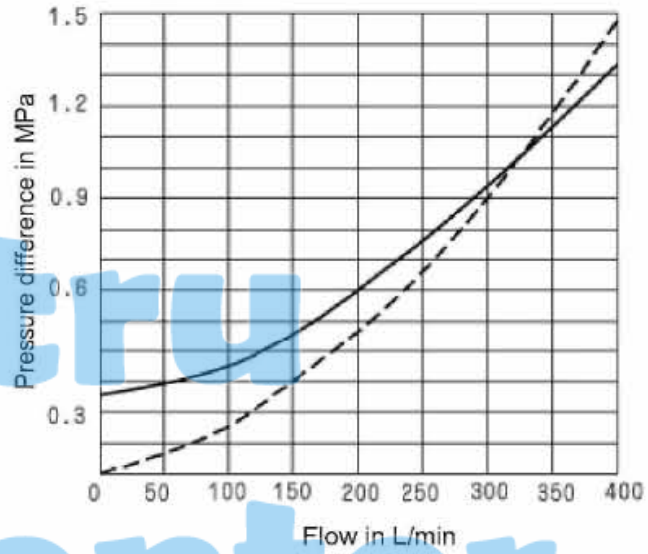

Unit dimensions : (Size6)

(Dimensions in mm)

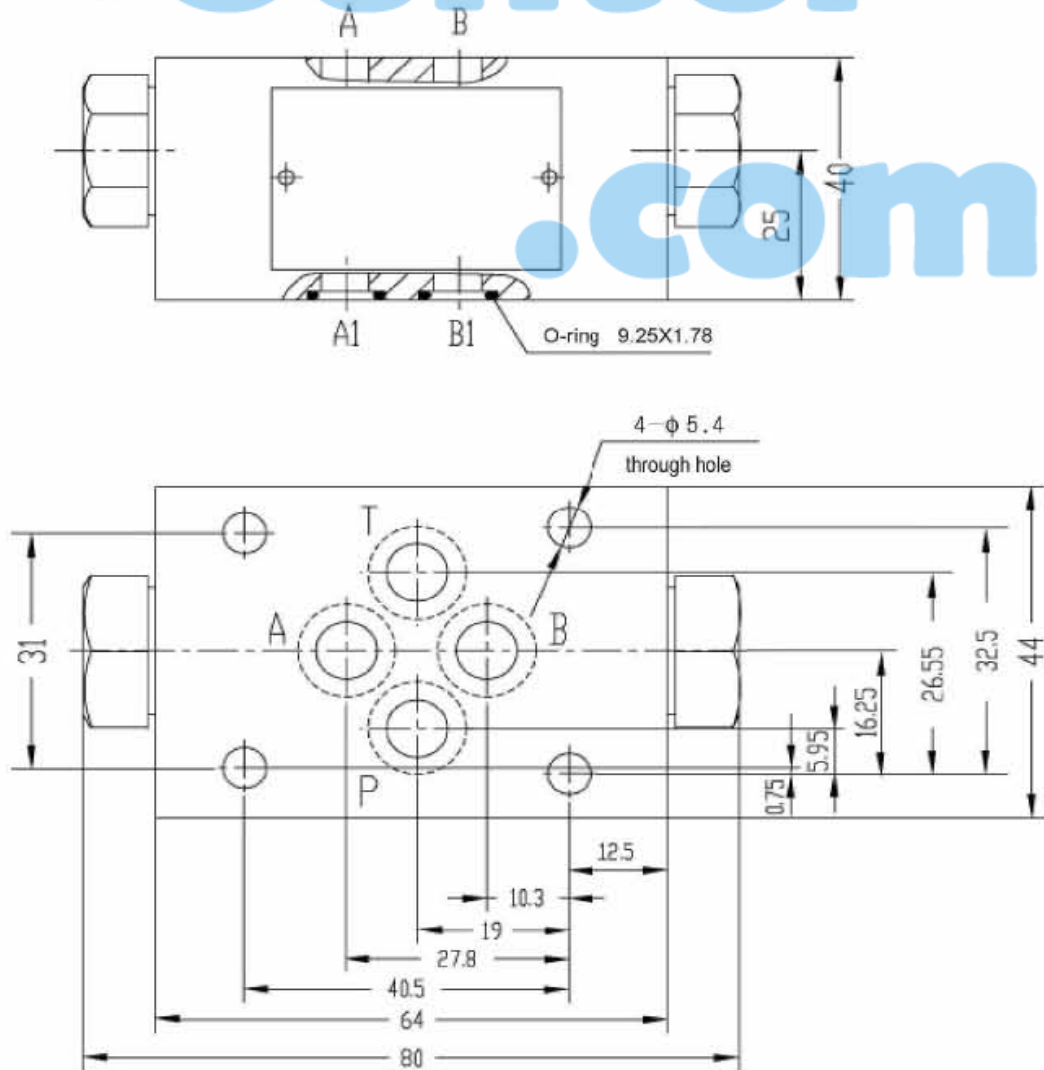

Unit dimensions: (Size10)

(Dimensions in mm)

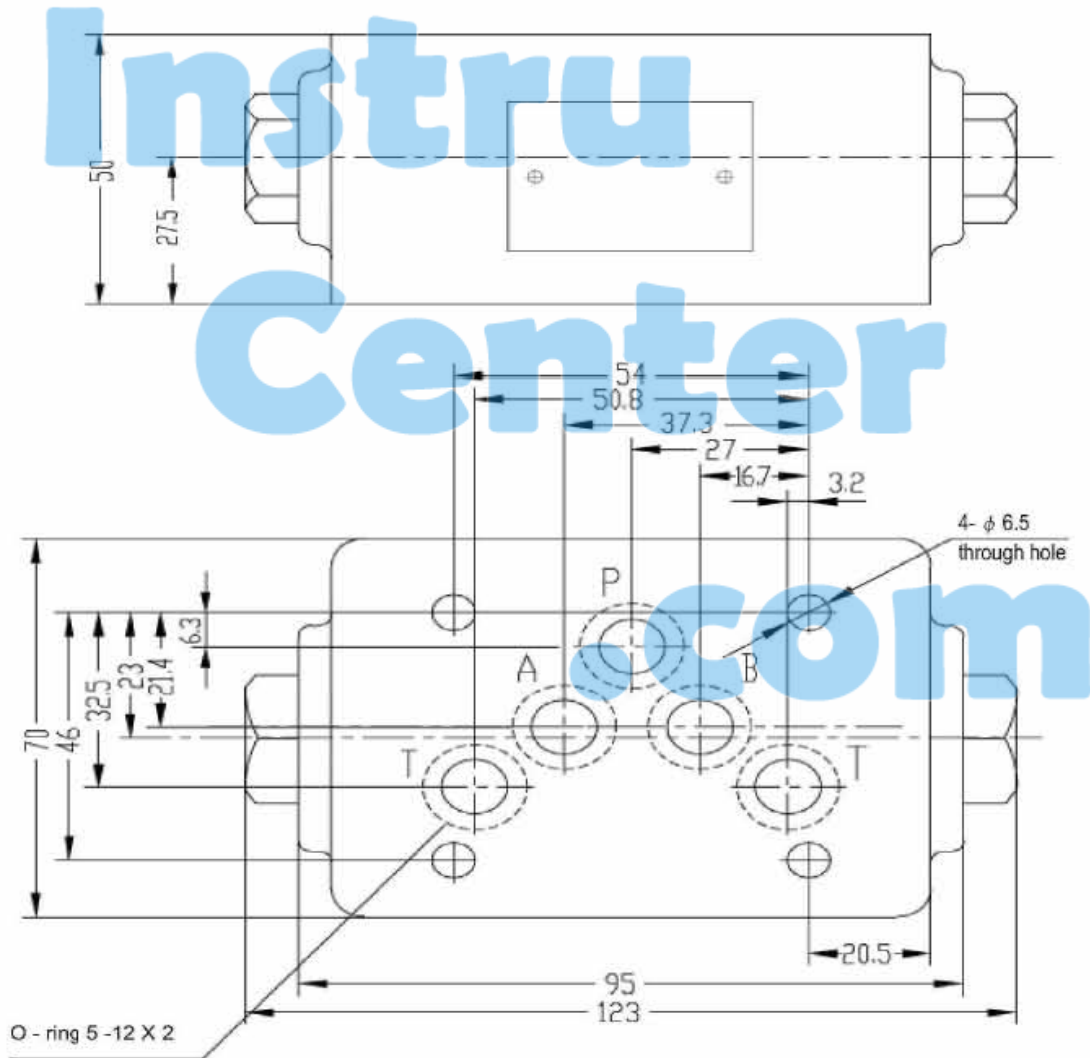

Unit dimensions

(Dimensions in mm)

Size16

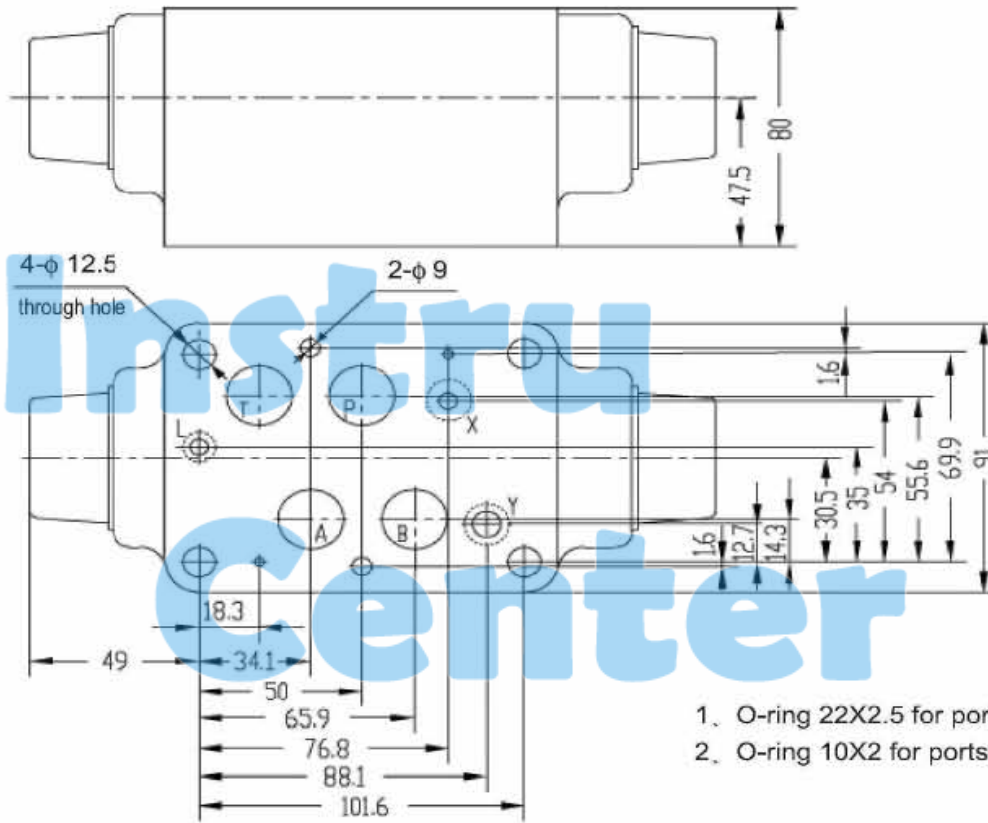

1. O-ring 22X2.5 for ports P, A, B, T
2. O-ring 10X2 for ports X, Y, L

Size22

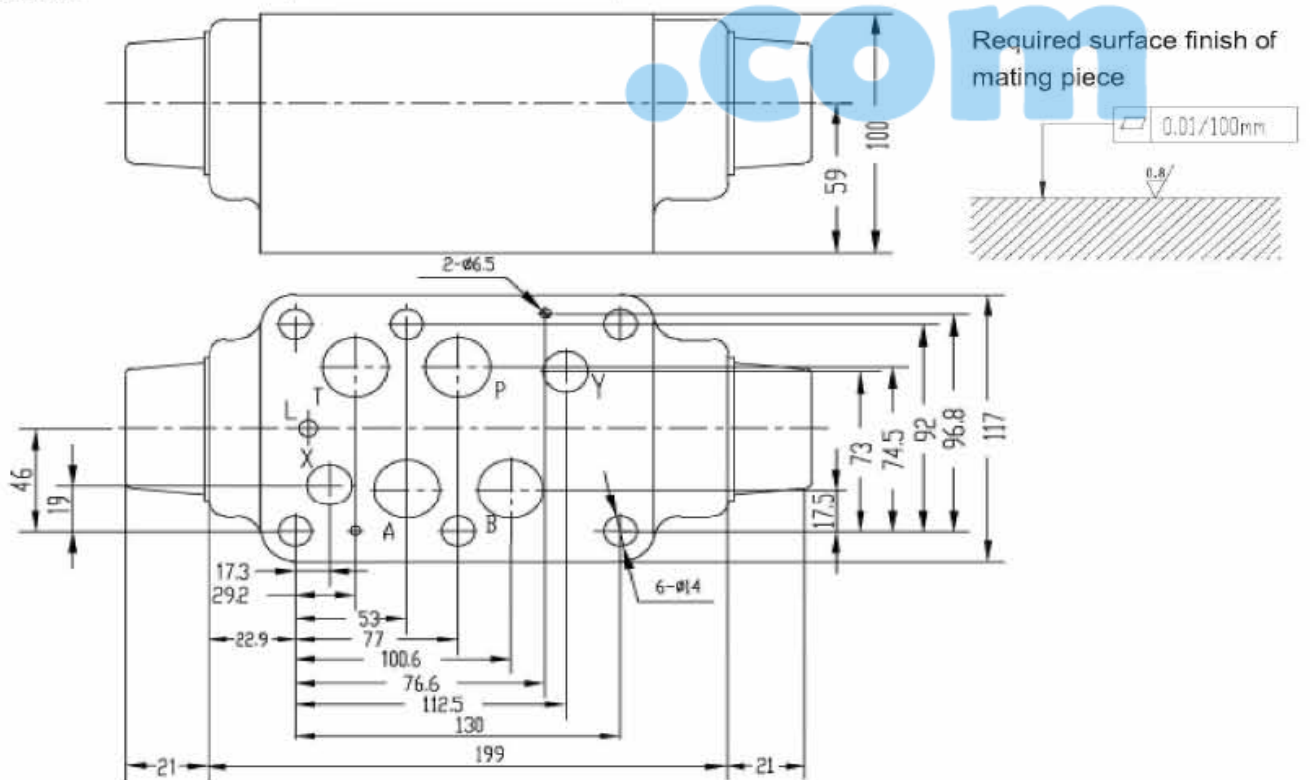

1. O-ring 27X3 for ports P, A, B, T
2. O-ring 19X3 for ports X, Y, L

<h1>Rexport</h1>	Pilot operated Check valve sandwich plate Type Z2S (New Series)			RE 21601/12.2004
	Size 6, 10 16, 22	up to 31.5 MPa	up to 450L/min	

Features:

- For use in vertical stacking assemblies
- For the leak free closure of one or two service ports
- Porting pattern to Din 24 340 form A, ISO 4401 and CETOP-RP 121H



InstruCenter.com

Functional, section

Hydraulic pilot operated check valves type Z2S are of sandwich plate design.

They are used for the leak-free closure of one or two service ports, even for long periods.

Free flow occurs from A1 to A2 or B1 to B2. In the opposite direction, the flow is blocked.

When fluid flows from A1 to A2, the pressure is pushed to the right, opening the ball poppet valve (2) and the poppet (3).

In order to ensure correct closing of service ports of the directional valve, the valve is connected to tank in the neutral position.

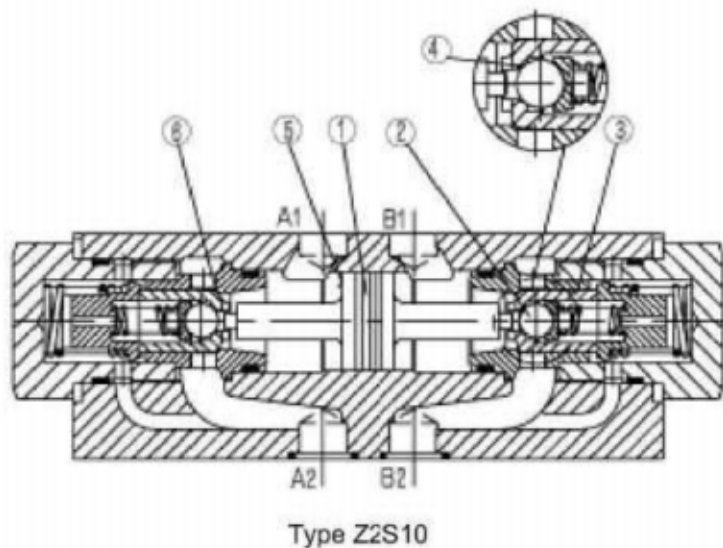
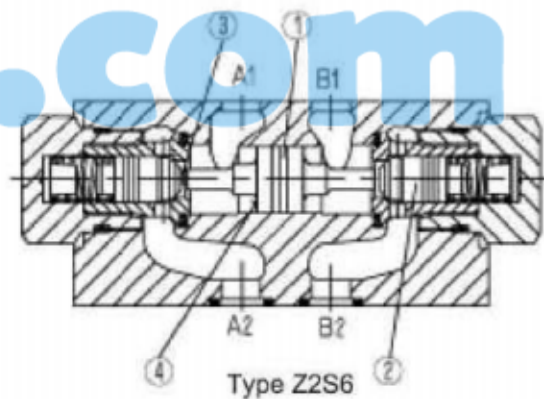

- 1 Spool
- 2 Ball poppet valve
- 3 Poppet
- 4 Area A1
- 5 Area A2
- 6 Area A3

Typical circuit example

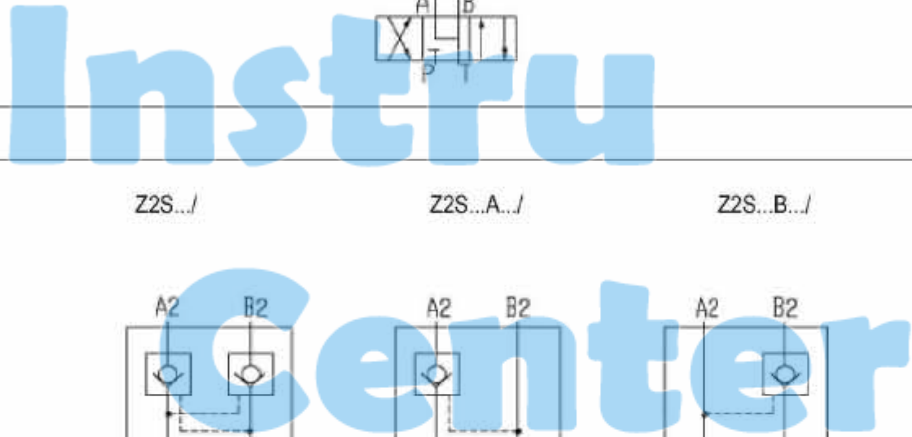
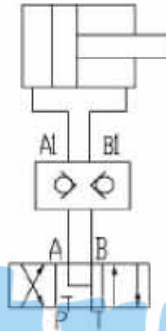

Symbols

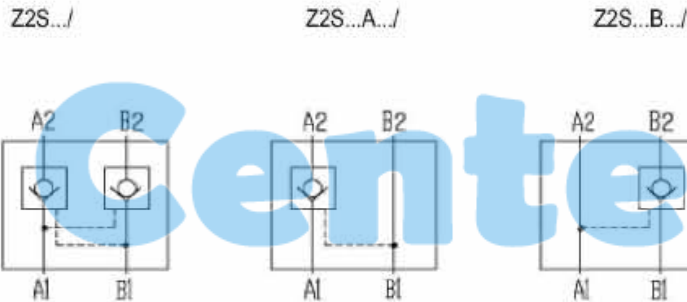

Ordering details

<p>Z2S</p>		<p>B / *</p>	
<p>Size6 = 6</p> <p>Size10 = 10</p> <p>Size16 = 16</p> <p>Size22 = 22</p>		<p>Further details in clear text</p> <p>No code = Mineral oils</p> <p>V = Phosphate ester</p>	
<p>Leak free closure of ports A and B</p> <p>= No code</p> <p>Leak free closure of port A</p> <p>= A</p> <p>Leak free closure of port B</p> <p>= B</p>		<p>30 = Series 30 to 39 (Apply to size 10) (30 to 39: unchanged installation and connection dimensions)</p> <p>50 = Series 50 to 59 (Apply to size 16,22) (50 to 59: unchanged installation and connection dimensions)</p> <p>60 = Series 60 to 69 (Apply to size 6) (60 to 69: unchanged installation and connection dimensions)</p>	
		<p>1 = Cracking pressure 0.15MPa (only for size6, 10)</p> <p>Cracking pressure 0.3MPa (only for size16, 22)</p> <p>2 = Cracking pressure 0.3MPa</p> <p>Cracking pressure 0.5MPa (only for size 16,22)</p> <p>3 = Cracking pressure 0.6MPa (only for size10)</p> <p>Cracking pressure 0.7MPa (only for 6)</p> <p>Cracking pressure 0.75MPa (only for 16, 22)</p> <p>4 = Cracking pressure 1.0MPa (only for 10, 16, 22)</p>	

Technical data

Size		6	10	16	22
Max. flow L/min	(L/min)	to 60	to 120	to 300	to 450
Max. operating pressure	(MPa)	31.5			
Cracking pressure	(MPa)	see curve			
Directions		see symbols			
Area ratio		A1/A2=1.3	A1/A2=1:11.45 A3/A2=12.86	A1/A2=1:11.8 A3/A2=12.8	A1/A2=1:13.6 A3/A2=12.8
Pressure fluid		Mineral oils(for NBR seal) or phosphate ester(for FPM seal)			
Pressure fluid temperature range	(°C)	-30 to +80			
Viscosity range	(mm ² /s)	2.8 to 500			
Weight	(kg)	approx. 0.8	approx. 3	approx. 6.5	approx. 12

Characteristic curves (measured at $\nu = 41 \text{ mm}^2/\text{s}$ and $t = 50 \text{ }^\circ\text{C}$)

Type Z2S6

— = A1 → A2, B1 → B2

- - - = A2 → A1, B2 → B1

1. Cracking pressure 1=0.15MPa
2. Cracking pressure 2=0.3MPa
3. Cracking pressure 3=0.7MPa
4. Through check valve cartridge
5. Flow freely

(Without check valve cartridge type "A" and type "B")

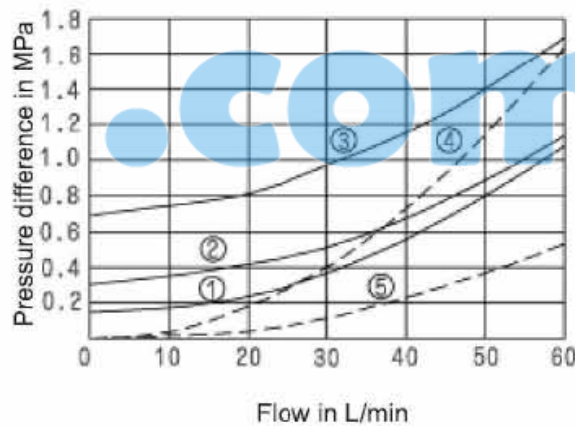

Type Z2S10

— = A1 → A2, B1 → B2

- - - = A2 → A1, B2 → B1

1. Cracking pressure 1=0.15MPa
2. Cracking pressure 2=0.3MPa
3. Cracking pressure 3=0.6MPa
4. Cracking pressure 4=1.0MPa

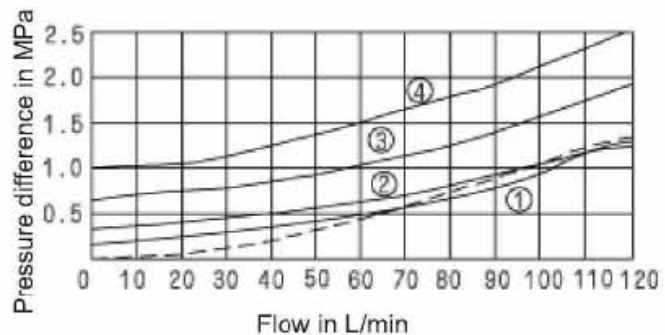

Type Z2S16

— = A1 → A2, B1 → B2
 - - - = A2 → A1, B2 → B1

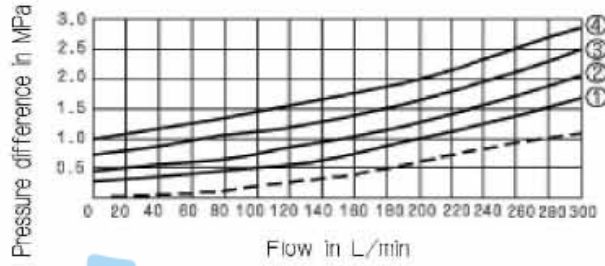

Type Z2S22

— = A1 → A2, B1 → B2
 - - - = A2 → A1, B2 → B1

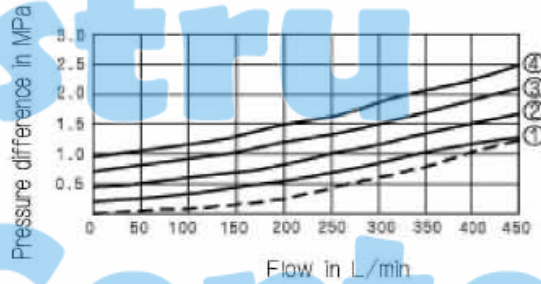

Unit dimensions

(Dimensions in mm)

Size6

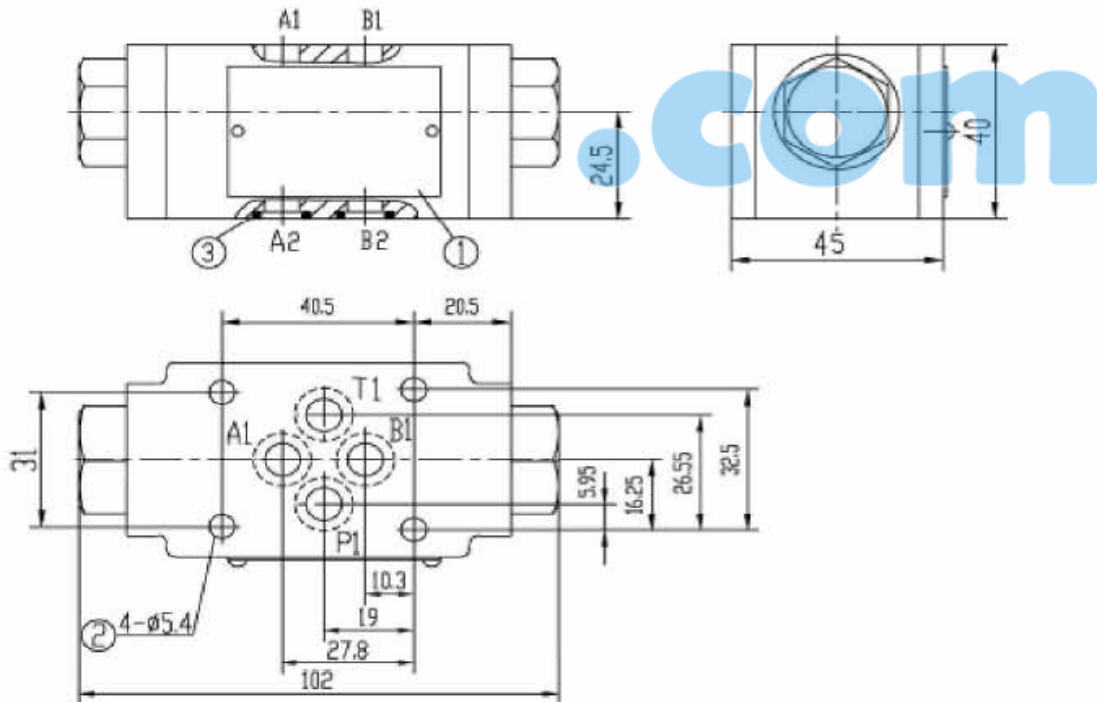

1. Name plate
2. Holes for mounting
3. O-rings 9.25 x 1.78 for four ports
 Valve fixing screws 4 - M5 -10.9
 (GB/T70.1-2000)
 Screw torque: $M_A = 8.9\text{Nm}$

Unit dimensions

(Dimensions in mm)

Size 10

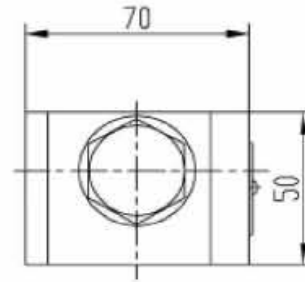
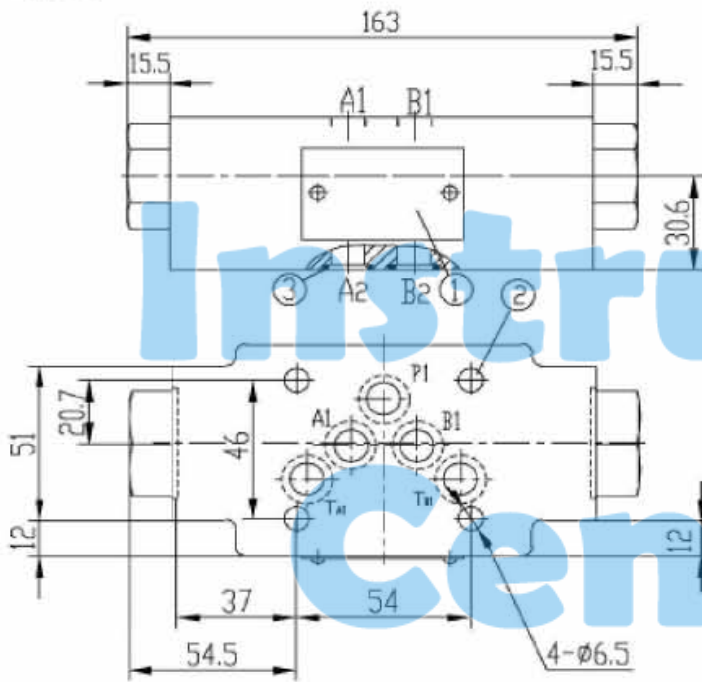

- 1. Nameplate
- 2. Holes for mounting
4 - ϕ 6.5
- 3. O-rings 12x 2 for 5 ports
P, A, B, T_{A1}, T_{B1}
Valve fixing screws
4-M6 -10.9
(GB/T70.1-2000)
Screw torque : $M_A=15.5\text{Nm}$

Size 16

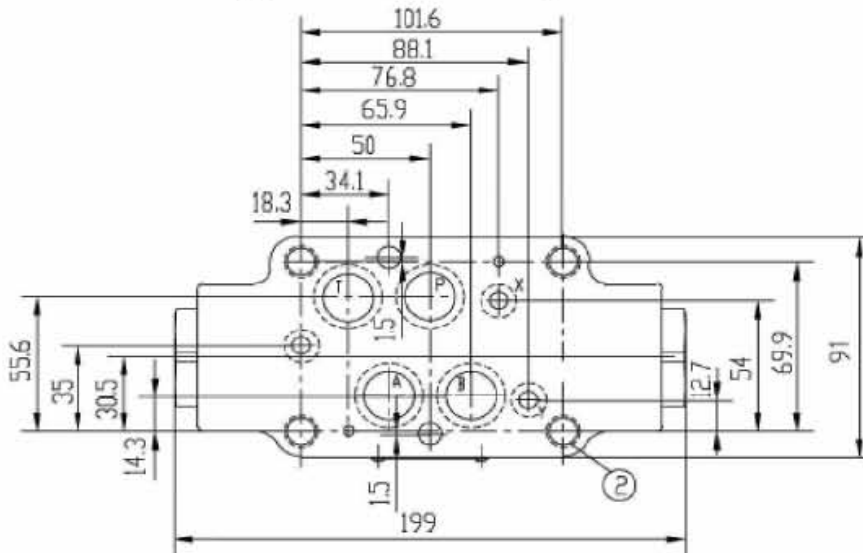
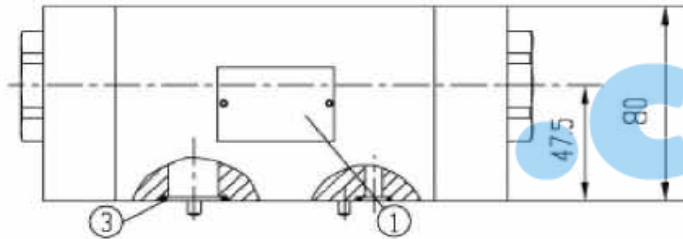

- 1. Nameplate
- 2. Holes for mounting
- 3. O-rings 22x 2.5 for ports
P, A, B, T
10X2 for ports X, Y, L
Valve fixing screws:
① 4-M10 -10.9
(GB/T70.1-2000)
Screw torque: $M_A=75\text{Nm}$
② 2-M6 -10.9
(GB/T70.1-2000)
Screw torque : $M_A=15.5\text{Nm}$

Size22

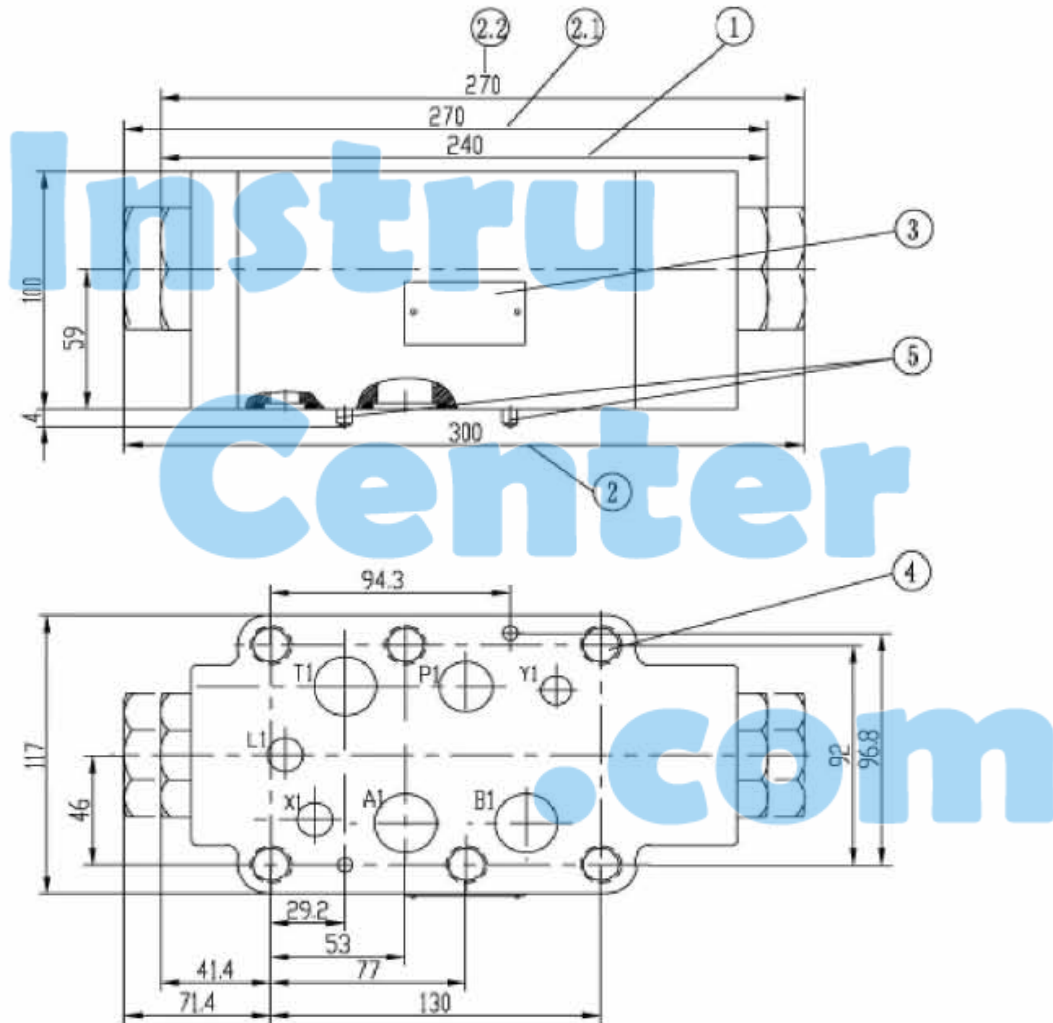

- 1 Cracking pressure 0.3MPa or 0.5MPa , Leak free closure of ports A and B
- 2 Cracking pressure 0.75MPa or 1.0MPa , Leak free closure of ports A and B
- 2.1 Cracking pressure 0.75MPa or 1.0MPa , Leak free closure of port A
- 2.2 Cracking pressure 0.75MPa or 1.0MPa , Leak free closure of port B
- 3 Label plate
- 4 Valve fixing screws:
 - 6- M14-10.9 (GB/T70.1-2000) ,
 - Screw torque: $M_A=205\text{Nm}$
- 5 Fixing pin

Required surface finish of mating piece

